

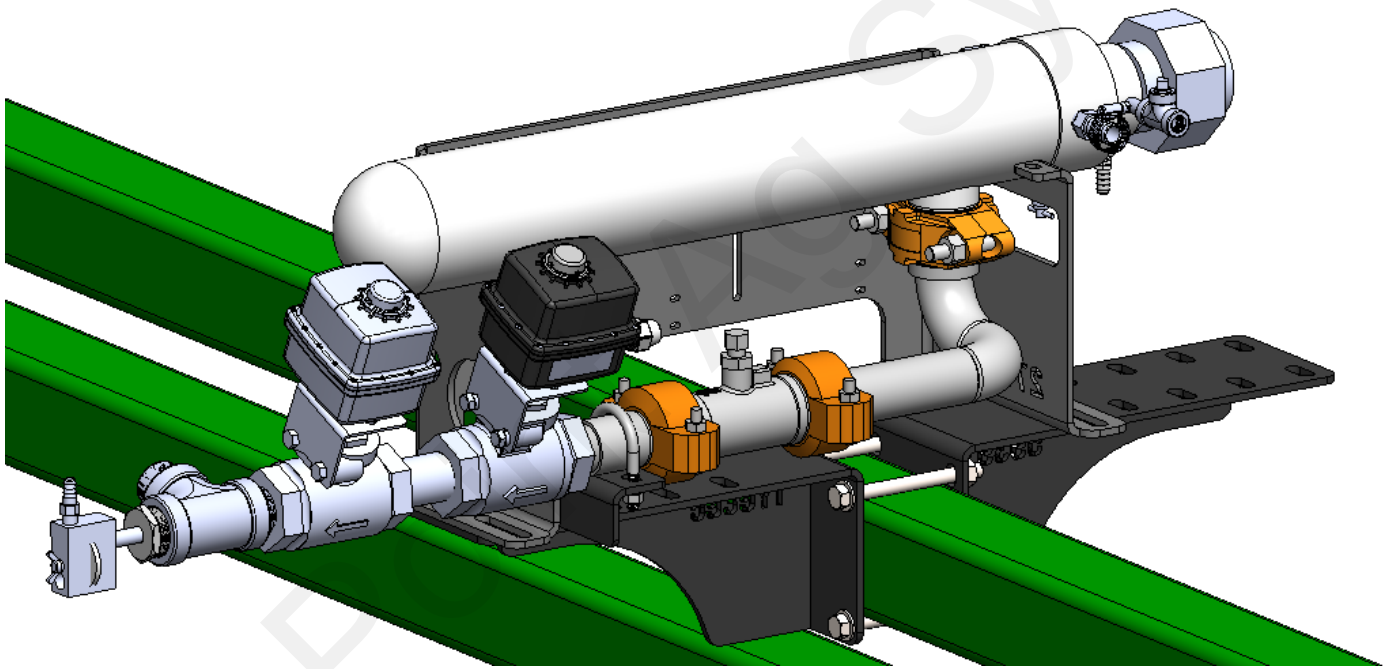

396-6554Y1

NH3 Torpedo Update Instructions For Torpedo with Zip Vapor Valve





Safety

A

TAKE NOTE! THIS SAFETY ALERT SYMBOL FOUND THROUGHOUT THIS MANUAL IS USED TO CALL YOUR ATTENTION TO INSTRUCTIONS INVOLVING YOUR PERSONAL SAFETY AND THE SAFETY OF OTHERS. FAILURE TO FOLLOW THESE INSTRUCTIONS CAN RESULT IN INJURY OR DEATH.



**THIS SYMBOL MEANS
ATTENTION!
BECOME ALERT!
YOUR SAFETY IS INVOLVED!**

Note the use of the signal words DANGER, WARNING and CAUTION with the safety messages. The appropriate signal word for each has been selected using the following guidelines:



DANGER: Indicates an imminently hazardous situation that, if not avoided, will result in death or serious injury. This signal word is to be limited to the most extreme situations typically for machine components which, for functional purposes, cannot be guarded.



WARNING: Indicates a potentially hazardous situation that, if not avoided, could result in death or serious injury, and includes hazards that are exposed when guards are removed. It may also be used to alert against unsafe practices.



CAUTION: Indicates a potentially hazardous situation that, if not avoided, may result in minor or moderate injury. It may also be used to alert against unsafe practices.

NOTICE is used to address safety practices not related to personal safety.

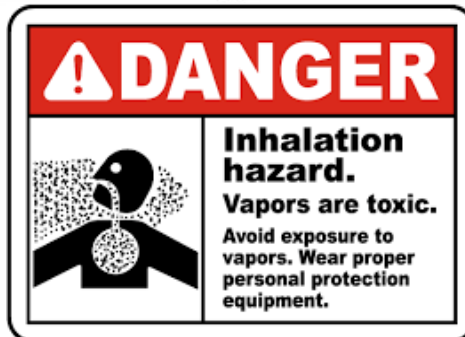



ATTENTION: Please follow all of the instructions in this manual carefully and read the entire manual completely. Failure to do so may cause the product to function improperly or fail causing serious injury or death.



ANHYDROUS AMMONIA IS AN INHALATION HAZARD AND WILL CAUSE SERIOUS INJURY OR DEATH. PLEASE USE EXTREME CAUTION WHEN HANDLING IT OR PERFORMING ANY MAINTENANCE ON EQUIPMENT USED FOR ANHYDROUS AMMONIA.

ATTENTION: Before performing any installation, repair or maintenance please follow the instructions below.

1. You must be trained and certified to work with anhydrous ammonia. If you are not, please seek out the appropriate agricultural department to attend a class to obtain the proper training and certification.
2. Wear appropriate safety goggles, gloves and breathing apparatuses.
3. Always know which way the wind is blowing.
4. Drain all tanks, hoses and piping of anhydrous ammonia COMPLETELY before removing, installing, performing maintenance or repairing any equipment.
5. Always remove device from service before performing any maintenance or repair.
6. Have sufficient water nearby.
7. Obey all local, state and federal laws regarding the handling of anhydrous ammonia.



WARNING

Anhydrous Ammonia Safety

Anhydrous ammonia is an important source of nitrogen fertilizer for crops. The improper handling of anhydrous ammonia can have catastrophic results on both plants and farm workers. Common injuries are severe burns to eyes, skin and the respiratory tract.

- Personal protective equipment (PPE) should always be worn. Standard PPE should be non-vented goggles, rubber gloves with thermal lining, face shield or an approved respirator. Wear a lightweight rubber suit, or (at the very least) a long sleeve shirt and coveralls.
- Make sure anhydrous ammonia tanks are not filled beyond the recommended capacity.
- Use care when handling the hose end valve so that it does not open accidentally. Do not move the hose by handling valve handle.
- Be sure to bleed the hose coupling before disconnecting. Use care when cleaning plugged knives as anhydrous ammonia could be built up behind the plug.
- Use emergency water supply for at least 15 minutes if exposed to anhydrous ammonia and then seek emergency medical attention.
- Always have a small squeeze bottle of fresh water at all times.
- Never assume NH₃ lines are empty, including the lines connected to the Torpedo.
- Make sure the system is completely drained of NH₃. It can hide in low areas of the system. Look for frost on the hose or equipment. That usually means there is NH₃ there.
- Always use high pressure hose when ammonia can be trapped in that segment, such as between the tank and the Torpedo.
- Any place that has a high pressure hose should also have a hydrostatic relief valve and a bleed valve.
- Always handle valves by the body and not by the wheel or latch.
- Always make sure you are upwind of potential NH₃ release points.
- When you park, position NH₃ equipment downwind from dwellings, people, and livestock.
- Close the valve on the tank when you stop.
- The first treatment for anhydrous ammonia exposure is WATER.

NH₃ is a very dangerous product. It can kill you or blind you or worse. If you have not taken an approved NH₃ Safety class, do not work around NH₃. If you have had the course, follow ALL safety precautions ALL the time.

BE CAREFUL !

NOTICE

Before you start applying NH₃—

- Know the wind direction.
- Are the hoses in good condition?
- Has the expiration date been passed on any hose or other dated component?
- Are all fittings clean and free from rust?
- Do low-pressure tubes have any leaks?
- Are any knives plugged?
- Is the tank secure with a locking hitch pin?
- Is the pressure relief valve operating correctly?
- Does the tank have five gallons of fresh water?
- Is PPE available and being worn (goggles, gloves, long-sleeve shirt) ?

Before performing maintenance on the toolbar or equipment—

- Put on gloves and goggles
- Make sure you have emergency water
- Check wind direction and stay upwind
- Park away from buildings, livestock, and people
- Before servicing, close the valve on the NH₃ tank and continue application to bleed the system.
- Be sure the tank valve is closed. Turn the Master valve on and leave it on during bleeding.
- Disconnect the nurse tank supply hoses.
- Open all bleeder valves on cooler and rest of system.
- Check any hoses that have a low loop in them
- Even after bleeding the system, slowly and cautiously loosen any fittings to be sure there is no ammonia trapped inside.

Regular Maintenance—

- Check unit regularly for leaks and wear
- Clean the unit and, if possible, store inside out of the weather
- If the unit is leaking from a weld seam, remove from service and send in for repair
- If leaking from a threaded connection, try tightening the connection with a wrench
- If leaking from the dump knives when not applying, install a repair kit on the Torpedo to replace the internal O-rings. Also, may need to install a repair kit on the Master shutoff valve (O-rings and seals).

Torpedo Maintenance

- Close the valve on the nurse tank
- Open all valves to drain the system of ammonia
- Open all bleeder valves and drain flush valve on the Torpedo

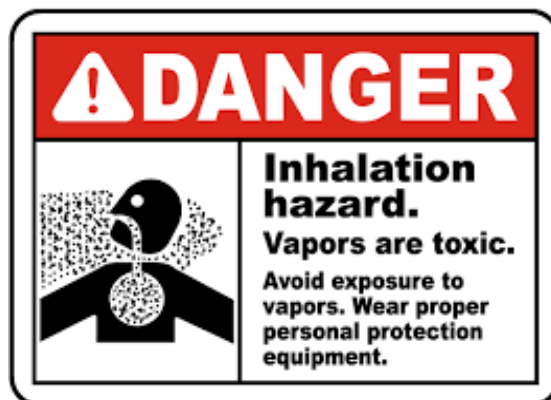

Things to Know About Anhydrous Ammonia (NH₃)

Anhydrous ammonia is a colorless non-flammable liquefied gas. Its vapor is lighter than air and has the same pungent odor as household ammonia. Although ammonia vapor is lighter than air, the vapors from a leak may hug the ground appearing as a white cloud. Chemically, ammonia is 82% nitrogen (N) and 18% hydrogen (H) and has the chemical formula NH₃. Ammonia by weight is 14 parts nitrogen to 3 parts hydrogen, or approximately *82% nitrogen and 18% hydrogen*.

The definition of *anhydrous* is *without water*. Whereas household ammonia is 95% water, anhydrous ammonia has no water. Ammonia is so hydroscopic (water loving) that one cubic foot of water will dissolve 1300 cubic feet of ammonia vapor making water the primary weapon for first responders.

Ammonia weighs 5.15 pounds per gallon in contrast to water which weighs 8.33 pounds per gallon. Since ammonia is so soluble in water there will be no layering effect when liquid ammonia is spilled into a surface water body. Booms, pads, sweeps and pillows that are usually used to contain and recover petroleum are ineffective on spills of ammonia into surface water.

Ammonia is a non-flammable gas but will ignite at a temperature of 1204°F within vapor concentration limits between 15% and 28%. (Paper ignites at 450°F, coal at 750°F.) Outside conditions that would support these vapor concentrations are very rare.

Ammonia will corrode galvanized metals, cast iron, copper, brass, or copper alloys. All ammonia piping, valves, tanks and fittings are constructed of steel.

Liquid ammonia boils at any temperature greater than -28°F and will expand to 850 times its liquid volume. One gallon of liquid will expand to 850 gallons or 113 cubic feet of gas.

Ammonia Fast Facts

NH₃ Vapor

Ammonia appears in nature as a natural substance that results from decomposition.

Ammonia vapor is a colorless gas with a pungent odor.

Ammonia exists as a vapor at atmospheric conditions.

Ammonia vapor is lighter than air and tends to rise when released to atmosphere.

NH₃ Liquid

Liquid ammonia released to atmosphere forms a white smoke by freezing the moisture in the air.

Liquid ammonia has a very high coefficient of expansion with temperature.

One gallon of liquid ammonia weighs approximately 5.15 lbs.; however the weight varies with temperature.

When liquid ammonia reaches a temperature between its melting and critical points, it exerts a vapor pressure that increases with temperature.

A closed container of liquid ammonia is in equilibrium with ammonia vapor and the container pressure bears a definite relationship to the temperature.

Physical Data

Boiling point is -28°F.

Ignition point is 1,204°F.

Storage and Handling

Ammonia is stored and transported as a liquid under pressure.

The pressure on the tank is the liquid pressure and remains the same whether the tank is 10% full or 80% full. This pressure is dependent on the temperature of the NH₃.

The maximum filling level of an anhydrous ammonia tank is 85%.

Flammability

Anhydrous ammonia is classified by the DOT as a non-flammable gas.

Ammonia vapor is flammable over a narrow range of 15% to 28% by volume in air and a strong ignition source must be present.

Anhydrous Ammonia Application

Precision application of anhydrous ammonia starts with a proper metering system. It is crucial to be sure the metering and control system is applying what is required.

Accurate metering of anhydrous ammonia is difficult to achieve with a conventional variable orifice meter. Anhydrous ammonia is stored and transported as a liquid. To maintain NH₃ as a liquid it must be kept below -28°F or maintained under pressure. If the temperature of the NH₃ increases above -28°F some of the liquid changes to a gas as the NH₃ begins to boil. Application equipment typically uses tank pressure to deliver NH₃ to the soil. An increase in tank pressure would tend to force more NH₃ through the distribution lines. The actual pounds of NH₃ being applied decreases or increases as tank pressure fluctuates unless continuous adjustments are made to the meter.

If NH₃ is released into the atmosphere it will expand rapidly to occupy a volume 850 times greater than the original liquid. NH₃ readily changes from liquid to gas in the nurse tank and distribution system. Consequently the ratio of NH₃ gas to liquid continually changes as it passes through the distribution lines. About 1% of the liquid will vaporize during the ammonia flow from the tank dip tube to the metering point. 1% liquid when expanded to vapor at 100 lb tank pressure will occupy approximately 25% to 30% of the delivery chamber. At 50 lb tank pressure this increases to over 60% of the delivery chamber occupied by vapor. This makes metering and distributing NH₃ very difficult to do consistently and accurately.



SurePoint Torpedo

Parts Breakdown and Install Instructions for 202-2693Y2

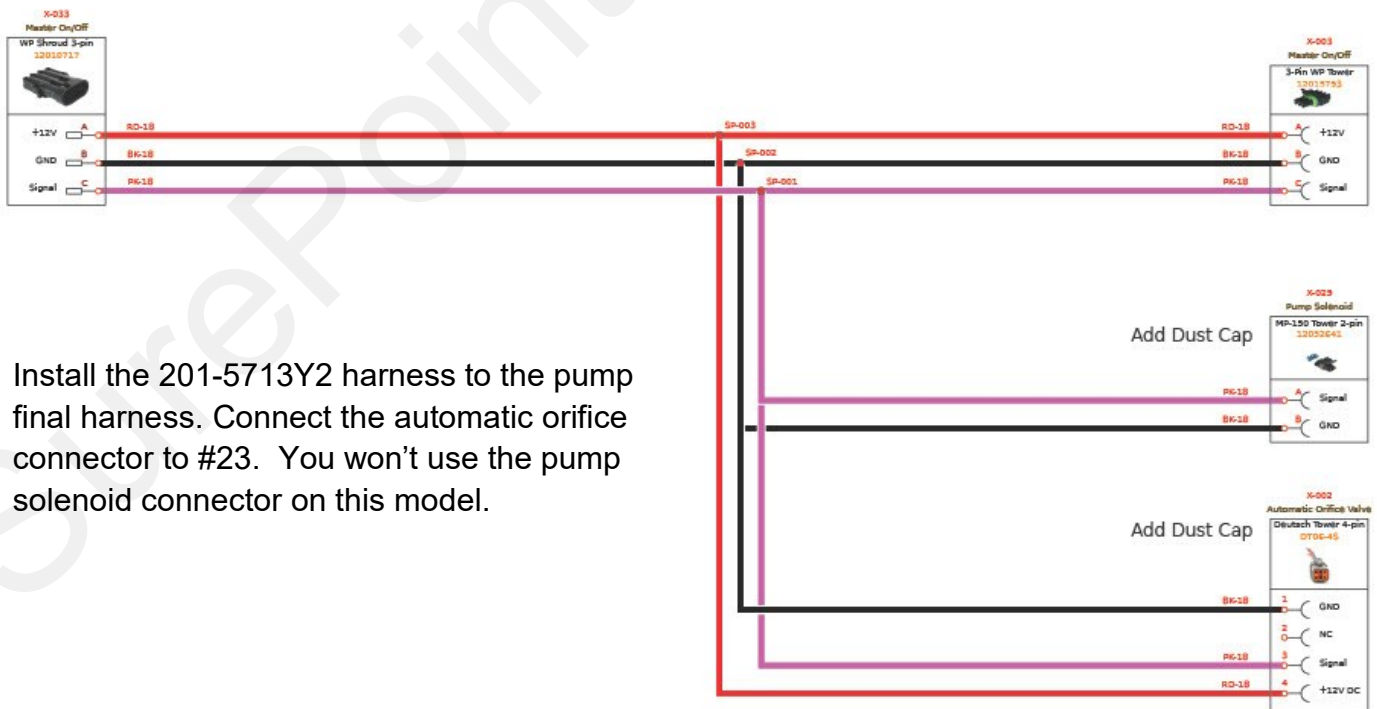
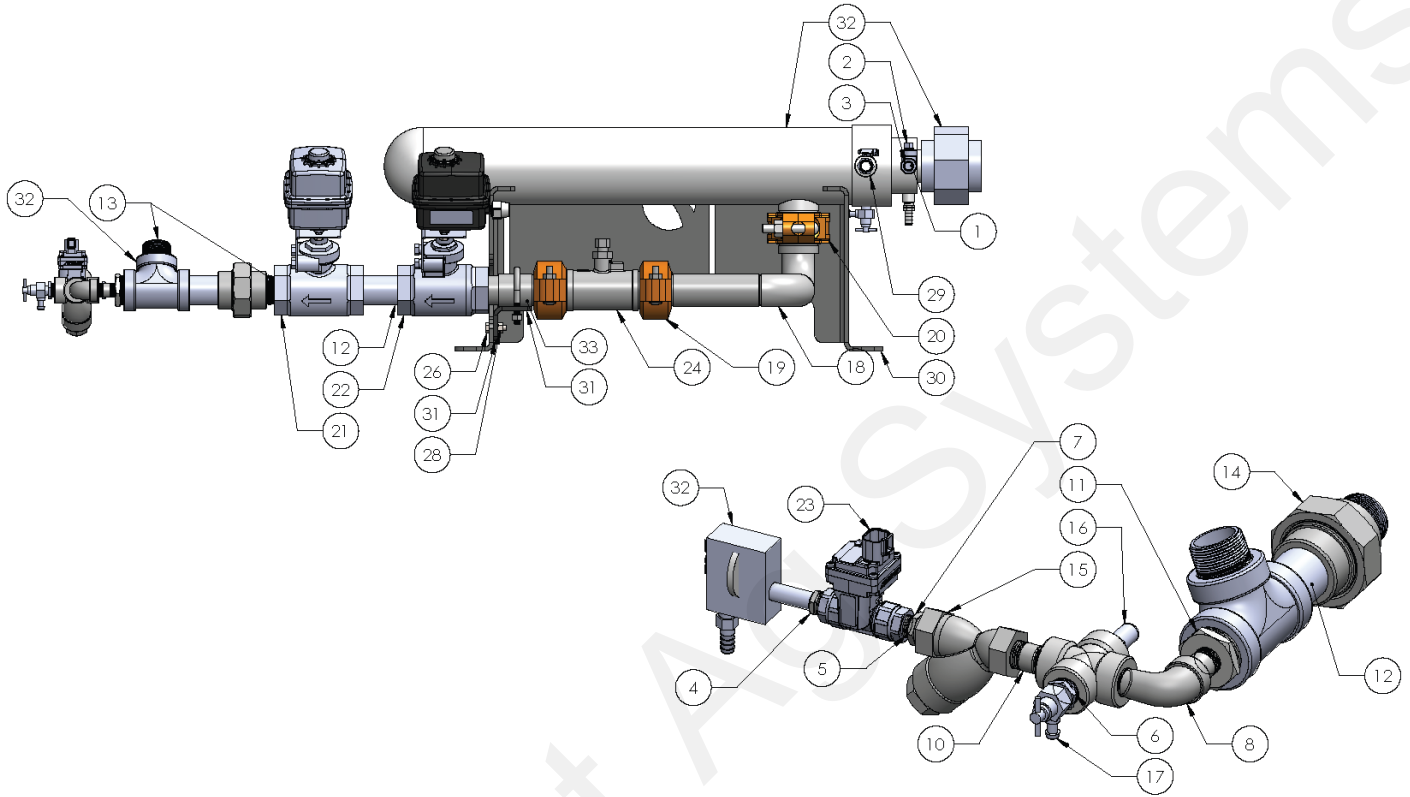

Install the 201-5713Y2 harness to the pump final harness. Connect the automatic orifice connector to #23. You won't use the pump solenoid connector on this model.



SurePoint Torpedo

Updated Parts Breakout with Zip Vapor Valve

202-2693Y2

ITEM NO.	PART NUMBER	DESCRIPTION	QTY.
1	150-025NIP-2-S80	Seamless Sch 80 Black Iron - 1/4" x 2" Nipple	1
2	150-025PLG-S80	1/4" Plug - Schedule 80	1
3	150-025TEE-S80	Forged Steel - 1/4" FPT Tee	1
4	150-038025RB-S80	Forged Steel - 3/8" MPT x 1/4" FPT Reducer Bushing	1
5	150-038NIP-SH-S80	Seamless Sch 80 Black Iron - 3/8" Short Nipple	1
6	150-050025RB-S80	High-Pressure Steel Pipe Fitting	2
7	150-050038RB-S80	304 Stainless Steel Threaded Pipe Fitting	1
8	150-050050SL-90-S80	Medium-Pressure Iron Pipe Fitting	1
9	150-050CR-S80	High-Pressure 304 Stainless Steel Pipe Fitting	1
10	150-050NIP-2-S80	Thick-Wall Welded Steel Pipe Nipple	2
11	150-125050RB-S80	Forged Steel - 1 1/4" MPT x 1/2" FPT Reducer Bushing	1
12	150-125NIP-3-S80	Seamless Sch 80 Black Iron - 1-1/4" x 3" Nipple	2
13	150-125NIP-SH-S80	Seamless Sch 80 Black Iron - 1-1/4" x Short Nipple	2
14	150-125UN-S80	Forged Steel - 1 1/4" Union	1
15	153-02-A1SD-1/2D	A1SD-1/2D - 1/2" FPT Y Strainer for NH3	1
16	153-A-400-B	1/4" RELIEF VALVE - 250 PSI	1
17	153-A-411-HB	Remote Bleed Down Valve with 3/8" Hose Barb	1
18	154-02-5537Y1	Torpedo Discharge Welded Pipe Fitting	1
19	154-04-200150	Victaulic Clamp - 2" x 1-1/2" Reducer	2
20	154-04-200200	Victaulic Clamp - 2"	1
21	202-2691Y1	Control Valve	1
22	202-5520Y1	1-1/4" Full Port NH3 Master Valve Assembly (EH3 Actuator / Continental Valve)	1
23	202-5535Y1	Zip Valve 3/8" Vented Stainless Steel, 2-Way, SS Ball, 3/8" FPT, Deutsch	1
24	204-02-5533Y1	Raven Grooved End Turbine NH3 Flowmeter (063-0173-869)	1
25	283-075-15018574	Bulk 3/4" EVA Clear Reinforced Tubing for NH3	600
26	300-050100-5	5/16" x 1" Hex Head Bolt - G5	2
27	302-0602080300-5	3/8" Round Bend U-Bolt - 2-1/2" x 3"	1
28	323-05	5/16" Flange Nut	2
29	350-1208	SS Hose Clamp - Size 12 - 1-1/4" Diameter	4
30	462-2719Y2	Victaulic Heat Exchanger Base	1
31	462-5692Y1	Round U-Bolt Pipe Support Bracket for Torpedo	1
32	762-A-SF-3000Y2-S-VIC	Victaulic Heat Exchanger	1
33	SF-VIC-150125-4	1 1/2" Grooved End X 1 1/4" MNPT X 4" Long Fitting	1



SurePoint Torpedo

Parts Breakdown and Install Instructions for 202-6479Y1

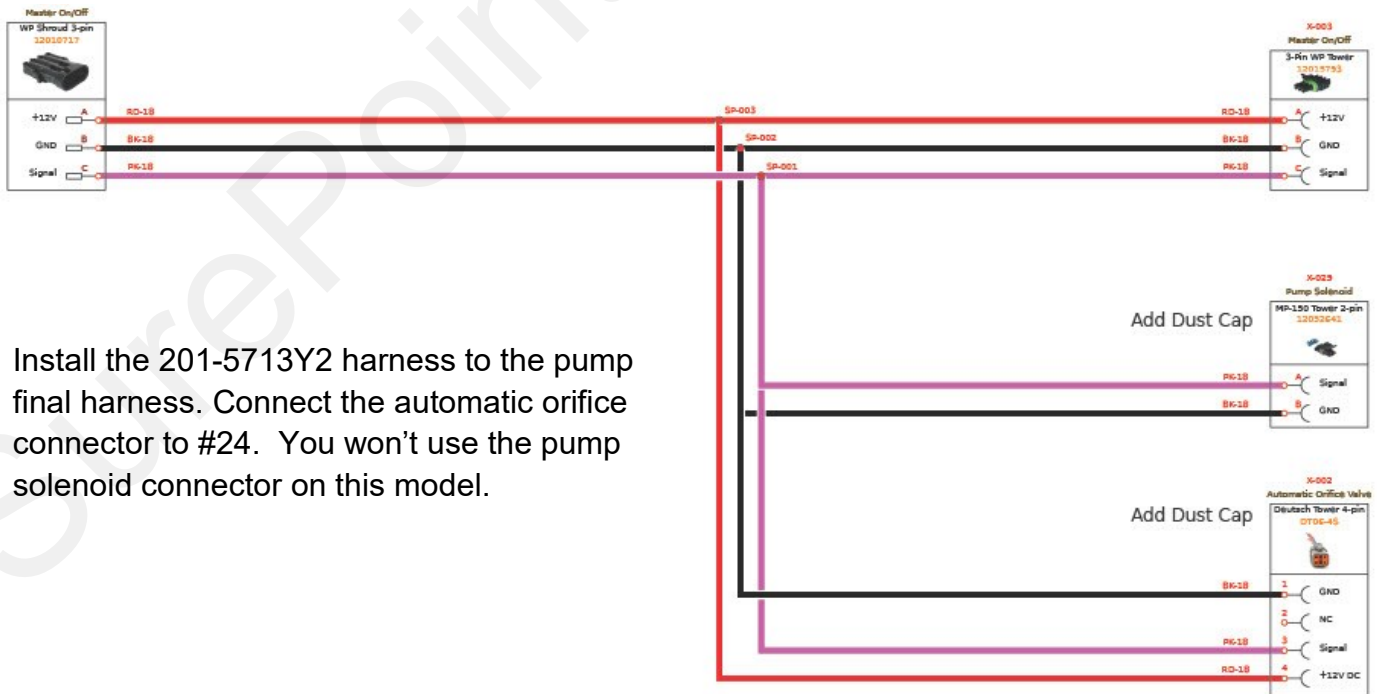
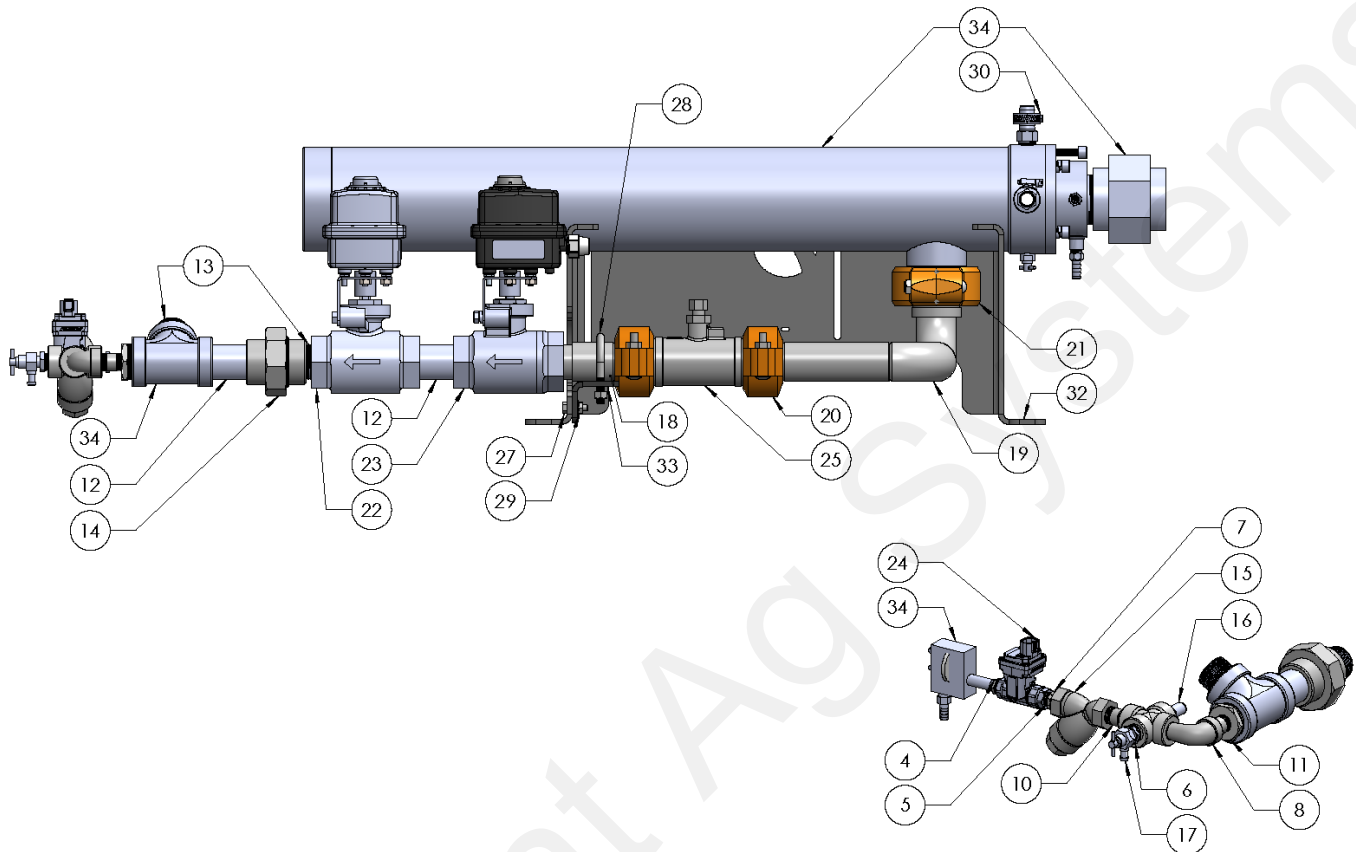

Install the 201-5713Y2 harness to the pump final harness. Connect the automatic orifice connector to #24. You won't use the pump solenoid connector on this model.



SurePoint Torpedo

Updated Parts Breakout with Zip Vapor Valve

202-6479Y1

ITEM NO.	PART NUMBER	DESCRIPTION	QTY.
1	150-025NIP-2-S80	Seamless Sch 80 Black Iron - 1/4" x 2" Nipple	1
2	150-025PLG-S80	1/4" Plug - Schedule 80	1
3	150-025TEE-S80	Forged Steel - 1/4" FPT Tee	1
4	150-038025RB-S80	Forged Steel - 3/8" MPT x 1/4" FPT Reducer Bushing	1
5	150-038NIP-SH-S80	Seamless Sch 80 Black Iron - 3/8" Short Nipple	1
6	150-050025RB-S80	High-Pressure Steel Pipe Fitting	2
7	150-050038RB-S80	304 Stainless Steel Threaded Pipe Fitting	1
8	150-050050SL-90-S80	Medium-Pressure Iron Pipe Fitting	1
9	150-050CR-S80	High-Pressure 304 Stainless Steel Pipe Fitting	1
10	150-050NIP-2-S80	Thick-Wall Welded Steel Pipe Nipple	2
11	150-125050RB-S80	Forged Steel - 1 1/4" MPT x 1/2" FPT Reducer Bushing	1
12	150-125NIP-3-S80	Seamless Sch 80 Black Iron - 1-1/4" x 3" Nipple	2
13	150-125NIP-SH-S80	Seamless Sch 80 Black Iron - 1-1/4" x Short Nipple	2
14	150-125UN-S80	Forged Steel - 1 1/4" Union	1
15	153-02-A1SD-1/2D	A1SD-1/2D - 1/2" FPT Y Strainer for NH3	1
16	153-A-400-B	1/4" RELIEF VALVE - 250 PSI	1
17	153-A-411-HB	Remote Bleed Down Valve with 3/8" Hose Barb	1
18	154-01-150125-4	1 1/2" Grooved End X 1 1/4" MNPT X 4" Long Fitting	1
19	154-02-5537Y1	Torpedo Discharge Welded Pipe Fitting	1
20	154-04-200150	Victaulic Clamp - 2" x 1-1/2" Reducer	2
21	154-04-250200	Victaulic Clamp - 2-1/2" x 2" Reducer	1
22	202-2691Y1	Control Valve	1
23	202-5231Y1	1-1/2" Full Port NH3 Master Valve Assembly (EH3 Actuator / Continental Valve)	1
24	202-5535Y1	Zip Valve 3/8" Vented Stainless Steel, 2-Way, SS Ball, 3/8" FPT, Deutsch	1
25	204-02-5533Y1	Raven Grooved End Turbine NH3 Flowmeter (063-0173-869)	1
26	283-075-15018574	Bulk 3/4" EVA Clear Reinforced Tubing for NH3	50'
27	300-050100-5	BOLT, HEX HEAD, 5/16-18 x 1, GRADE 5	2
28	302-0602080300-5	3/8" Round Bend U-Bolt - 2-1/2" x 3"	1
29	323-05	NUT, SERRATED FLANGE, 5/16-18, GRADE 5	2
30	350-1208	SS Hose Clamp - Size 12 - 1-1/4" Diameter	6
31	398-50-4648Y2	Grey Generic SurePoint Label	1
32	462-2719Y2	Victaulic Heat Exchanger Base	1
33	462-5692Y1	Round U-Bolt Pipe Support Bracket for Torpedo	1
34	762-A-SF-3000J-S-VIC		1



SurePoint Torpedo

Parts Breakdown and Install Instructions for 202-5540Y1

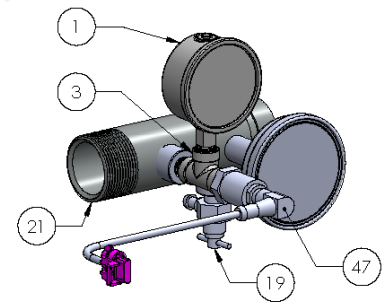
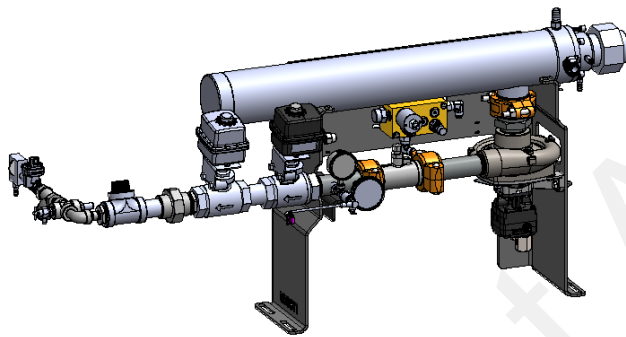
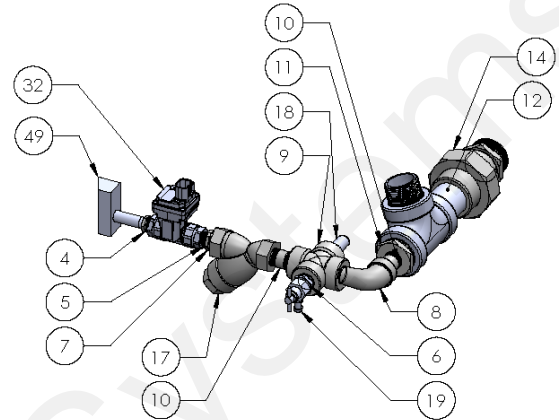
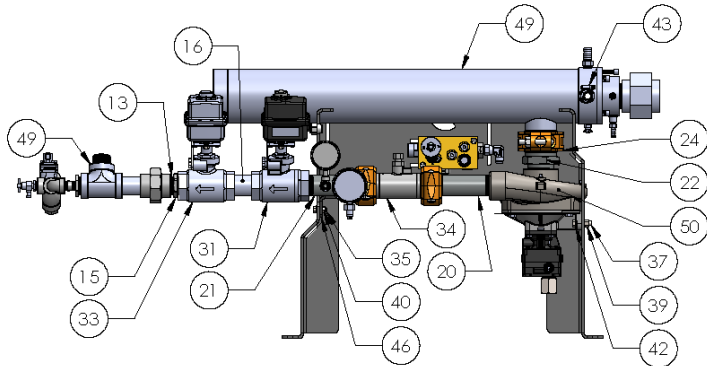

Use #8 JIC fitting to connect to the pressure side of the PWM block with your SCV. The outlet of the pump will use ??? Fitting to return flow to the other port of your SCV. SurePoint recommends 1/2" hydraulic hose.

Use your tractor hydraulic flow valve to control the pump. **Over speeding the pump can cause cavitation and reduce the life of the pump.**

Don't run the pump without product or the pump seal will fail.



SurePoint Torpedo

Parts Breakdown and Install Instructions for 202-5540Y1

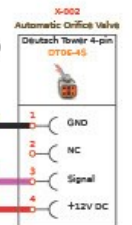
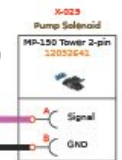
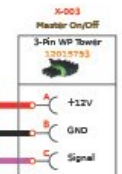
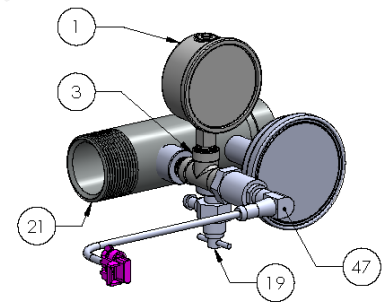
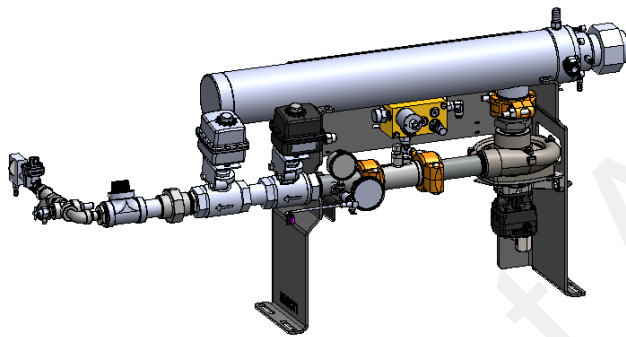
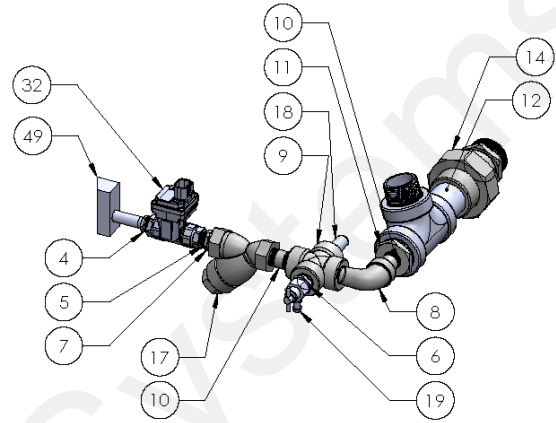
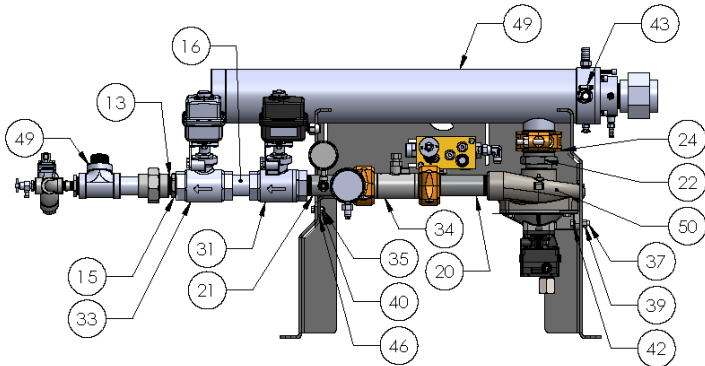

Install the 201-5713Y2 harness to the pump final harness. Connect the automatic orifice connector to #32. The pump solenoid connector will be connected to the pwm solenoid on the hydraulic block. Use your tractor hydraulic flow valve to control the pump. **Over speeding the pump can cause cavitation and reduce the life of the pump.**

Don't run the pump without product or the pump seal will fail.





SurePoint Torpedo

Updated Parts Breakout with Zip Vapor Valve

ITEM NO.	PART NUMBER	DESCRIPTION	QTY.
1	137-LFG400	Pressure Gauge - 2 1/2" Silicone Filled Stainless Gauge - 400 PSI - 1/4" MPT	1
2	140-025NIP-SH	1/4" Close Nipple - SS	1
3	140-025TEE	1/4" SS Tee	1
4	150-038025RB-S80	Forged Steel - 3/8" MPT x 1/4" FPT Reducer Bushing	1
5	150-038NIP-SH-S80	Seamless Sch 80 Black Iron - 3/8" Short Nipple	1
6	150-050025RB-S80	High-Pressure Steel Pipe Fitting	2
7	150-050038RB-S80	304 Stainless Steel Threaded Pipe Fitting	1
8	150-050050SL-90-S80	Medium-Pressure Iron Pipe Fitting	1
9	150-050CR-S80	High-Pressure 304 Stainless Steel Pipe Fitting	1
10	150-050NIP-2-S80	Thick-Wall Welded Steel Pipe Nipple	2
11	150-125050RB-S80	Forged Steel - 1 1/4" MPT x 1/2" FPT Reducer Bushing	1
12	150-125NIP-3-S80	Seamless Sch 80 Black Iron - 1-1/4" x 3" Nipple	1
13	150-125NIP-SH-S80	Seamless Sch 80 Black Iron - 1-1/4" x Short Nipple	2
14	150-125UN-S80	Forged Steel - 1 1/4" Union	1
15	150-150125RB-S80	Forged Steel - 1 1/2" MPT x 1 1/4" FPT Reducer Bushing	1
16	150-150NIP-3-S80	Seamless Sch 80 Black Iron - 1 1/2" x 3" Nipple	1
17	153-02-A1SD-1/2D	A1SD-1/2D - 1/2" FPT Y Strainer for NH3	1
18	153-A-400-B	1/4" RELIEF VALVE - 250 PSI	1
19	153-A-411-HB	Remote Bleed Down Valve with 3/8" Hose Barb	2
20	154-01-150150-6	1-1/2" OGS x 1-1/2" MPT - 6" Long Adapter	1
21	154-01-150150-G6	Torpedo Gauge Assembly - 1-1/2" OGS x 1-1/2" MPT with Gauge Ports	1
22	154-01-200250-3	2" MNPT x 2-1/2" Grooved End - 3" Long	1
23	154-04-200150	Victaulic Clamp - 2" x 1-1/2" Reducer	2
24	154-04-250250	Victaulic Clamp - 2-1/2"	1
25	161-01-12MB-8MJ	Adapter - #12 Male Boss x #8 Male JIC	2
26	161-02-8MB-8MJ90	#8 Male O-Ring Boss x #8 Male JIC - 90	1
27	161-02-8MJ-8FJX-90	Elbow - #8 Female JIC x #8 Male JIC - 90	2
28	163-01-XXXX-08	Hydraulic Hose Assembly - 16" of 1/2" Hydraulic Hose - #8 Female JIC x #8 Female JIC	1
29	165-P15618A-3	PWM Valve for Planting/Seeding or Multiple Section Applications (load sense and needle valve)	1
30	201-5713Y1	Torpedo Pump Solenoid Engage Harness	1
31	202-5231Y1	1-1/2" Full Port NH3 Master Valve Assembly (EH3 Actuator / Continental Valve)	1
32	202-5535Y1	Zip Valve 3/8" Vented Stainless Steel, 2-Way, SS Ball, 3/8" FPT, Deutsch	1
33	202-5555Y1	SurePoint 1-1/2" NH3 Servo Valve- 7 sec. 118 Degree open/close - 3-pin WP Tower (2 wire)	1
34	204-02-5533Y1	Raven Grooved End Turbine NH3 Flowmeter (063-0173-869)	1
35	300-050100-5	5/16" x 1" Hex Head Bolt - G5	2
36	300-050308-5	BOLT, HEX HEAD, 5/16-18 x 3-1/2, GRADE 5	2
37	300-060108-5	3/8" x 1-1/2" Hex Head Bolt - G5	2
38	302-0602080300-5	3/8" Round Bend U-Bolt - 2" x 3"	1
39	321-06	3/8" Nylock Nut	2
40	323-05	5/16" Flange Nut	4
41	330-05	5/16" Flat Washer	2
42	330-06	3/8" Flat Washer	2
43	350-1208	SS Hose Clamp - Size 12 - 1-1/4" Diameter	4
44	398-50-4648Y2	Grey Generic SurePoint Label	1
45	462-5539Y1	Heat Exchanger Base	1
46	462-5692Y1	Round U-Bolt Pipe Support Bracket for Torpedo	1
47	521-05-050400	NH3 400 PSI 3 wire pressure sensor (0-5 VDC) with 3-pin 150 MP Tower Connector	1
48	757-3989K81	Compact Threaded Thermometer - 2-1/2" Long Stem, 3" Dial Diameter	1
49	762-A-SF-3000J-S-VIC		1
50	9306S-HM5C	Stainless Centrifugal Pump / Hydraulic Motor Unit - 2" x 1-1/2", 212 Max GPM, 140 Max PSI	1