

396-6553Y1



SENTINEL

**Sentinel Dry
Rate Control**
for ISOBUS
Installation and Setup



SurePoint Ag Systems



Read this Manual and keep it in the cab.

Other Resources

396-4953Y1 Manual for PumpRight System using Sentinel Rate Control

396-4954Y1 Manual for Tower System using Sentinel Rate Control

396-4608Y1 Gen3 LiquiShift Manual

396-4034Y1 PumpRight Pump Manual

396-4035Y1 Sentinel Liquid Row Monitor and Rate Control

396-5477Y1 Sentinel Row Control

[Sentinel support site](https://support.surepointag.com/products/346) <https://support.surepointag.com/products/346>

- Manuals
- ECU Software Update
- Videos
- Support Bulletins

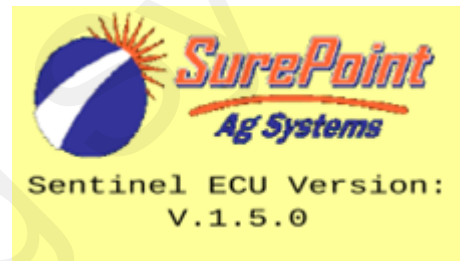

System Summary (helpful for tech support)

System Purchased from: _____

Date Purchased: _____

S0 number from Sales Order: S0 _____

Using Sentinel for: Row Monitoring Rate Control Gen3 LiquiShift

Pump: Electric PR17 PR30 PR40 D250

Implement: _____

Metering Tube colors _____ & _____ 8' 5' Other

Implement Width _____ Rows _____ Spacing _____ Sections _____

Table Of Contents

Introduction

- Basic Steps to Install your Sentinel System 1



Components - Wiring & Electrical

- Harness Overview / Layout..... 2
- Harness Drawings - 4984Y2 Row Control 4 Product 3-8
- Harness Drawings - 5022Y2 - Rate Control /Row Monitoring 2 Product 9-14
- Harness Drawings - 5993Y1 –Row Control 4 Product with Multi PWM 15-21
- Harness Drawings - 6491Y1 –Sentinel 2000 Hyd. Drive 6 sc.+ Liquid/NH3 22-26
- Harness Drawings –207-3492Y2 12 Pin Final Cable for Dry Fertilizer 27
- Harness Drawings –207-6500Y1 Sentinel Hyd. Drive Final Harness 28
- Front ISO Extension 29

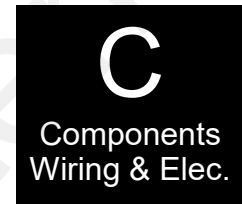

Setup & Operation

- Sentinel Dry Control..... 25
- Sentinel Icons 26

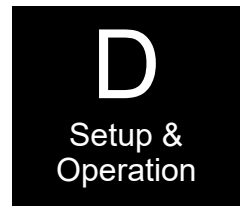

Dry Control

- **Sentinel Dry Control Setup..... 27-43**
- Basic Setup Overview 27
- Home Screen Navigation 28
- Setup Tab 29
- Operate Tab Operations 30
- Product and Mode Selection 31
- Rate Mode Setup 32
- Implement, Speed , Hardware: Foot switch, Height switch, Task Control..... 33
- Global Settings 34
- Sentinel Version and Auxiliary Setting 35
- Customizable Toolbar & Totalizer Counters..... 36
- Manual Operations 37
- Nozzle Test..... 38
- Catch Test 39-40
- Trouble Shooting 41
- Care and Maintenance..... 42
- Sentinel Accessories 43

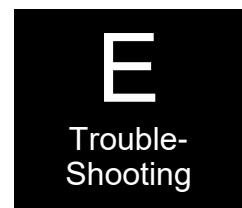

SurePoint Ag Systems

© 2017-2023 SurePoint Ag Systems—All Rights Reserved



396-6553Y1

Sentinel Dry Control

Revised 03/12/2024



Safety

TAKE NOTE! THIS SAFETY ALERT SYMBOL FOUND THROUGHOUT THIS MANUAL IS USED TO CALL YOUR ATTENTION TO INSTRUCTIONS INVOLVING YOUR PERSONAL SAFETY AND THE SAFETY OF OTHERS. FAILURE TO FOLLOW THESE INSTRUCTIONS CAN RESULT IN INJURY OR DEATH.



**THIS SYMBOL MEANS
ATTENTION!**

BECOME ALERT!

YOUR SAFETY IS INVOLVED!

Note the use of the signal words DANGER, WARNING and CAUTION with the safety messages. The appropriate signal word for each has been selected using the following guidelines:



DANGER: Indicates an imminently hazardous situation that, if not avoided, will result in death or serious injury. This signal word is to be limited to the most extreme situations typically for machine components which, for functional purposes, cannot be guarded.



WARNING: Indicates a potentially hazardous situation that, if not avoided, could result in death or serious injury, and includes hazards that are exposed when guards are removed. It may also be used to alert against unsafe practices.



CAUTION: Indicates a potentially hazardous situation that, if not avoided, may result in minor or moderate injury. It may also be used to alert against unsafe practices.

NOTICE is used to address safety practices not related to personal safety.





Hydraulic Fluid and Equipment Safety

This system uses hydraulic equipment with hydraulic fluid under extremely high pressure.

Hydraulic fluid escaping under pressure can have sufficient force to penetrate the skin causing serious injury. Keep all hoses and connections in good serviceable condition. Failure to heed may result in serious personal injury or death. Avoid the hazard by relieving the pressure before disconnecting lines or performing work on the system.

Make sure hydraulic fluid connections are tight and all hydraulic hoses and lines are in good condition before applying pressure to the system. Use a piece of paper or cardboard, NOT BODY PARTS, to check for suspected leaks. Wear protective gloves and safety glasses or goggles when working with hydraulic systems. DO NOT DELAY!

Check hydraulic hoses and fittings frequently. Loose, broken, and missing hardware can cause equipment to not perform properly and can result in serious injury or death. Hydraulic systems can be hot and cause burns. Before working on any system, wait until the fluid has cooled.

If an accident occurs, see a doctor familiar with this type of injury immediately. Any fluid injected into the skin or eyes must be treated within a few hours or gangrene may result.

A Word to the Operator



It is YOUR responsibility to read and understand the safety messages in this manual. YOU are the key to safety.

SAFETY IS YOUR RESPONSIBILITY.

SurePoint Ag Systems



General Description

A

Introduction

You have purchased a SurePoint Sentinel system for your equipment. This system will be controlled by the Sentinel ECU through your in-cab ISO display. This manual walks you through the general layout, harnessing, and setup for dry applications with the Sentinel Rate Control.

Disclaimer: The harnessing and items shown are for SurePoint products that we sell and service. If any modifications are made to the harnessing or connectors that could void your warranty. Please contact your dealer for support questions.

SurePoint currently supports Sentinel operating on the following displays: **John Deere** 2630, 4640, & G5 **Ag Leader InCommand** 800 and 1200, **Case IH** Pro 700 and Pro 1200, and **Trimble** TMX-1060 or 1260. The use of Sentinel on any other display may result in diminished functionality.

A 2-pin Molex power and 12-pin Ampseal Power/CAN connector are required on your implement to connect the Sentinel ECU to the implement bus. While some equipment manufacturers already provide this connection, SurePoint offers harnessing to provide this connection on any implement. Ask your SurePoint representative what accommodations may be needed for your specific equipment.

Basic Installation Steps for Dry Control

1. Mount your Hydraulic PWM motor or control valve to drive your shaft.
2. Mount your encoder or barrel sensor within 3' of your PWM connection. If this isn't possible we can sell extensions to reach any of these connections.
3. If necessary, route the provided ISO extension cable from the implement hitch to the desired Sentinel ECU mounting location.
4. Locate the 2-pin Molex power and 12-pin Ampseal POWER/CAN connectors that the Sentinel ECU will be connected to and remove the terminator.
5. Mount the Sentinel ECU using the provided bracket in a location within 4 feet of the above connection.
6. Attach the Sentinel ECU harness to the Sentinel ECU and plug the other end of the harness into the above Molex/Ampseal POWER/CAN connection.
7. Use the previously removed terminator to terminate the POWER/CAN connection found on the ECU harness.
8. Connect your hydraulic drive final harness into the 12-pin connector on the Sentinel ECU harness.
9. Connect the 2 pin PWM connector to the hydraulic pwm solenoid
10. Connect the Meter RPM sensor to the encoder or barrel sensor

SurePoint Harness Layout for ISO Sentinel

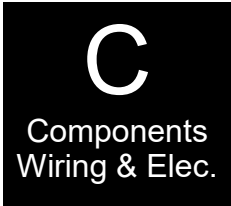

The SurePoint Sentinel module communicates with the Sentinel ECU through a proprietary communication network (CAN). The Sentinel ECU then, using the ISOBUS communication protocol, relays the flow information through the tractor ISOBUS and generates the user interface on the in-cab display. A series of connections are required to form this communication network.

Tractor Connection

Designed to integrate with any implement, in some cases, connecting the Sentinel starts at the tractor's ISOBUS connection. Power and information is relayed to the Sentinel ECU using a SurePoint Front ISO Extension which includes power and CAN bus connections. Already using the tractor ISOBUS? No Problem. SurePoint carries ISOBUS-Y harnesses to split the ISO connection at the tractor.

Implement Height and Speed Input

Not used in all configurations, the implement height and speed input connections provide additional input options in situations that require advanced alarm control and an auxiliary speed source. These conditions generally exist only in hybrid systems, utilizing multi-branded components.

Service Connections

The Terminating Resistor, Programming and RS232 connectors are for service only and should not be used.

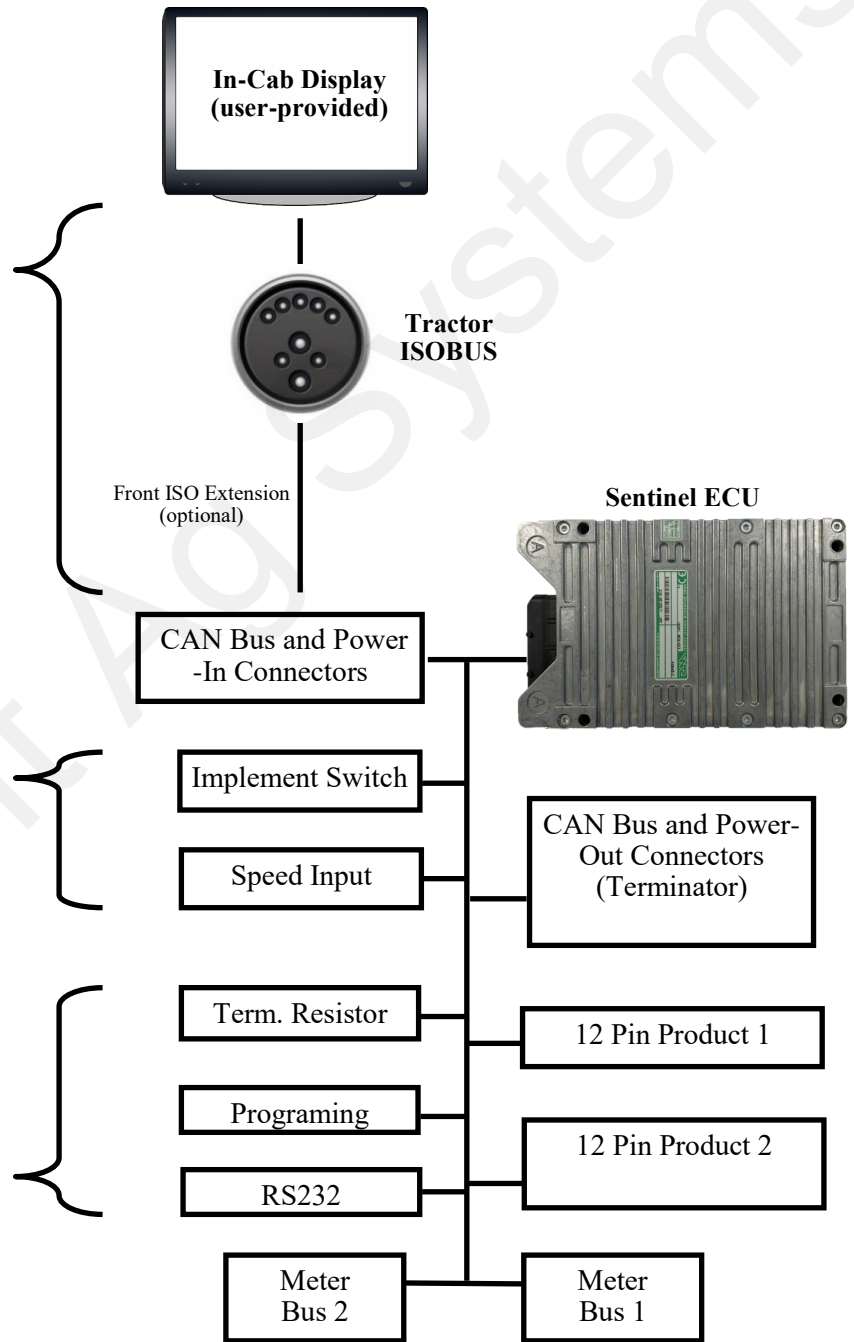

Bus Connections

2 Bus connections are provided for convenience so that each side of the implement can plug into the ECU harness without the need for a long, continuous chain of connections.

208-06-4984Y2 Sentinel Row Control and Flow Monitoring
ECU Harness– 4 Product 18 Sections Page 1 of 6

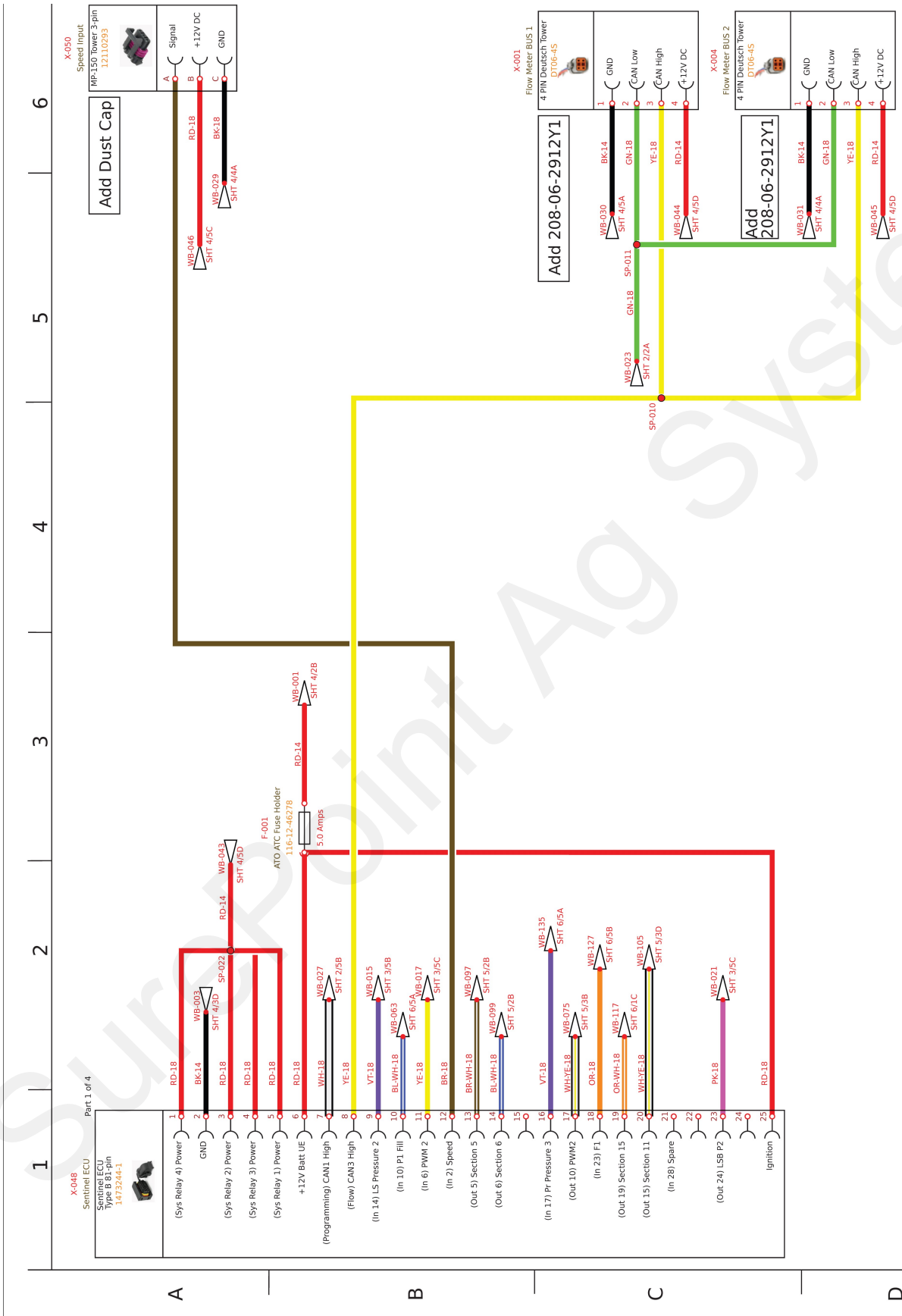

208-06-4984Y2 Sentinel Row Control and Flow Monitoring
ECU Harness– 4 Product 18 Sections Page 2 of 6

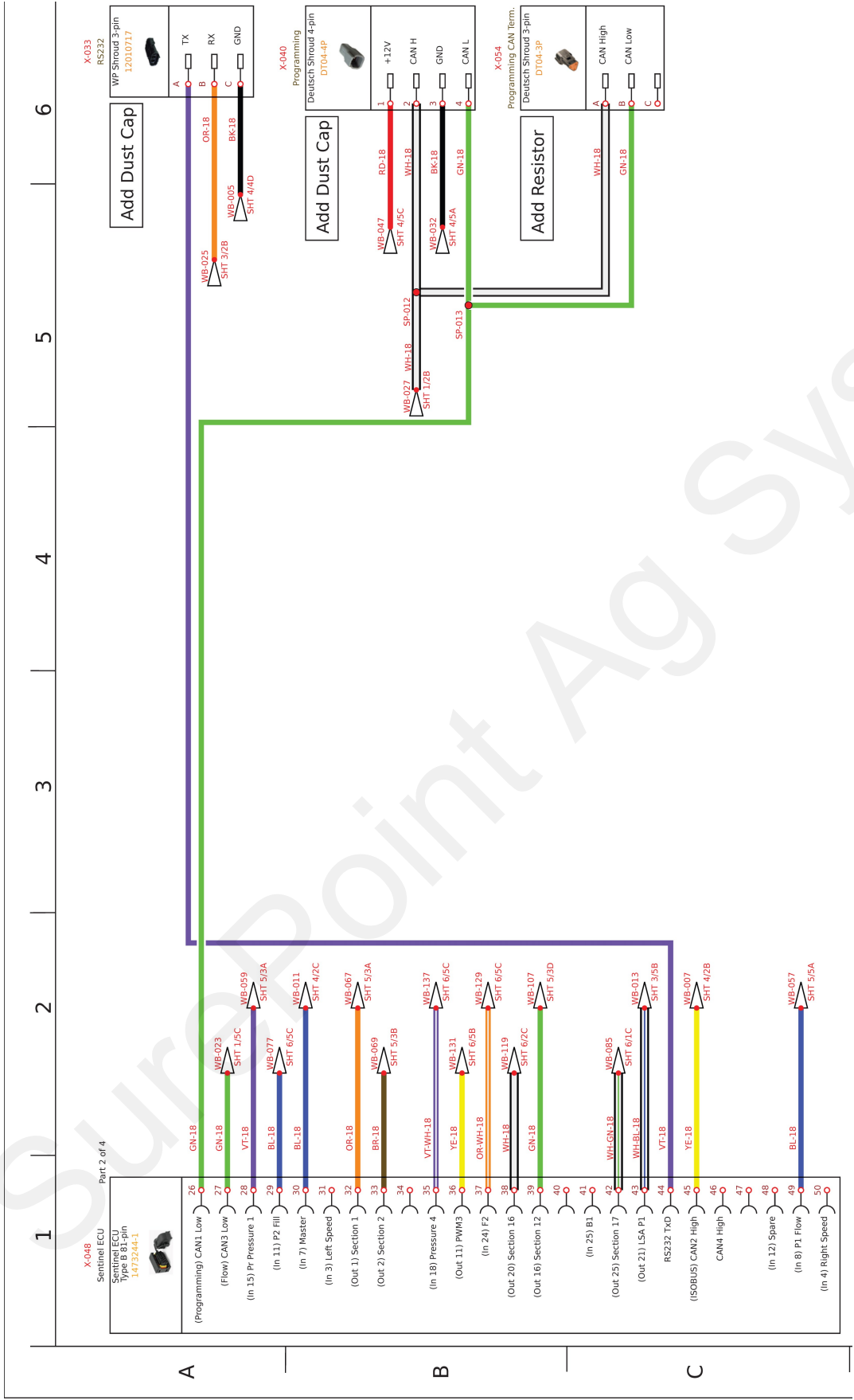

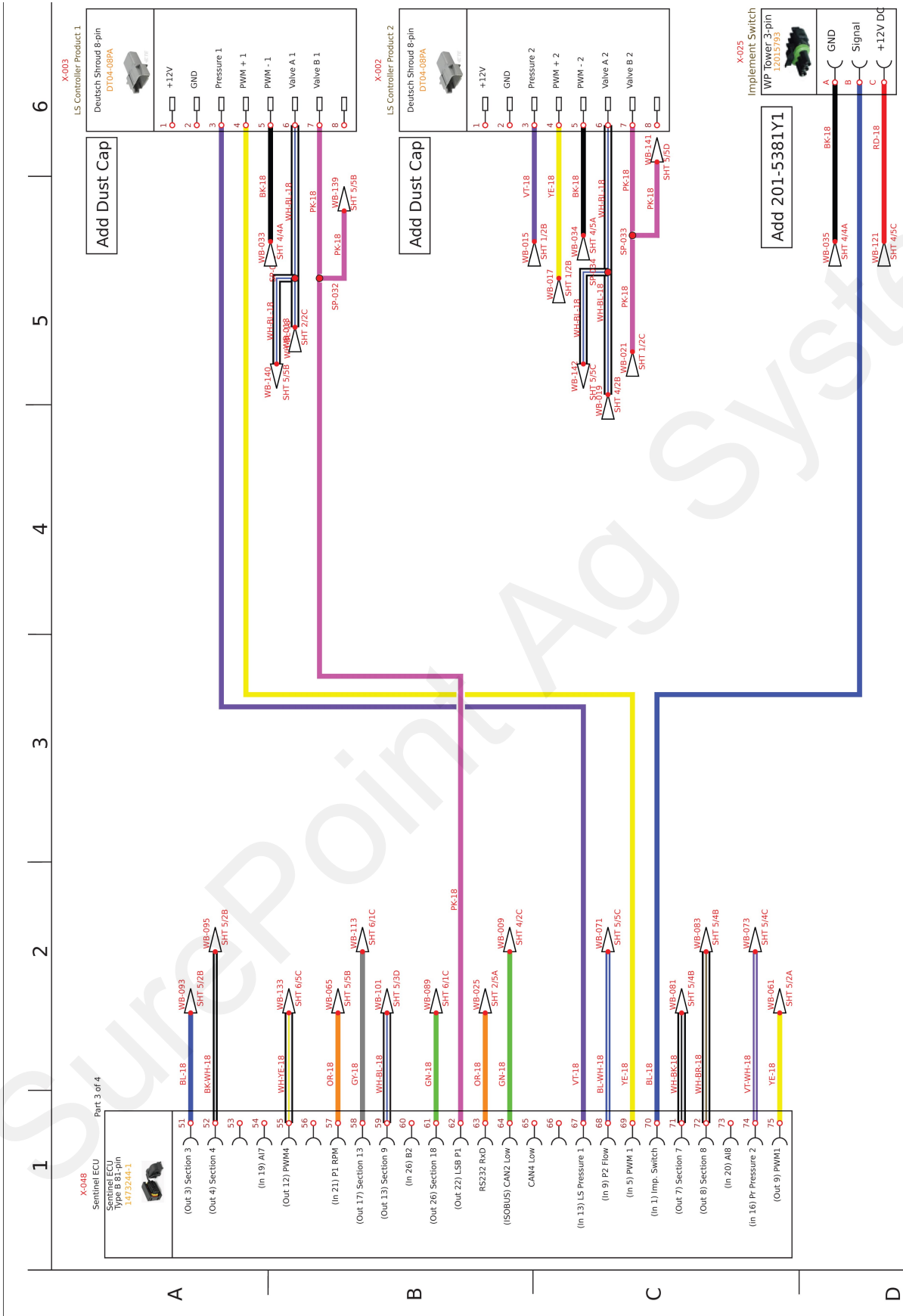

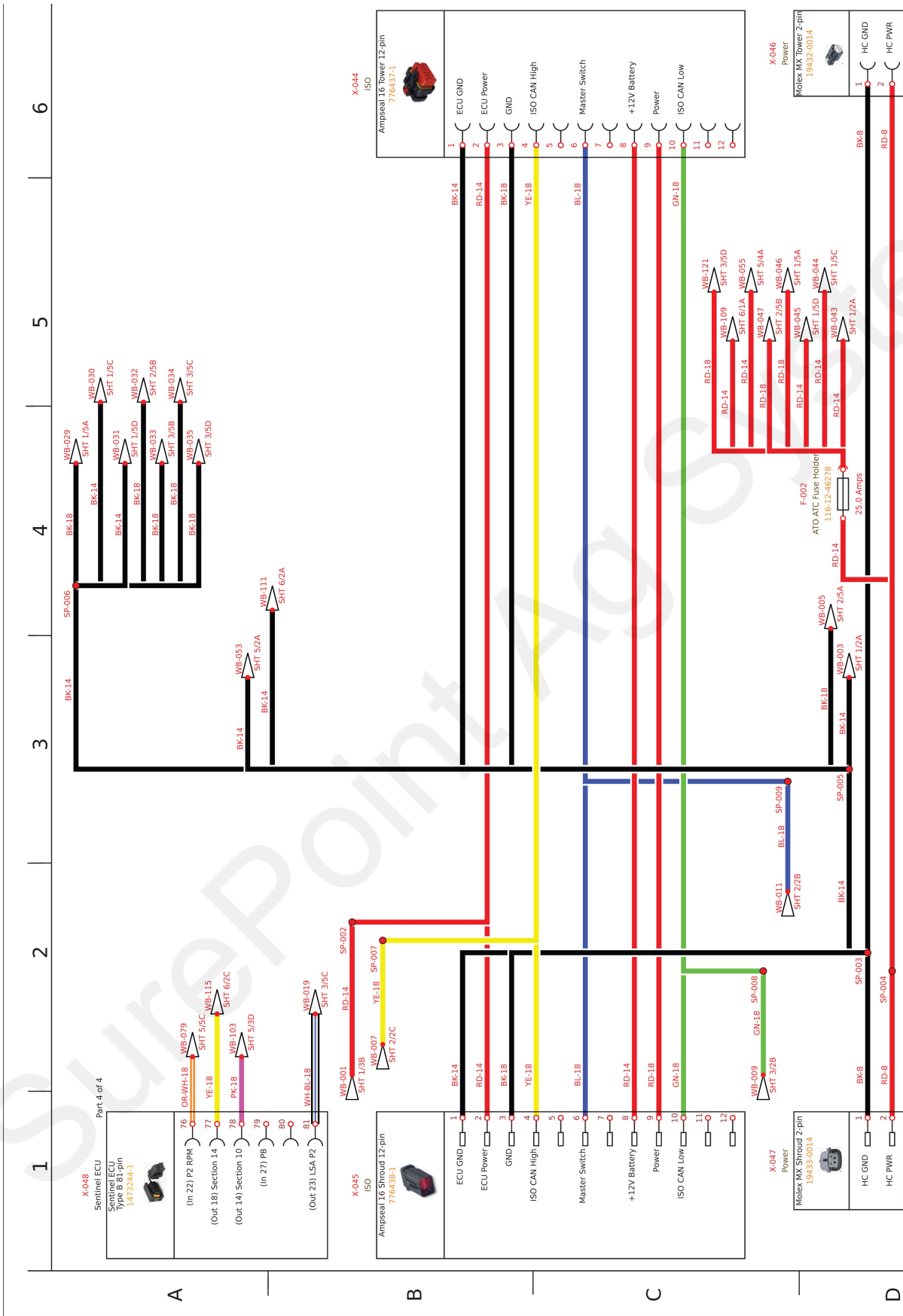

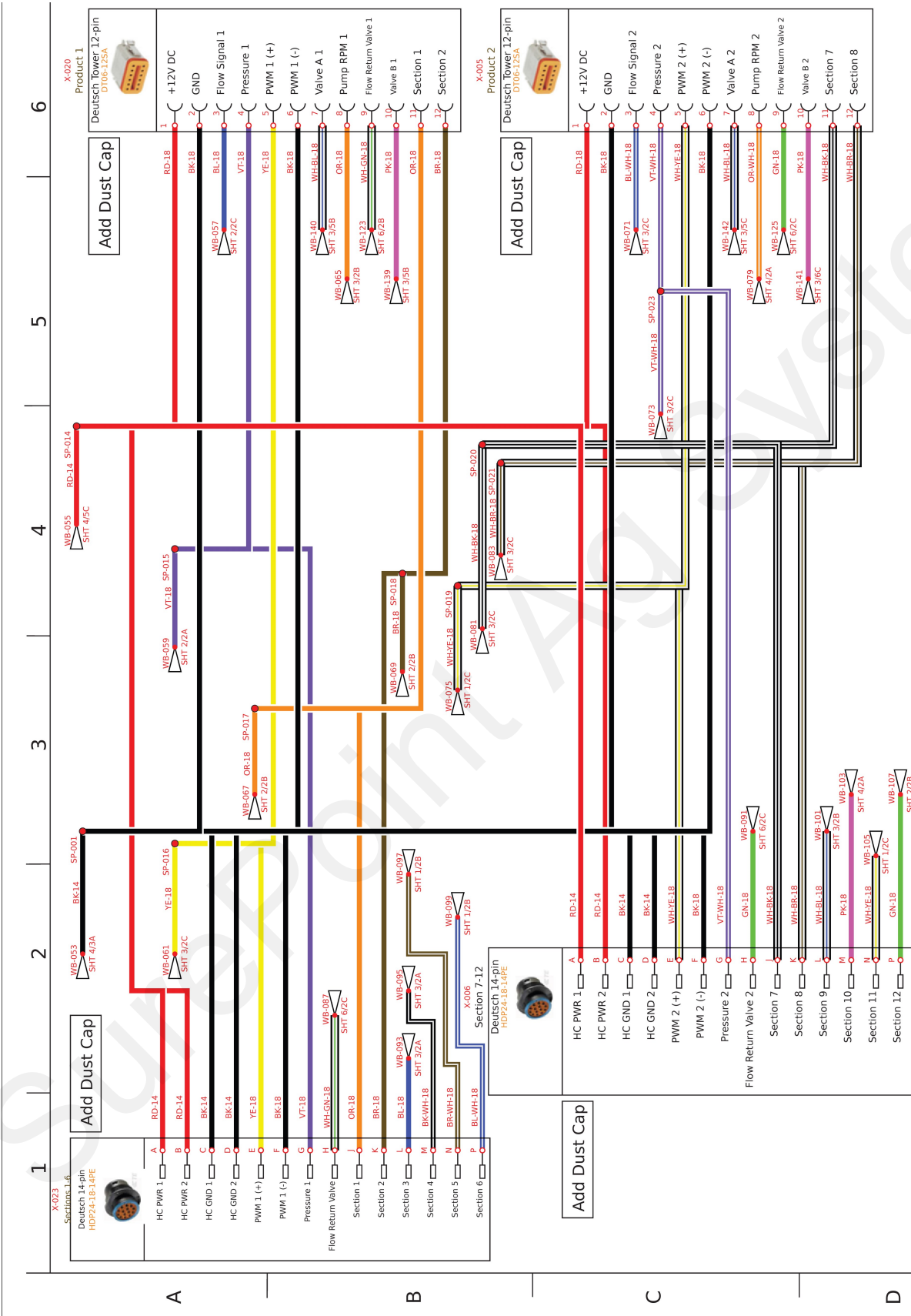

208-06-5022Y2 Sentinel Row Control and Flow Monitoring
ECU Harness– 2 Product 18 Sections Page 1 of 6

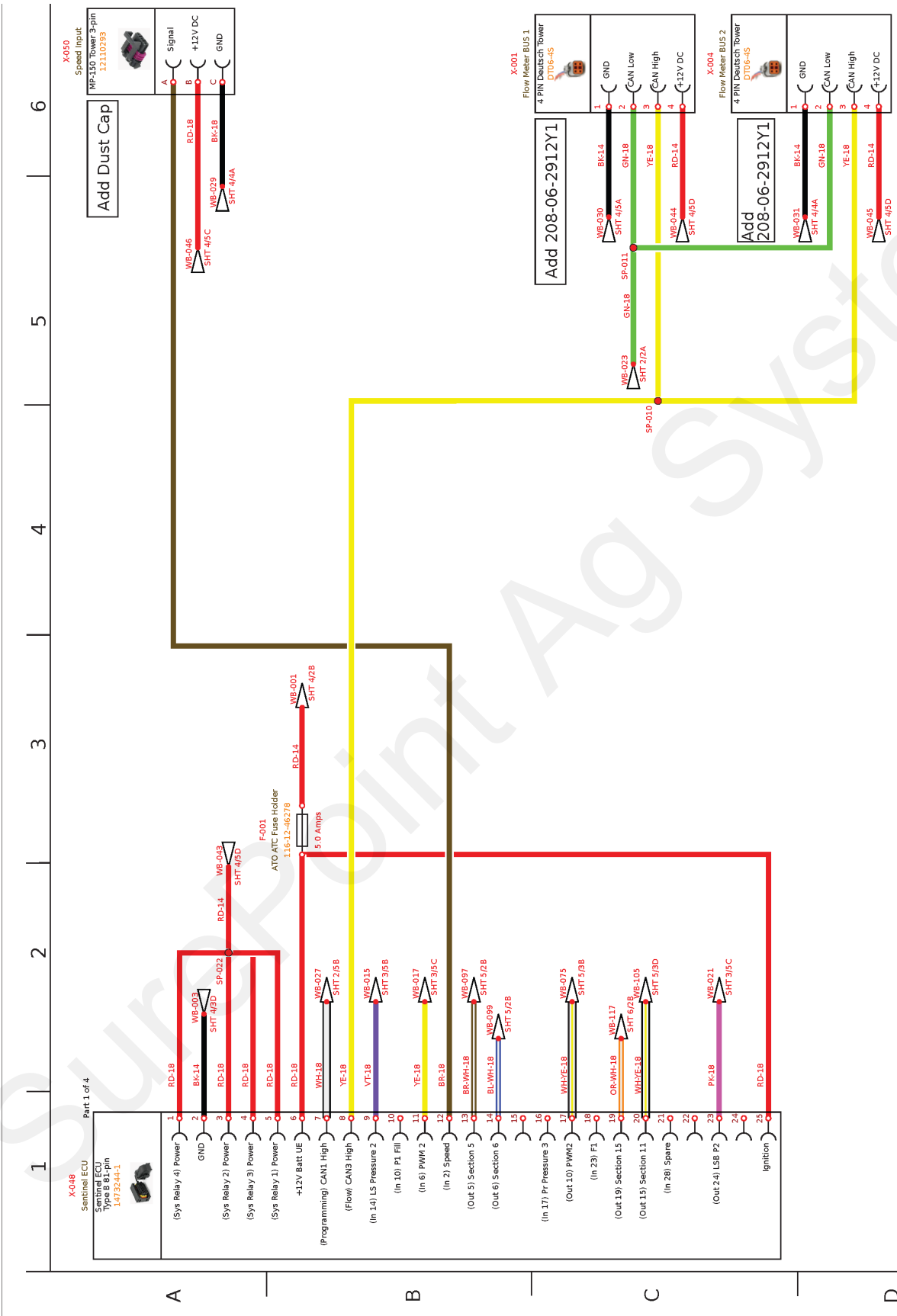

208-06-5022Y2 Sentinel Row Control and Flow Monitoring
ECU Harness– 2 Product 18 Sections Page 2 of 6

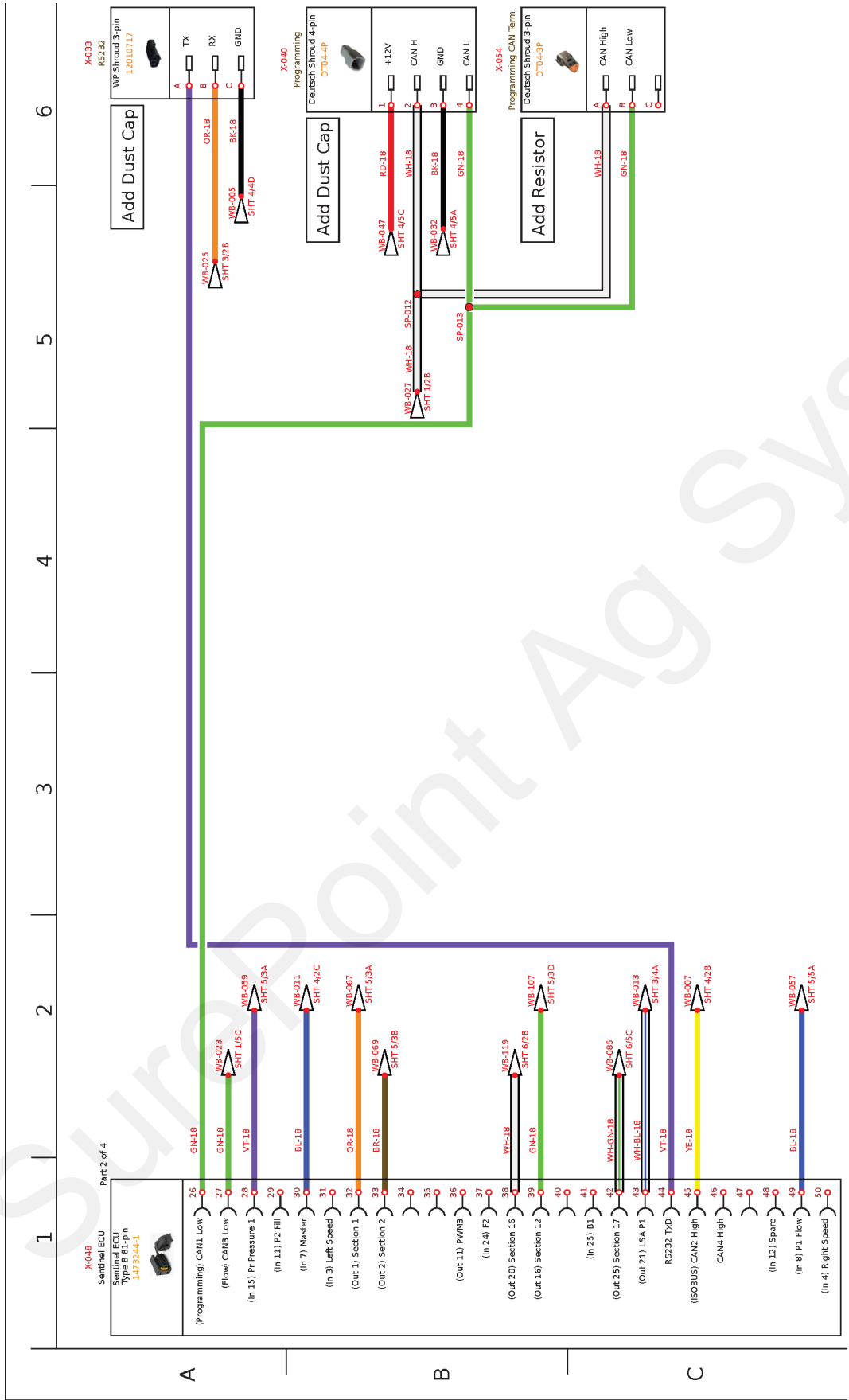

208-06-5022Y2 Sentinel Row Control and Flow Monitoring
ECU Harness– 2 Product 18 Sections Page 3 of 6

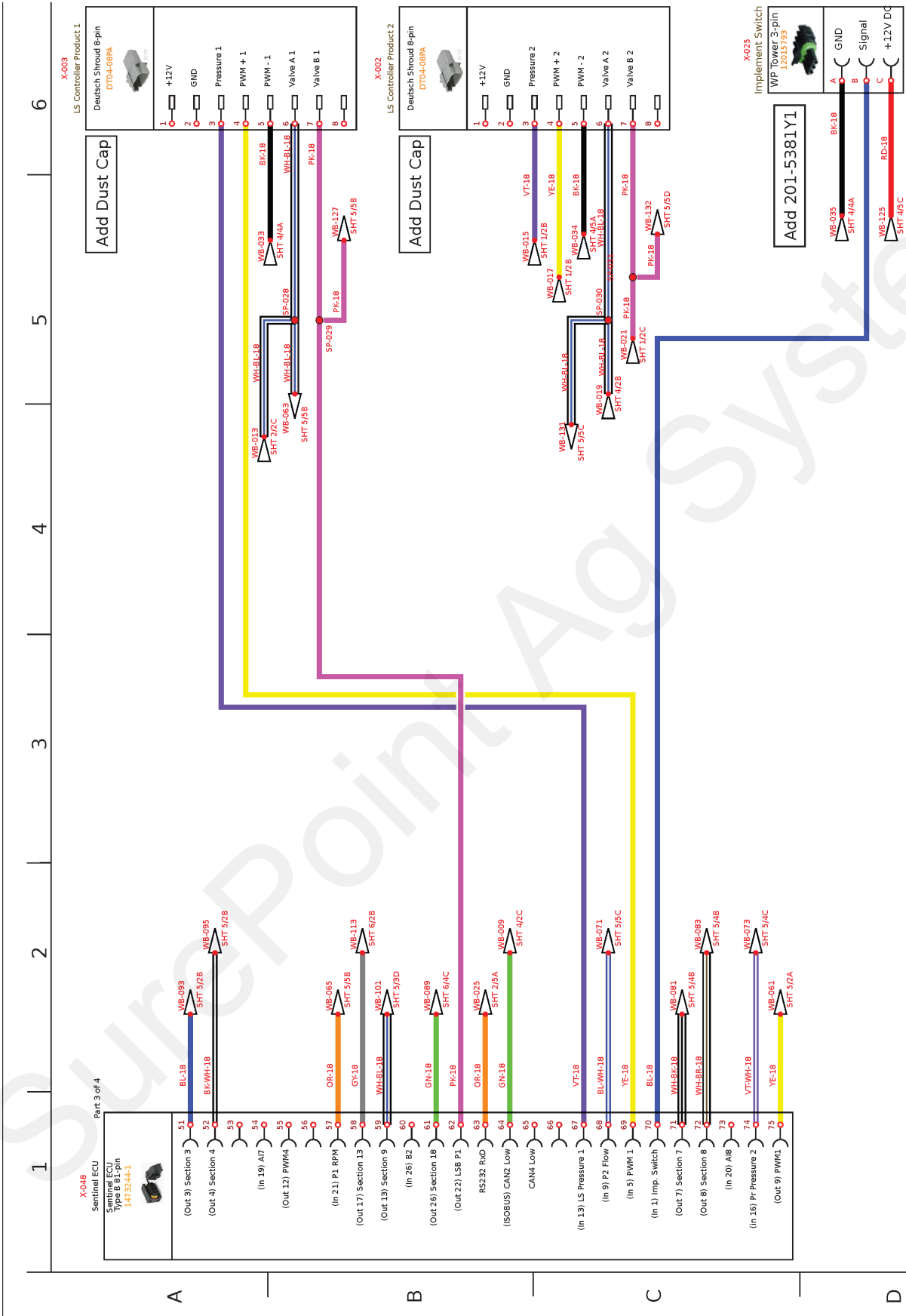

208-06-5022Y2 Sentinel Row Control and Flow Monitoring
ECU Harness– 2 Product 18 Sections Page 4 of 6



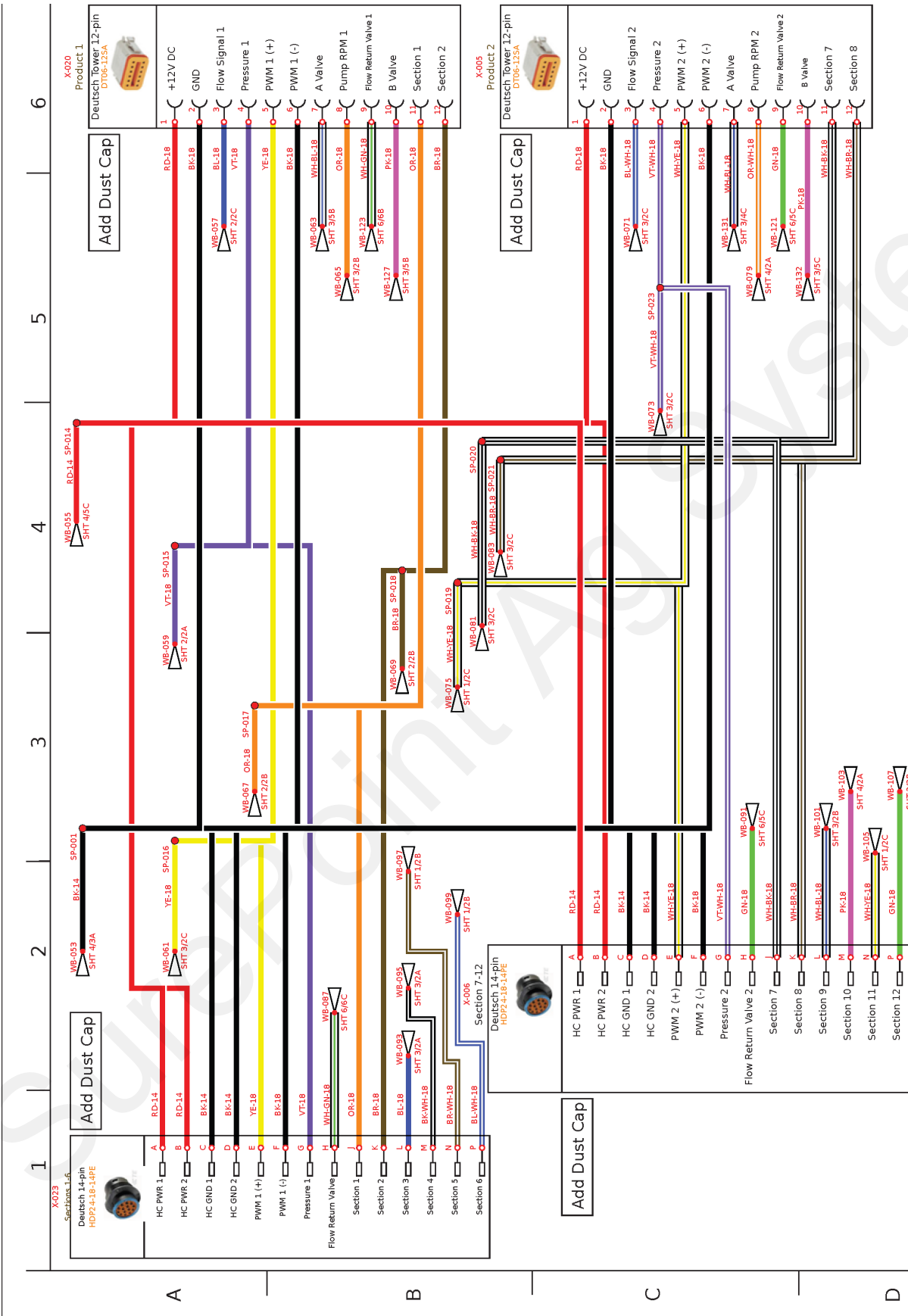

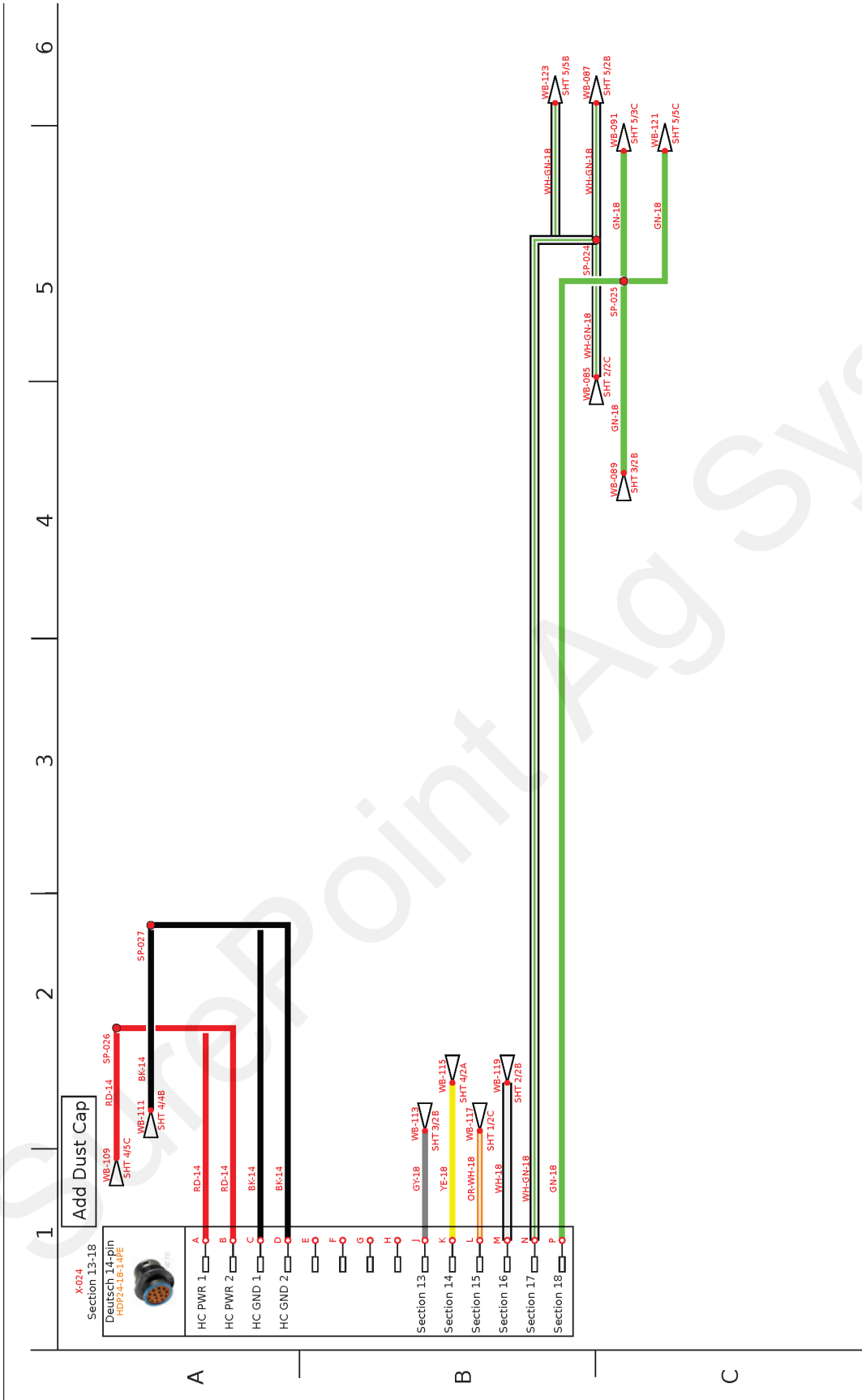

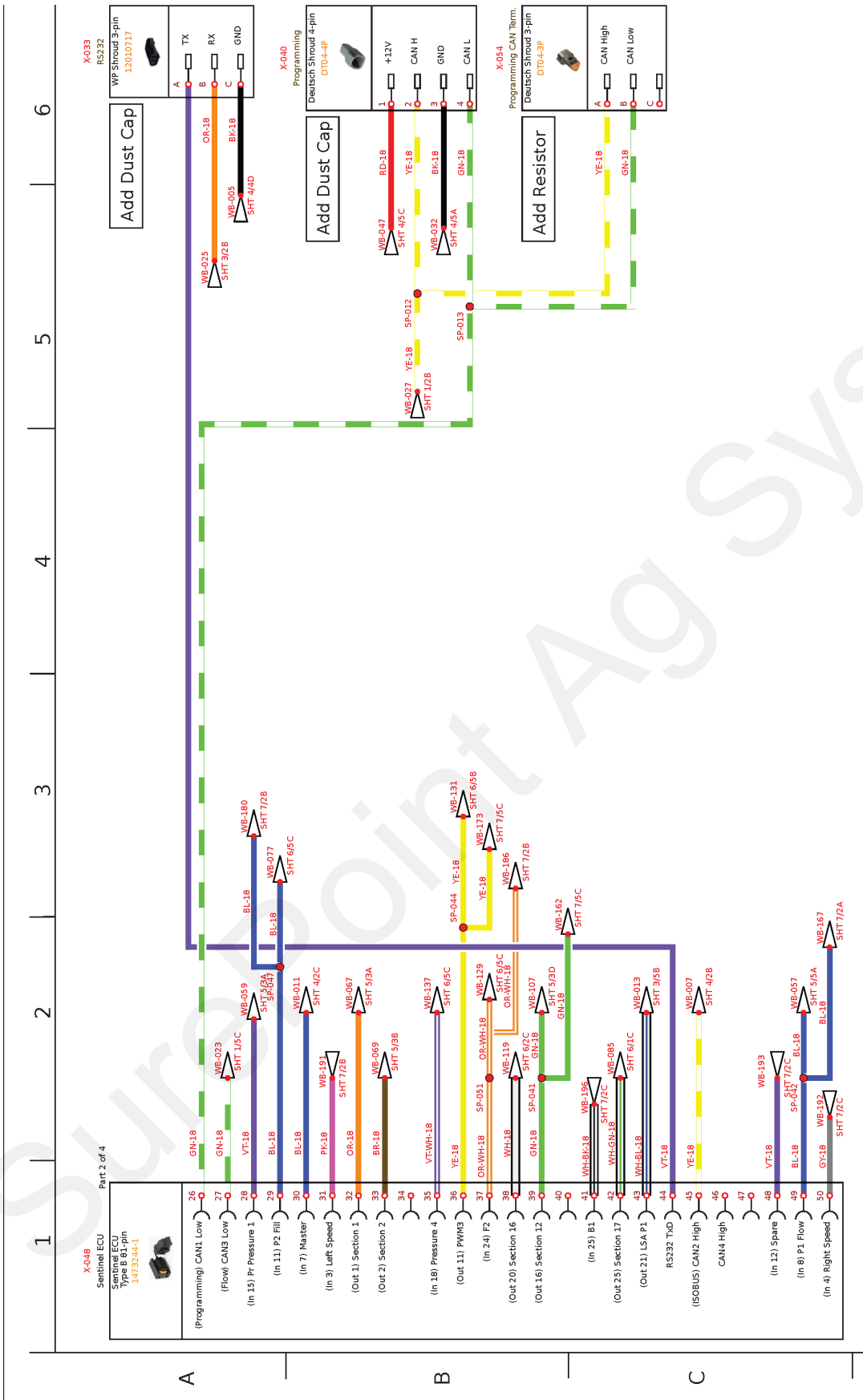

208-06-5993Y1 Sentinel Row Control and Flow Monitoring ECU
 Harness– 4 Product 18 Sections with Multi PWM Page 3 of 7

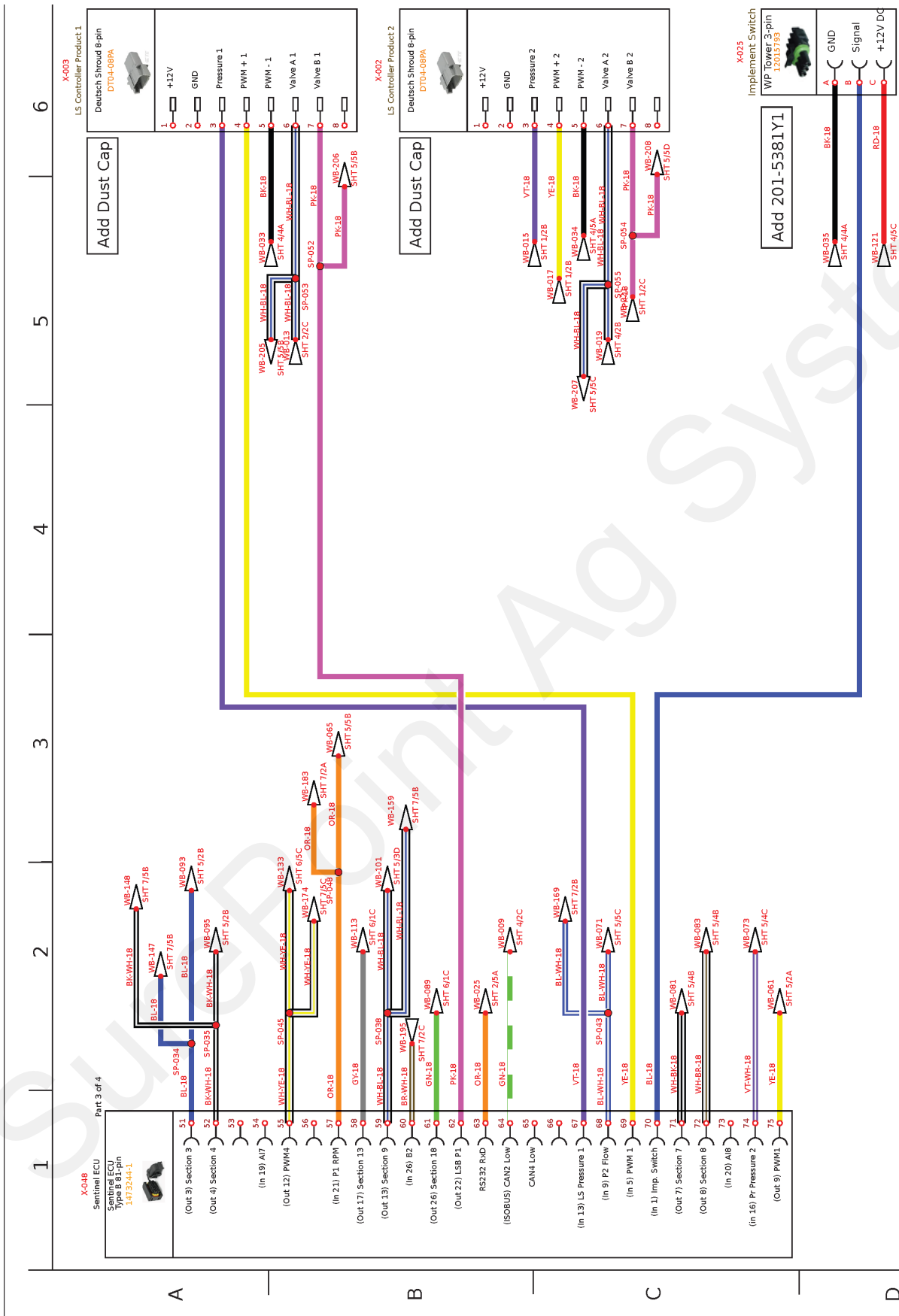

208-06-5993Y1 Sentinel Row Control and Flow Monitoring ECU
 Harness— 4 Product 18 Sections with Multi PWM Page 4 of 7

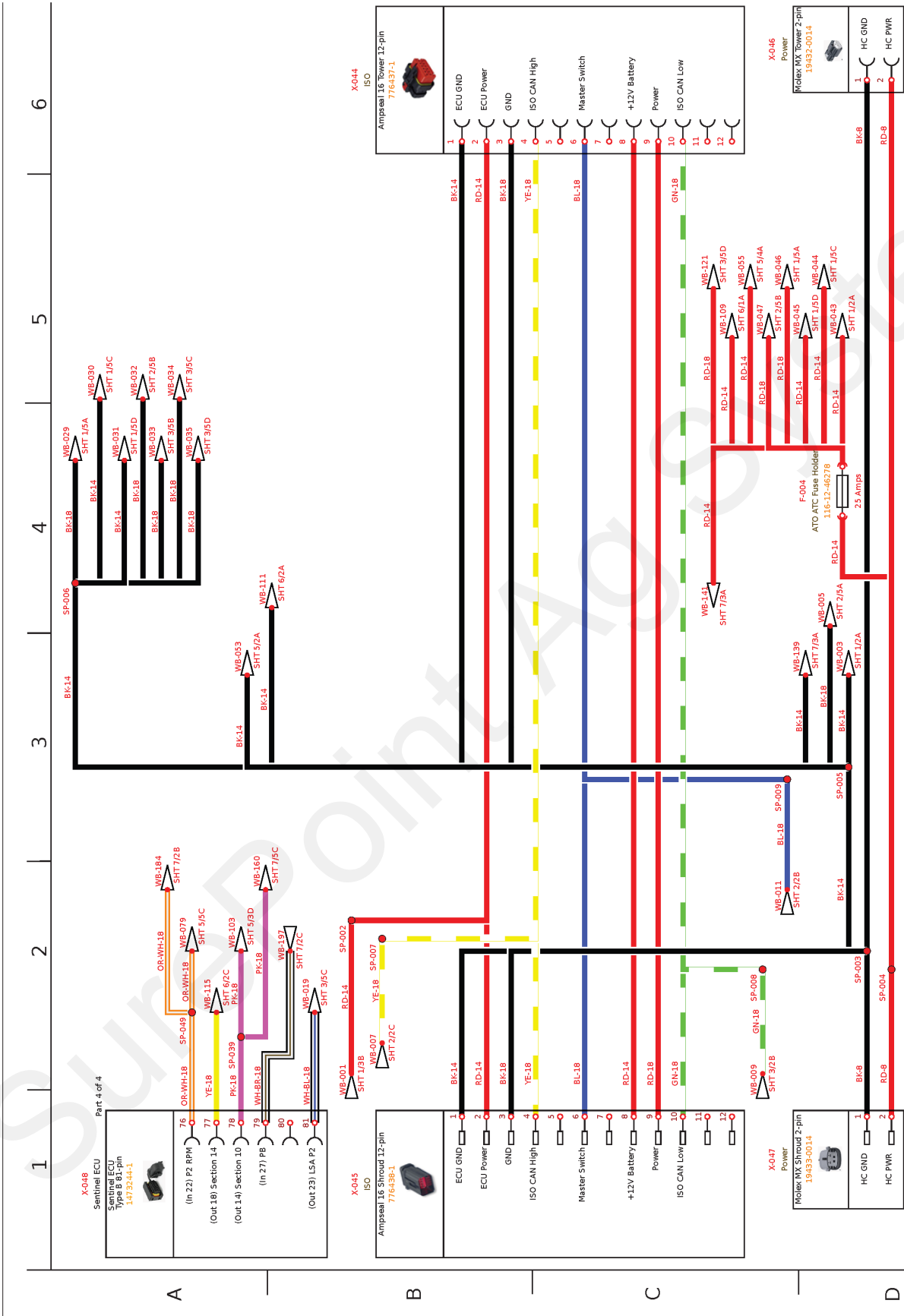

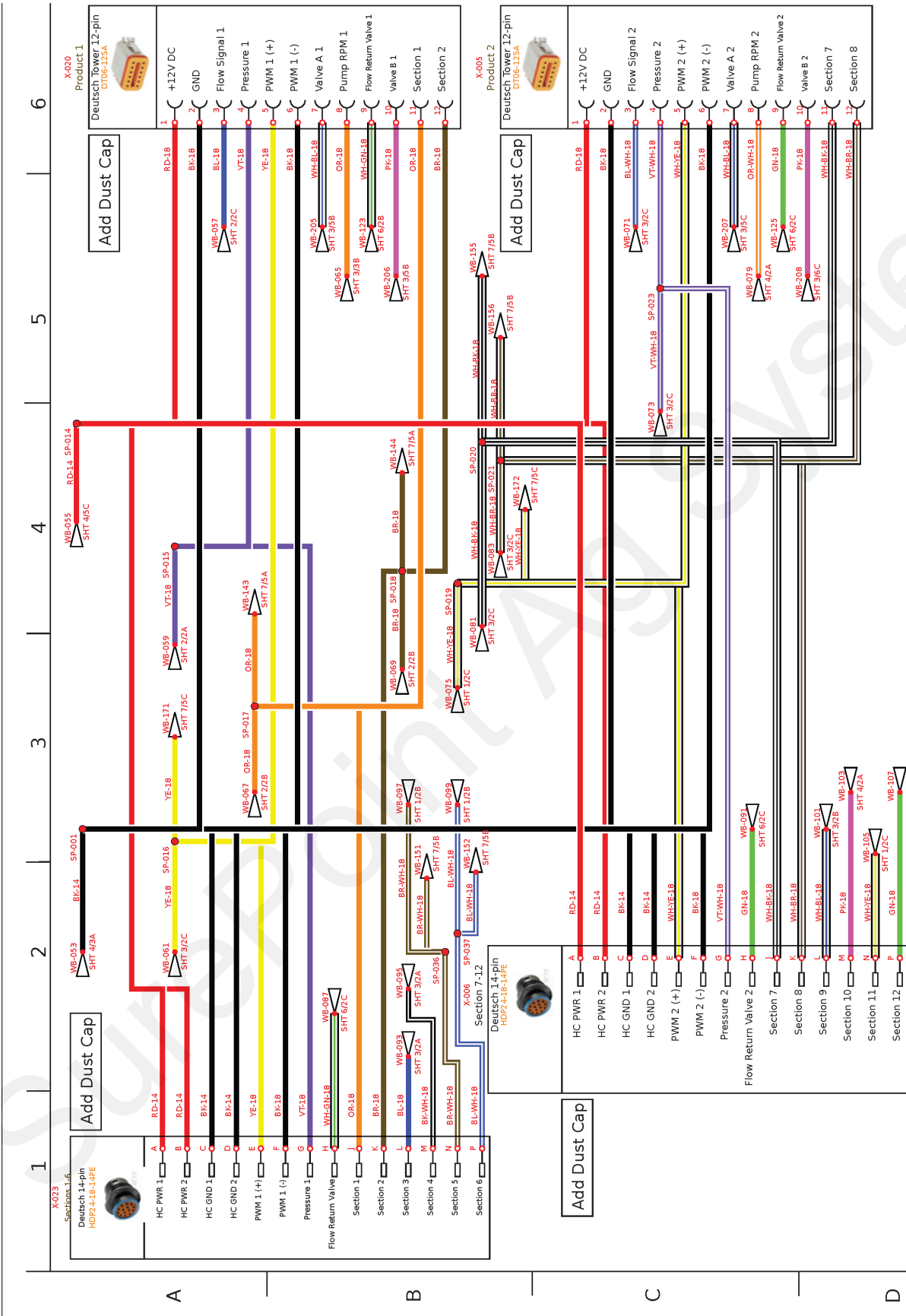

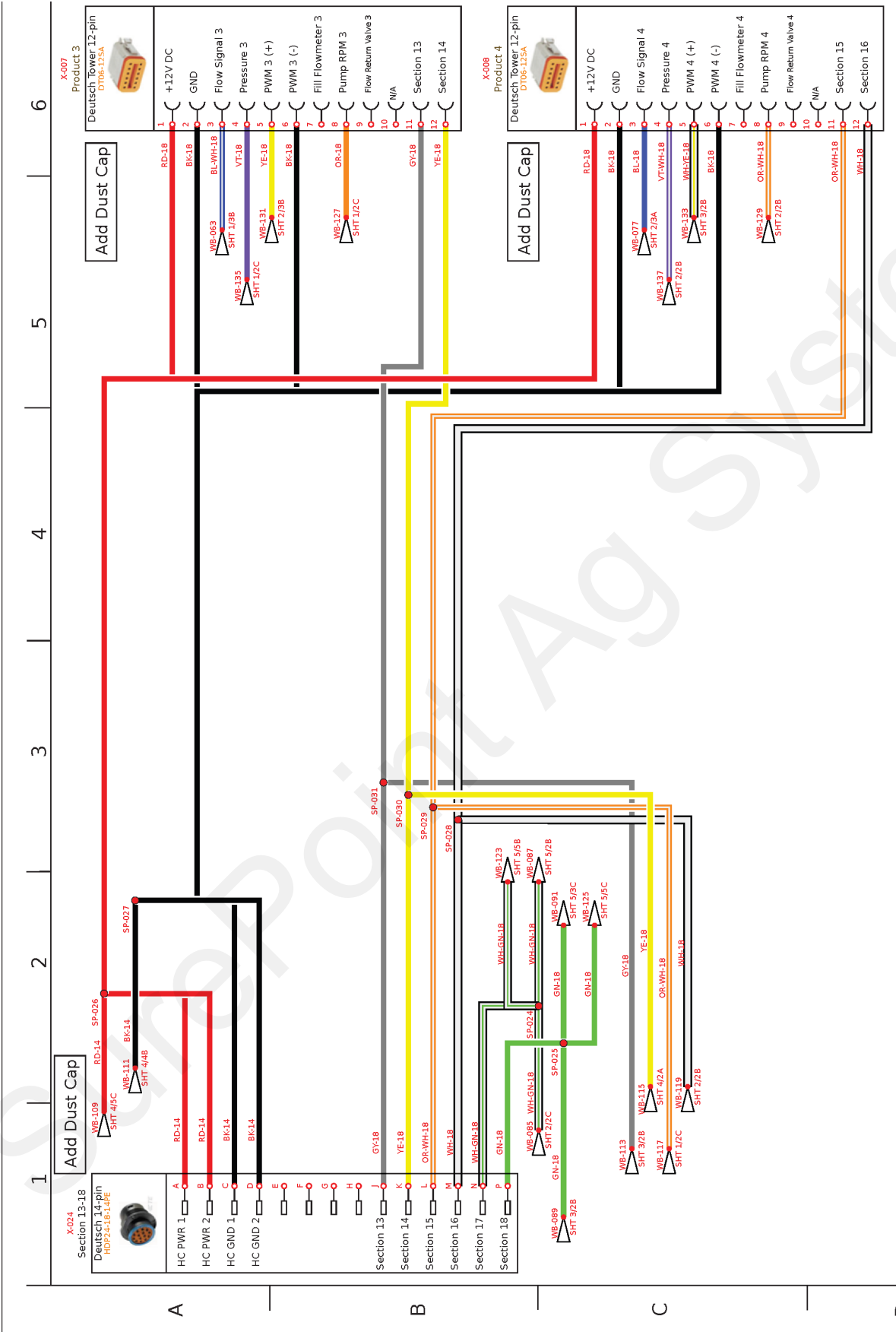

208-06-5993Y1 Sentinel Row Control and Flow Monitoring ECU
 Harness- 4 Product 18 Sections with Multi PWM Page 7 of 7

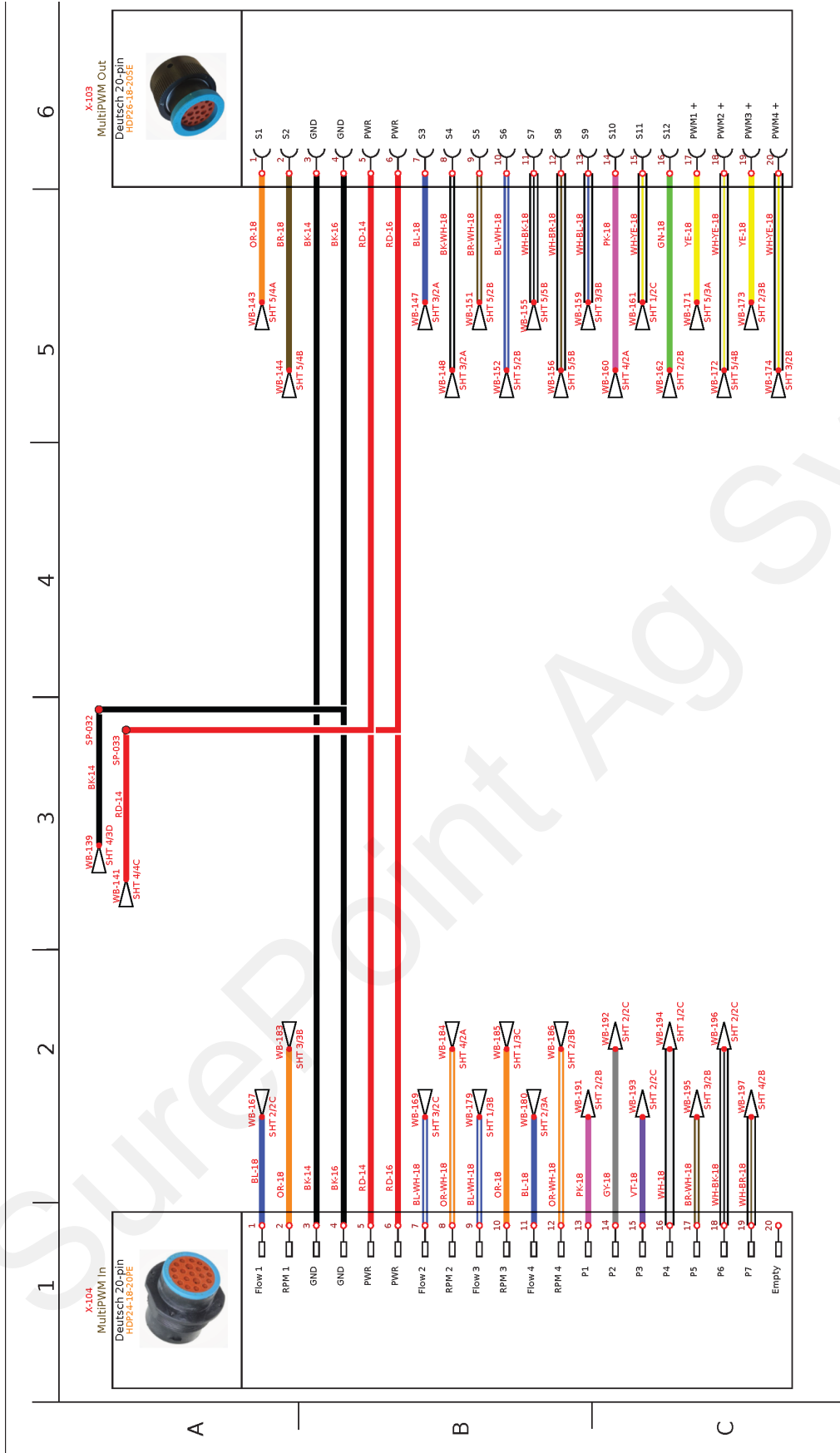

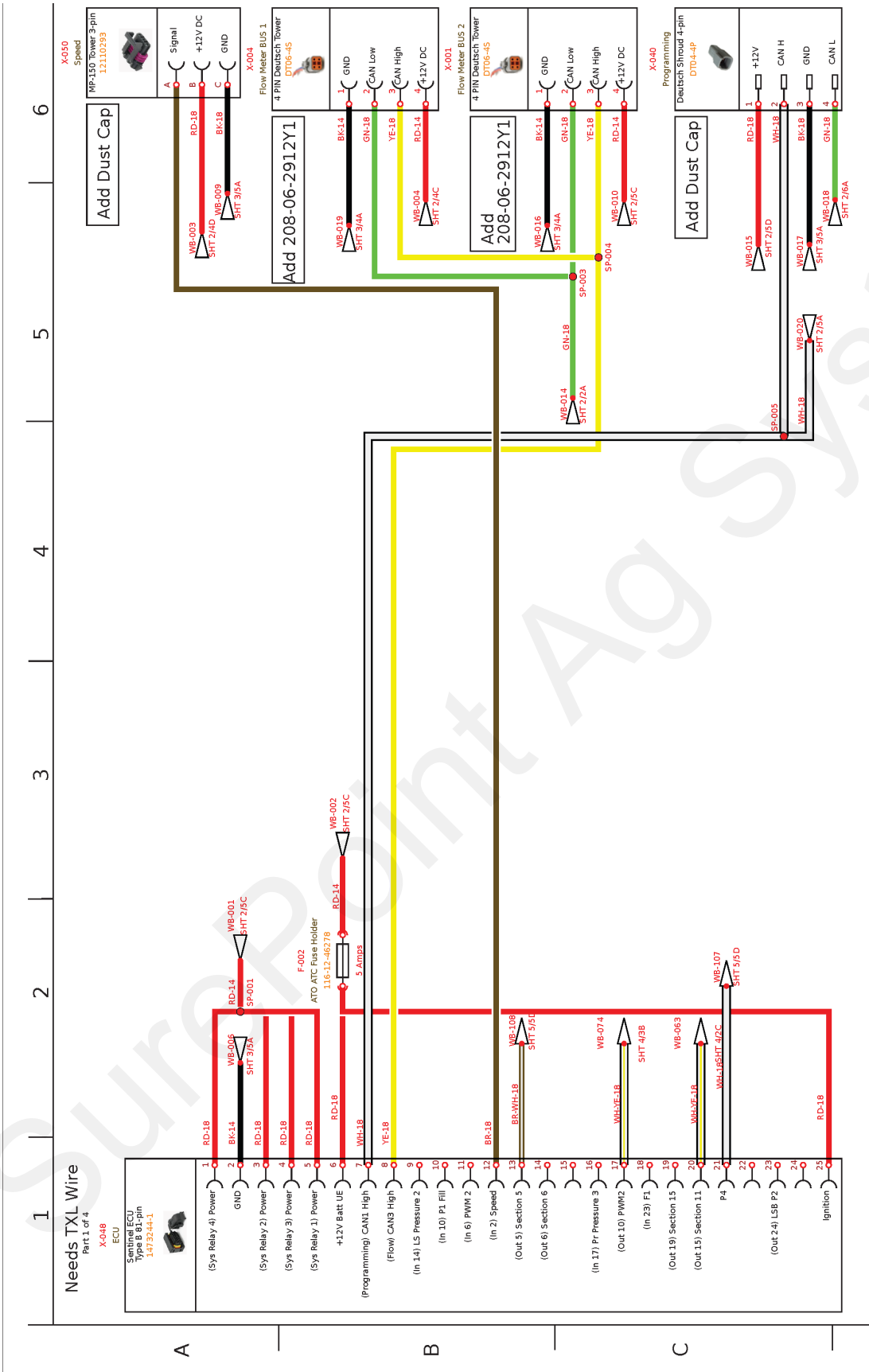

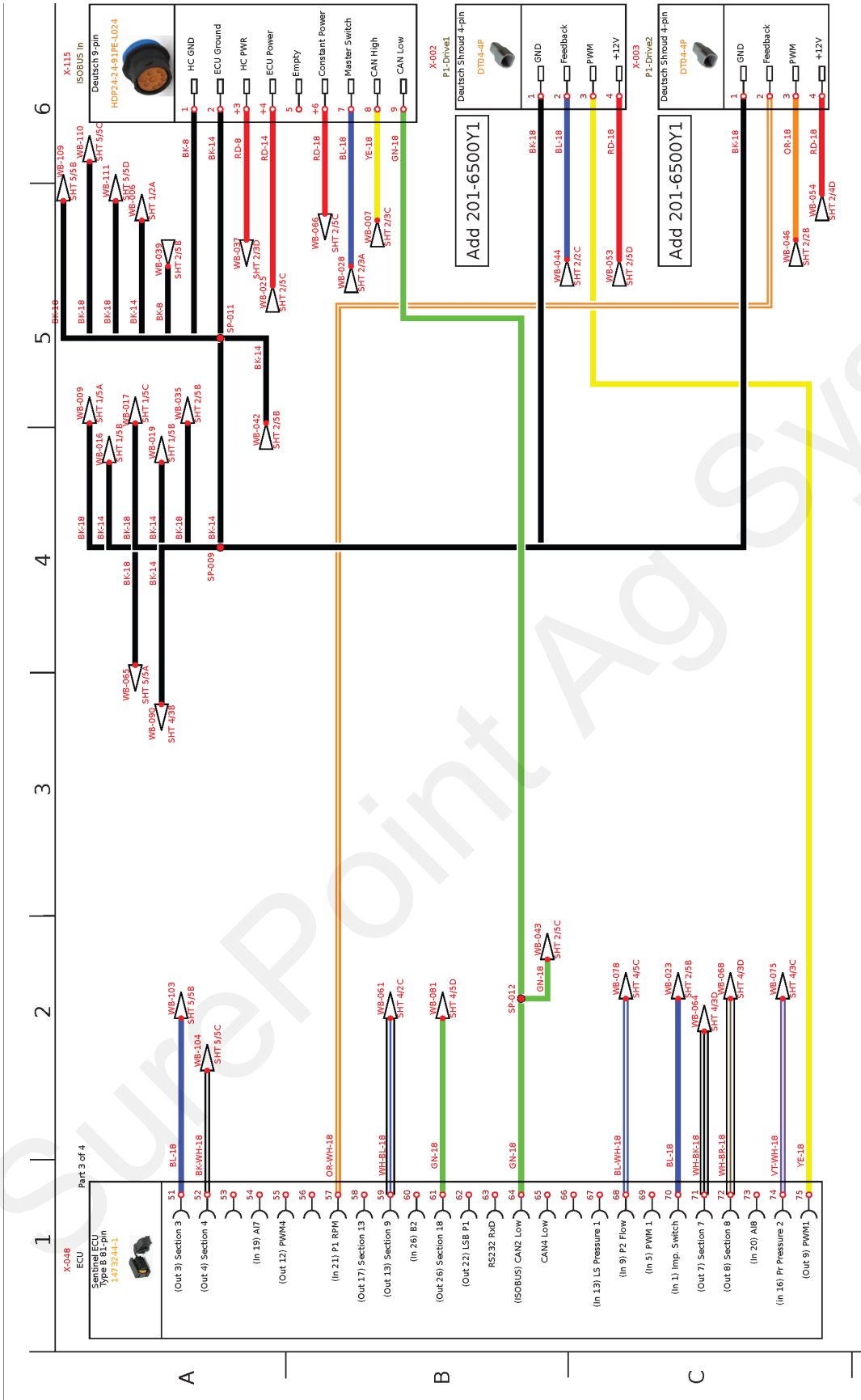

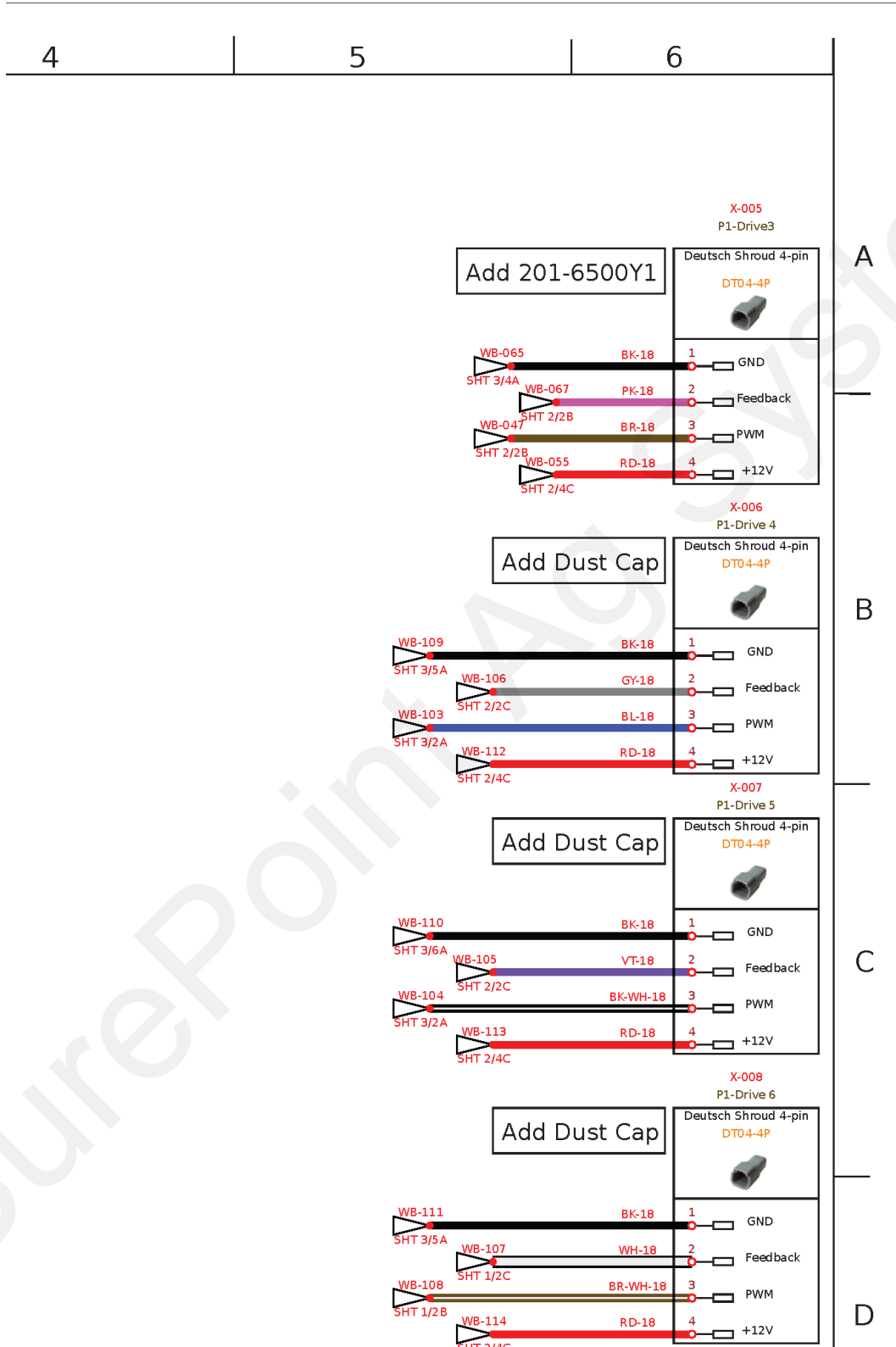

207-3492Y2
 12– pin Final Cable for Basic Dry Fertilizer System (pwm,
 meter rpm, aux rpm, bin level)

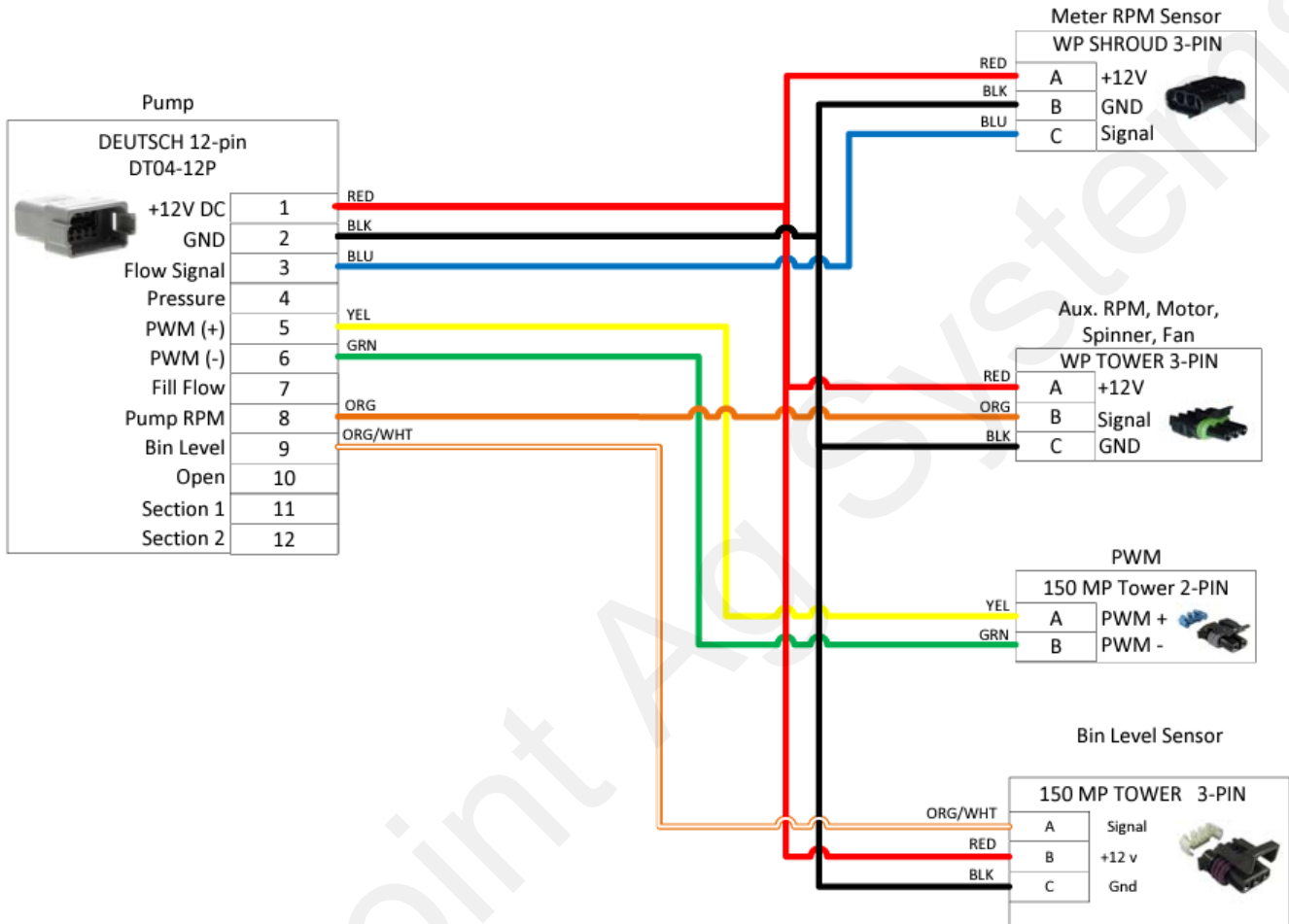

207-6500Y1
Sentinel Hyd. Drive Final Harness

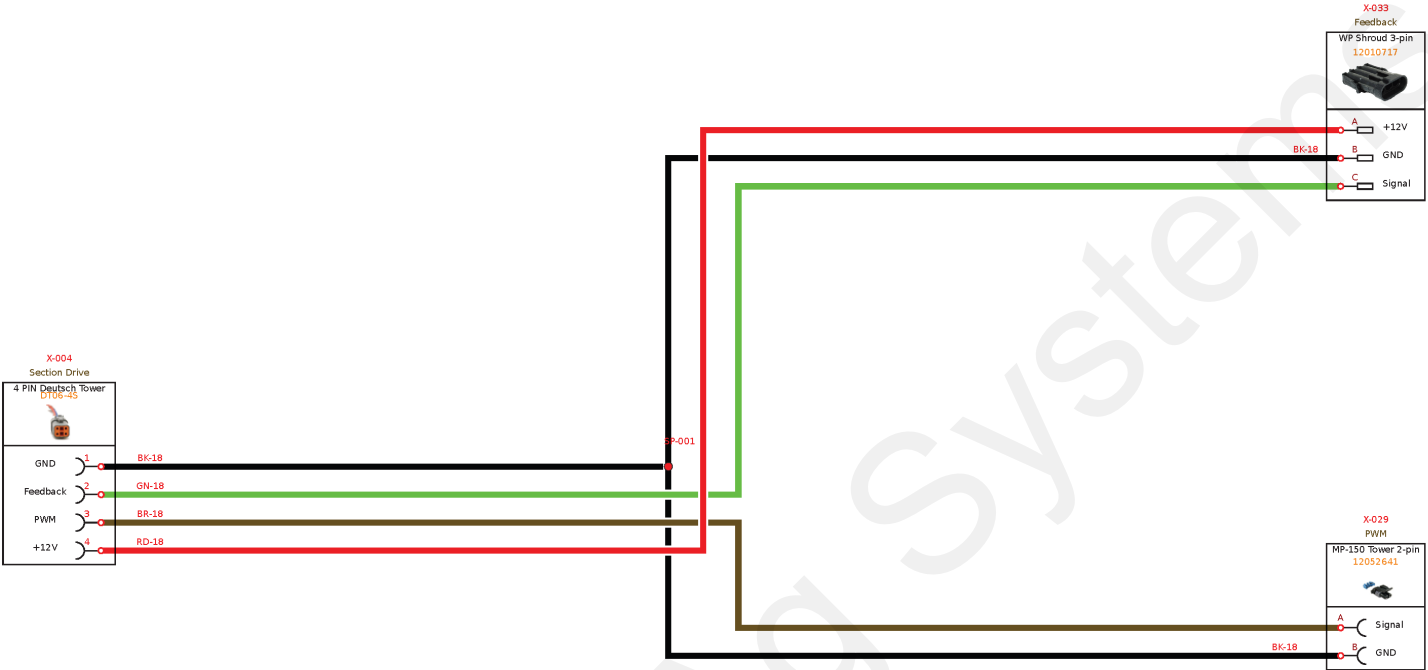

A Front ISO Extension will not be needed on all systems.

If there is a 12-pin ISO connector on the implement, the Sentinel ECU harness can be plugged in there.

If it is necessary to connect to the 9-pin ISO connector on the tractor, a Front ISO Extension will be needed.

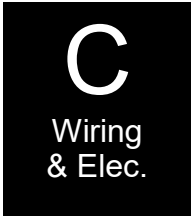

214-00-3553Y1 Thru 214-00-3557Y1

Front Extension Harness – (9-Pin ISO Connector @ 3-Pin Master Switch to 12-Pin Ampseal 16 ISO and 2-Pin Molex Power)

Wire 18AWG unless otherwise specified

+ Use this for troubleshooting harnessing, voltage, or communication issues. Some issues may need to be traced back to the 9-pin ISO connector. There is a fuse between the 9-pin ISO connector on the back of the tractor and the battery.

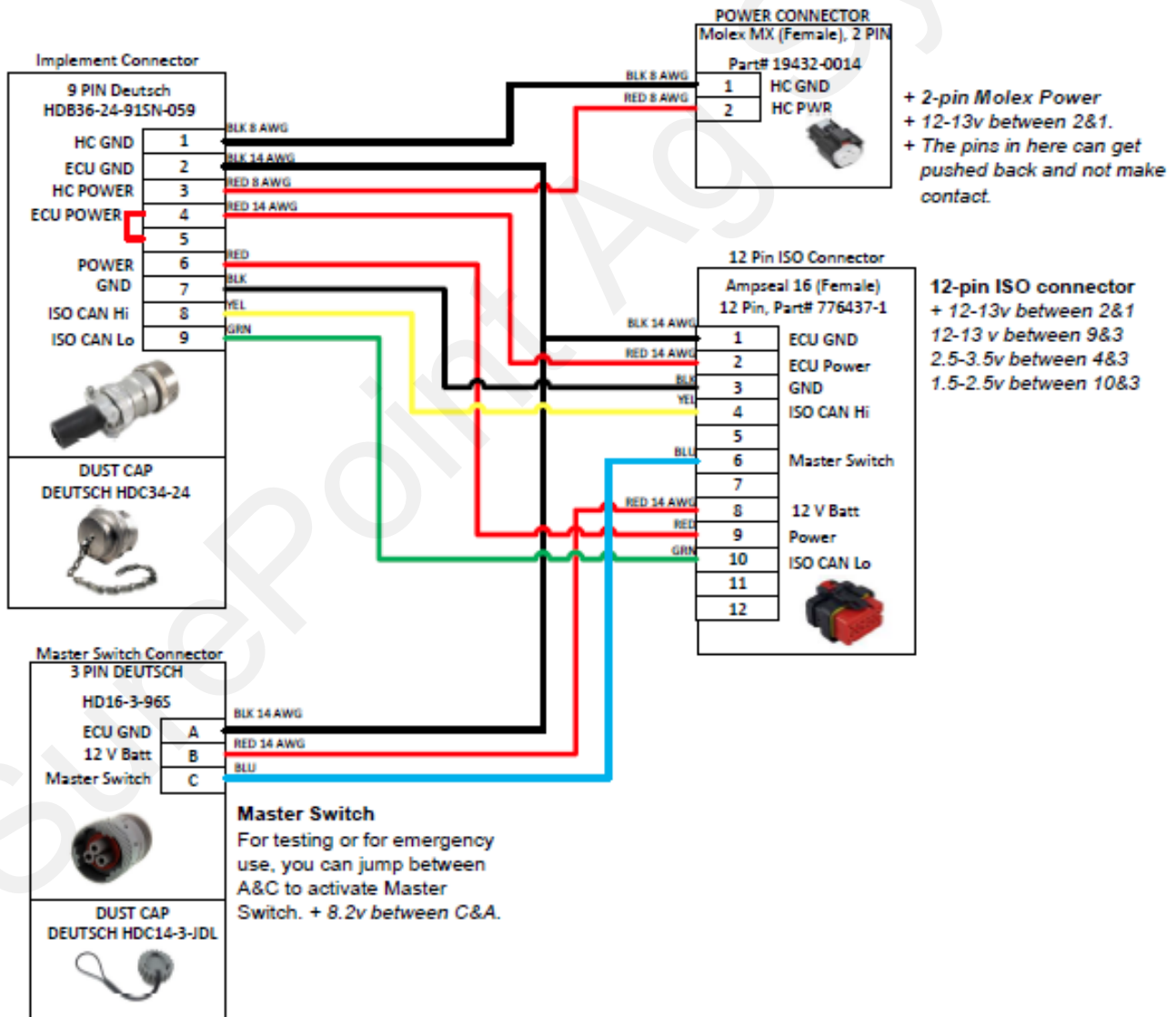

Setting Up a System With Sentinel Dry Control



226-01-3547Y1
Sentinel 2000 ISOBUS ECU

Typically will use one of the following Sentinel ECU Harnesses
For Dry Control

| | |
|---------------|---|
| 208-06-5022Y1 | Sentinel Row Control and Flow Monitoring ECU Harness- 2 products - 18 sections |
| 208-06-5993Y1 | Sentinel Row Control and Flow Monitoring ECU Harness - 4 products - 18 sections with MultiPWM |
| 208-06-4984Y2 | Sentinel Row Control and Flow Monitoring ECU Harness - 4 products - 18 sections |

Icons from Sentinel

D Setup & Operation



Sentinel Wheat "HOME" button - returns to the main run screen.



SETTINGS tools - set up products, devices, rows, sections



SETUP WIZARD



IMPLEMENT Setup - enter implement geometry



SPEED Setup - select speed source and see which speed sources are reporting speed.



HARDWARE - set up height switch, master switch, task control, Intellisec-tion



RATE Setup - set up rate mode, target rate, rate smoothing



SurePoint - see software version. Go to Auxiliary Settings screen.

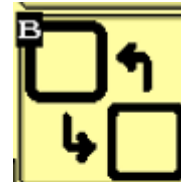

Next VT - when more than one display is in use, this moves the Sentinel to the next screen. (v.1.3.0)



Save to this VT - when more than one display is available. (v.1.3.0)



Nozzle Test - Run a test with a simulated speed and target rate. (v.1.3.0)



Catch Test - check and adjust flowmeter calibration. (v.1.3.0 and later)



Save Task Controller settings

Set-up and Configuration for Dry Control



Use the following pages for additional screenshots.









The following pages will guide you through the initial set-up and configuration of your Sentinel Rate Control system. Below is an overview of the steps necessary to fully configure the system before operation. Each subsequent page outlines the page features as well as the sequence of buttons used to navigate to that page from the HOME screen.

Basic Steps for Initial System Set-up for Dry Control

STEP

1. Press the **HOME** button 
2. Go to the settings page by touching the **SETTINGS** button 
3. On the settings page, specify the number of products being monitored (maximum of 4)
4. Configure each product by touching the **PRODUCT** button

| |
|-----------|
| Product 1 |
| 8 |
| 2 |
| 30.0 INCH |
| 20.0 FT |
5. Select Mode (*Dry*) and set up each product (sections, rows,...)
6. Press **MORE**, set up Rate (USER DEF), Smoothing (10%), other options for this setup.
7. When finished, use the BACK arrow to go back to the SETTINGS menu.
8. Set up the implement dimensions by touching the **IMPLEMENT** button. 
9. Choose a speed source by selecting the **SPEED** button. 
10. Select system control options (task control, lift switch, etc.) under **HARDWARE**. 
11. Select the Rate Mode (*USER DEF*) at **RATE SETUP**. 
12. From the Settings screen, touch the **NEXT** button. 
13. Setup settings for Rate Control - Control Speed, RPM Cal, Flow Cal, PWM Max and Min 

Common Buttons that you might use during setup.

Software Version and Auxiliary Settings Screens 

Customizable Toolbar and Totalizer Counters 

Nozzle Test - Simulated speed and rate test 

Catch Test - Verify and adjust flowmeter calibration 

Sentinel Setup and Configuration

Home Screen Navigation for Dry Control

D

Setup & Operation

Sentinel Home Screen for Dry Control.

Identifies this screen as showing Product 1.

If an implement height switch is plugged into the Sentinel harnessing, there is an arrow showing the current implement height status.

Target and Actual Rate shown. Green buttons indicate product is On. Multiple Products Ex. Shown

Operate, Setup, & Diagnostic tabs for Rate Control setup, operation, and troubleshooting diagnostics.

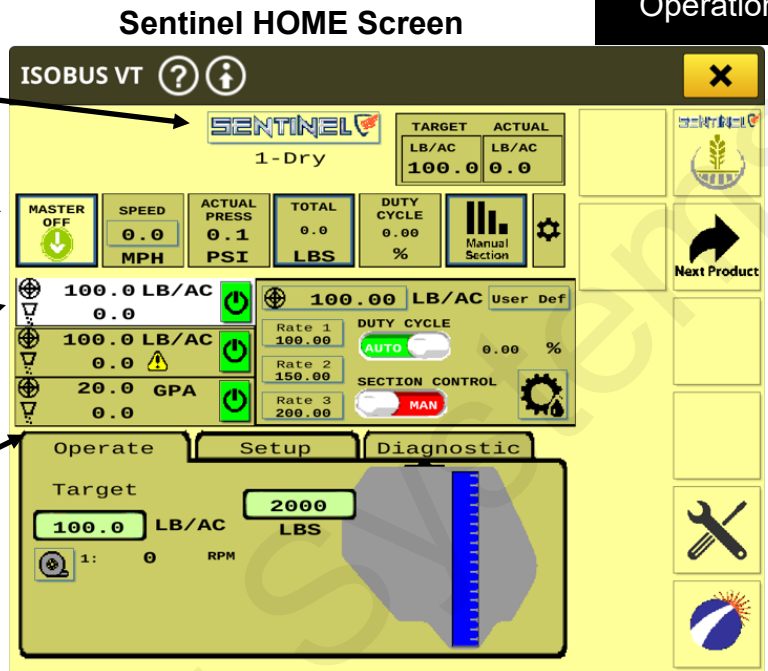

Wheat Button



The wheat button takes you to the Rate Control RUN SCREEN. This button appears on the top right side of the screen. Pressing it puts the Rate Control information in the center section.

Rate Control Information

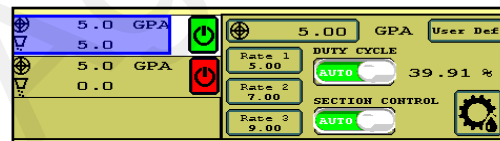

Customizable Toolbar (Screen Settings)

Touching this gear button will allow you to set up the icons on this **Customizable Toolbar** row of the screen. When you press this button you will see four rows of icons. The top row with white background shows what is on your screen now. To change an icon, press on that icon on the top row and then press on the icon you want there from the options below. **Click OK** to save.



Toggle between product screens by touching the **NEXT PRODUCT** button. Will appear below wheat button if using multiple products.



The **SETTINGS TOOLS** button will be used to access the system configuration pages for Product setup and to change individual product alarm, tolerance, and rate settings.

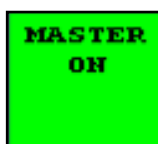

The **MASTER ON/OFF** button enables and disables the Sentinel system. *This must be **GREEN (MASTER ON)** for Sentinel to work.*

ARROW indicates implement position when using Implement Switch with Sentinel



SETUP for Dry Control - Setup for operations of the controller

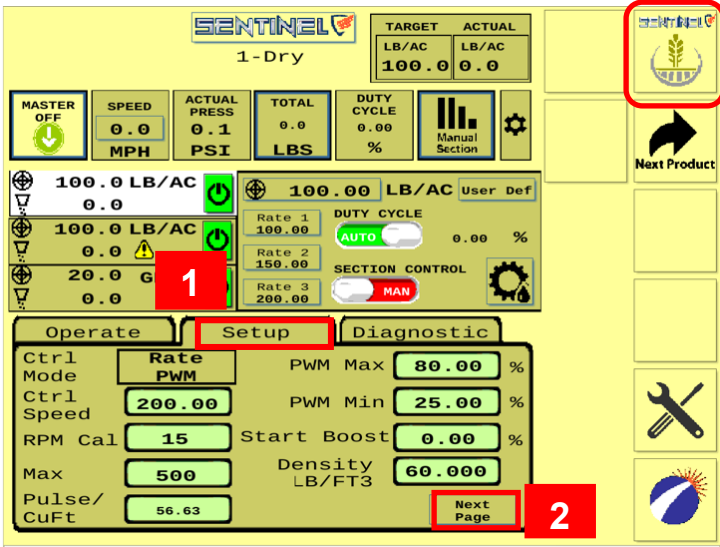

From Sentinel Home Screen

Disclaimer– These settings are highly variable depending on multiple factors that can affect your application rate. Verify with a catch test before planting.

1.) Press the center **SETUP** tab.

Start with the following settings. Adjust as needed.

Ctrl Mode - RATE PWM

Ctrl Speed - 50-200 for hydraulic motors. ISM & electric motors 500-1500.

Adjust as needed in the field. Increase the Ctrl Speed if the drive is slow to adjust. Decrease the Ctrl Speed if the drive fluctuates and will not lock on to the rate going across the field.

RPM Cal- Used for spinner/fan. Use cal number from spinner/fan sensor. Leave at 15 if not using a spinner/fan sensor.

Max RPM - 500

Pulse/ CuFt - How many revs it takes to get a cuft of product. Highly variable, utilize a catch test to calibrate this setting (see page 45.)

PWM Max - 80 to 100 (can be set lower to limit motor speed)

PWM Min - 25 for most hydraulic valves adjust if lower duty cycle is needed to achieve rate.

Start Boost - When start boost is set to 0, the PWM will return to the last percentage. Can be set slightly higher than normal PWM Duty Cycle for a startup boost.

Density LB/Ft3 - Density of the product per cubic ft. **Set before you utilize the catch test.**

2.) **Next Page –**

Fan RPM Req– Sentinel 1.5.0 doesn't support this feature. Don't Check

Enable Fan 2– Sentinel 1.5.0 doesn't support this feature. Don't Check

Alarm %- When you want to be alarmed when tank is low

Tank Capacity– Amount of Lbs the tank holds

Tank Level Source– CALC. Sentinel 1.5.0 doesn't support scales.

Inv Level Input– Sentinel 1.5.0 doesn't support this. Don't check

Back Button- to return to main setup page

3.)**DIAGNOSTIC TAB -** Observe the system parameters during operation. Green means condition met to apply, Red means not met, gray means it is ignored.

Top Row– 1. Master On and Product Enabled (power button by individual product) 2.Implement Down 3. Task Control/Section Control(at least one section being told to apply by task control) 4. Tractor Speed above 0(simulated speed will meet this requirement)

Bottom Row– 1. Target Rate is above 0, 2. Fan is at minimum application speed (not used for Sentinel 1.5.0)

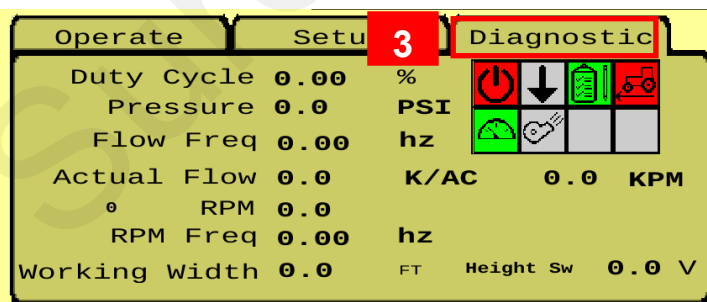
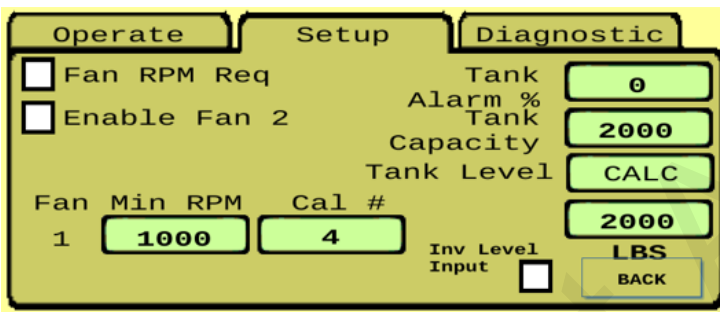

Operate Tab for Dry Control - Target, Spacing, and Tank Levels

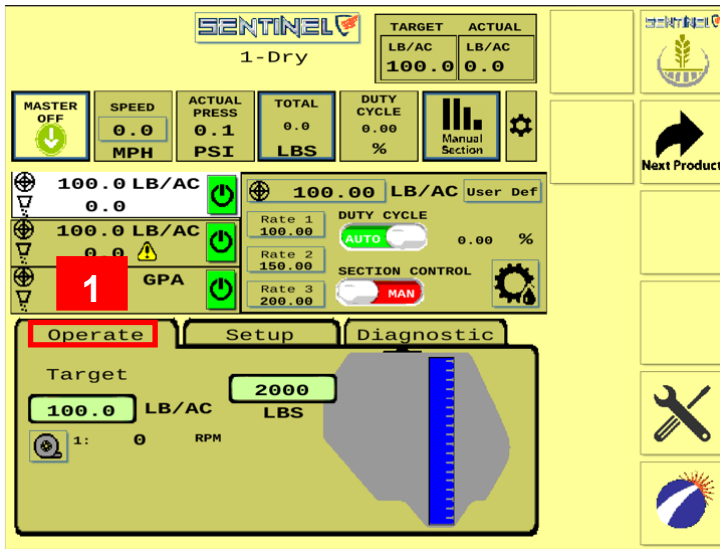

Operate Tab

- 1.) Your operate tab will show you target rate. Seed Spacing and Tank Level.
- 2.) **LB/Acre**– This shows the LBS per acre.
- 3.) **Fan RPM**– This will remain at zero for 1.5.0
- 4.) **Remaining Tank Volume**– This is how many pounds of product you have remaining in your tank.
- 5.) **Tank Volume Gauge**– This will show an amount of product left. To refill the tank push the gauge.
- 6.) **Tank Full**– Push to refill tank to full capacity

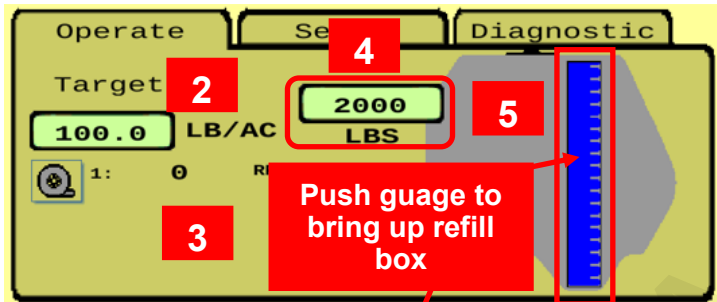

SETUP for Dry Control - Settings - Product - Mode

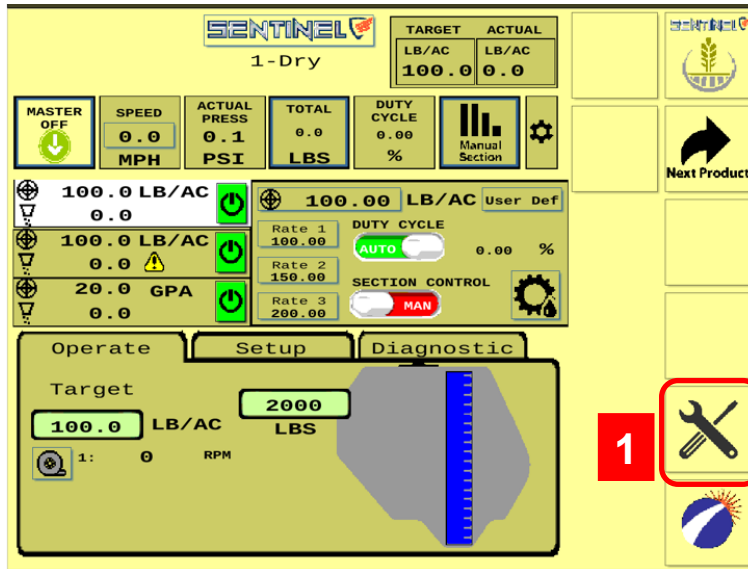

1.) Press the **SETTINGS** Tools button to go to the System Configuration screens.

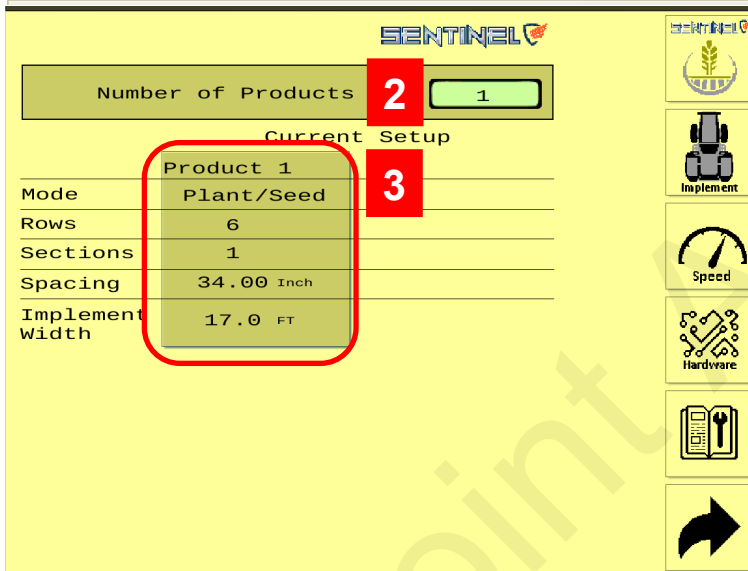

2.) Enter the **number of products** that will be monitored or controlled with the Sentinel.

3.) Press the big **Product 1** box.

(If the system has two products, there will be a Product 2 box to the right of Product 1. Set up Product 2 in a similar fashion to what is shown for Product 1.)

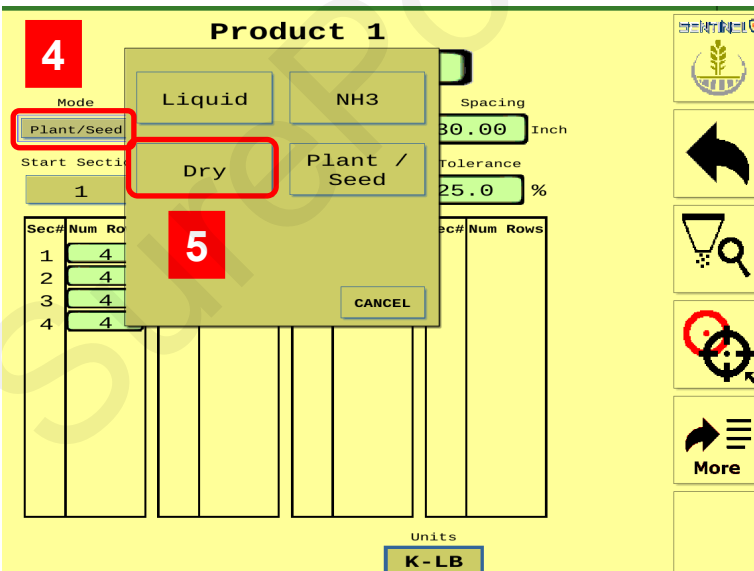

4.) Press the box under **"Mode"**.

5.) Select **"Dry"** to use the Sentinel for Dry Control.

SETUP for Dry Control - Product Setup - Rate Mode Setup -

To access Setup Screen press

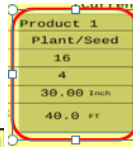
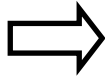

Product 1
1-Dry

Mode: 1-Dry

Total Rows: 48 (7) Sections: 3 (8) Spacing: 10.00 Inch (9)

DryRateCo: 1 (6) Start Section: 1 (10) Implement Width: 40.0 FT (11) Tolerance: 25.0 % (12)

| Sec# | Num Rows | Sec# | Num Rows | Sec# | Num Rows | Sec# | Num Rows |
|------|----------|------|----------|------|----------|------|----------|
| 1 | 16 (13) | | | | | | |
| 2 | 16 | | | | | | |
| 3 | 16 | | | | | | |

Units: LBS (14a)

More (14b)

6.) Mode– Choose **Dry**

7.) Enter the number of **Rows** for this product.

8.) Enter the number of **Sections** for this product.

9.) Enter the row spacing in **INCHES**.

10.) Press **Start Section** to access the section valve options tab.

10a.) Choose section valve type. Wired, CAN, or None-

10b.) To invert section valve outputs check here. Needed on some implements with clutch drives depending on how power is supplied.

11.) Verify **Implement Width** in FT.

12.) **Tolerance** - Do not adjust for Dry. Only used in liquid application

13.) Verify the number of rows in each section.

14a.) Choose between **Lbs.** or **Kg**.

14b.) Press **More** to go to the next screen.

15.) See below: **Rate Mode** - For rate control, set this to **Rx** (for prescriptions) or to **User Def** to enter preset rates. Enter the main target rate in **Rate**.

16.) **Rate Smooth** - Start with 10%. If the actual Rate at any time is within this % of the Target Rate, the display will show the Actual Rate as being equal to the Target Rate.

Row Smooth - 10% Effects the smoothing applied to the numbers sent to the as-applied map.

17.) You can enter up to 3 user-defined rates.

18.) **Rate for Outside Rows** is typically "X 1.0".

Some applications may be "X 0.5" (half-rate) or "X 1.5" (rate and a half) for outside rows.

19.) **Control Integral** - 0.10

20.) Start Section– This is the same as step 10 above. Use ISM isn't used in dry.

21.) **Sect PWM**– Check for multiple section drivers utilizing hydraulic PWM valves.

22.) Press the **Back Arrow** when finished with this screen.

Product 1
1-Liquid

Mode: 1-Liquid

Plant/Seed: 6 (10) Sections: 1 Spacing: 34.00 Inch

Start Section: 1 (10) Implement Width: 17.0 FT Tolerance: 25.0 %

Enter what wired Section this product starts on or check "CAN" or "Unused" if wired section outputs aren't needed.

1 (10a)

Invert Section Outputs (10b)

Sect Type: Wired

Units: K-LB

More

Product 1
1-Dry

Rate Mode: User Def (15) Rate: 100.00 (16) Rate Smooth: 10 % (checked)

Avg: Rx (15) Totals: Row Smooth: 10 % (checked)

User Defined Manual Rates: 100.00 (17) 150.00 200.00

Outside Row Rates: First: X 1.0 (18) Last: X 1.0

Control Integral (Ki): 0.10 (19)

Start Section: 1 (20) Use ISM: Sect PWM: (21)

Enter what wired Section this product starts on or check "CAN" or "Unused" if wired section outputs aren't needed.

1 (21) Invert Section Outputs

Sect Type: Wired

More (22)

SETUP for Dry Control - Implement - Speed - Hardware

To access from home screen



24.) Press **Implement** to enter and verify the Implement geometry. These are very critical for correct task control functions.

A = distance from Hitch to implement pivot (axle)
 B = implement offset (left or right)
 C = distance from Implement pivot (axle) to application point
 (This combines with the geometry set up in the controller for the position of the GPS in relation to the hitch)
 Press the Back Arrow when finished.

25.) On the right side, Press **Speed**.

26.) Press the top box to select the Speed Source. This is typically Ground Speed.

26.B) Speed Smoothing— don't change unless advised to by SurePoint Ag

26C.) Select speed source that matches tractor speed.

26

27.) On the right side, press **Hardware**.

28.) **Use Master Switch** - check this box if a dedicated Master Switch (Foot Switch) is plugged into Sentinel.

29.) **Use Height Switch** - Check this only if the Sentinel has a dedicated height switch.

30.) **Setup** - to set up a height sensor or to change orientation of switch.

31.) **Enable Task Control** - normally used for Rate Control. Also, must activate Task Control on display.

32.) **Enable IntelliSection Technology** - Not used for dry control.



SETUP for Global Settings

To access press



SENTINEL

Number of Products

Current Setup

| Product 1 | |
|-----------------|------------|
| Mode | Plant/Seed |
| Rows | 16 |
| Sections | 4 |
| Spacing | 30.00 Inch |
| Implement Width | 40.0 FT |

33

33.) From products from screen. Press forward arrow to Global Setting Page.

Global Settings 1/2

34.) When checked, the Auto Scan feature will scan through the product pages and/or rows on the HOME screen. You can change the length of time it stays on each page or row before advancing.

35.) On Gen 4 and newer Deere displays the Console A/M will mirror section control from the display. This allows you to turn on and off all products with section control. **Do not use on non-Deere displays**

Global Settings 1/2 **SENTINEL**

34

Auto SCAN Pages SEC

Auto SCAN Rows SEC

Console Sect A/M 35

Product IO Diag

36

45

Next VT

36.) Product IO Diag– Used for identifying input/output of ECU.

Global Settings 2/2

37.) Auto Hide Alarms (if checked) sets how long full-page alarms are displayed before they go away.

38.) Disable Alarms - Check this to turn off alarms. May want to do this for testing or troubleshooting.

39.) Alarm Time - how long a row must be outside of the specified tolerance before the alarm sounds.

40.) Re Alarm Interval - The time before the Alarm alarms again after being acknowledged. If the issue that triggered the alarm is not resolved, it will keep alarming at this interval until resolved (if the box is checked).

Global Settings 2/2 **SENTINEL**

Auto Hide Alarms SEC 37

Disable Alarms 38

Alarm Time SEC 39

Re Alarm Interval SEC 40

Area/Press/Implement Units 41

Temperature Units 42

43
Store Obj Pool

44
Delete Obj Pool

45
Next VT

41.) Press to change units to Imperial or Metric

42.) Choose Temp. in Deg F or Deg C

43.) Store Object Pool - Stores the current ISOBUS layout on the VT.

44.) Delete Object Pool - Deletes the current object pool on the VT and forces the monitor to regenerate the display when it is rebooted.

45.) Next VT - press to push Sentinel to another virtual terminal. This may be necessary if there is more than one monitor or display in the cab.

Sentinel Version and Auxiliary Settings Screen

To Access Press SurePoint Logo From Any Page



2 SurePoint Ag Systems

Sentinel ECU Version:
V.1.5.0

Sentinel ECU Serial #
52
OU81200000000000000000BR549
A00880005D40000A
0004D0116E04A004

ECU Instance:
1

1 SurePoint icon

Auxiliary Settings Screen
WARNING: Do not change without consulting with SurePoint Ag!

| | |
|--------------------------|-------------------------------------|
| Rate/Target At Boom | <input checked="" type="checkbox"/> |
| Rate/Target At Bin | <input type="checkbox"/> |
| Rate/Target At Section | <input checked="" type="checkbox"/> |
| Rate/Target At Row | <input type="checkbox"/> |
| Bin Enabled | <input checked="" type="checkbox"/> |
| Register As Device Class | Auto |
| Use Prod2 As Fan Control | <input type="checkbox"/> |
| Use LS Conn For Press | <input type="checkbox"/> |
| Simulate Flow (Demo) | <input type="checkbox"/> |
| Turn Compensation X Axis | <input type="checkbox"/> |
| Bus Update Interval | 1000 MSEC |
| Enable VT4 | <input type="checkbox"/> |

4 Bus Update Interval

5 REBOOT CONTROLLER

3 Starburst icon

- 1.) SurePoint Icon - press for version information
- 2.) Press hidden Starburst for Auxiliary Settings Screen.

Do not use this screen without authorization.

Auxiliary Settings Screen-

Typical setup for implements to the left.

3.) Enable VT4– On Gen 4 and newer Deere displays checking this allows for the use of split screen setup on the display.

4.) Bus Update Interval - Use this to slow down ISOBUS traffic if the BUS load is too high. Change only after talking to a SurePoint representative.

5.) Reboot Controller– Allows for a reboot without a key cycle. Can be used to restart controller if some functions are lost due to low voltage on tractor startup.

Only make changes on this page after speaking to a SurePoint Ag Support Specialist.

Auxiliary Settings for most displays shown above.

For JD 2630, use below:

| | |
|------------------------|-------------------------------------|
| Rate/Target At Boom | <input type="checkbox"/> |
| Rate/Target At Bin | <input checked="" type="checkbox"/> |
| Rate/Target At Section | <input type="checkbox"/> |
| Rate/Target At Row | <input type="checkbox"/> |
| Bin Enabled | <input checked="" type="checkbox"/> |

For Ag Leader, use below:

| | |
|------------------------|-------------------------------------|
| Rate/Target At Boom | <input checked="" type="checkbox"/> |
| Rate/Target At Bin | <input type="checkbox"/> |
| Rate/Target At Section | <input type="checkbox"/> |
| Rate/Target At Row | <input type="checkbox"/> |
| Bin Enabled | <input checked="" type="checkbox"/> |

Pro 1200: Register as Device Class - Sprayer

Customizable Toolbar & Totalizer Counters - Acres - Hours - Gallons



Sentinel has 3 totalizer counters to keep track of acres, hours, and pounds.

Any of these may be set up on the Customizable Toolbar near the top of the Product Run Screen. If these are not on the Customizable Toolbar, the values may still be seen by pressing the *Reset Totals* button on the Rate Setup screen. The items may be individually reset to 0 by pressing the Reset Total button for that item, or the totals may be left unchanged by returning to the Run Screen without resetting the values.

Customizable Toolbar

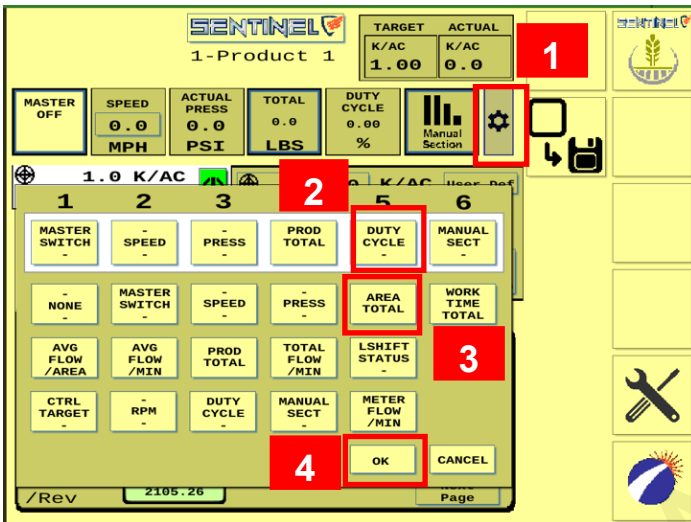

Rate Setup Screen

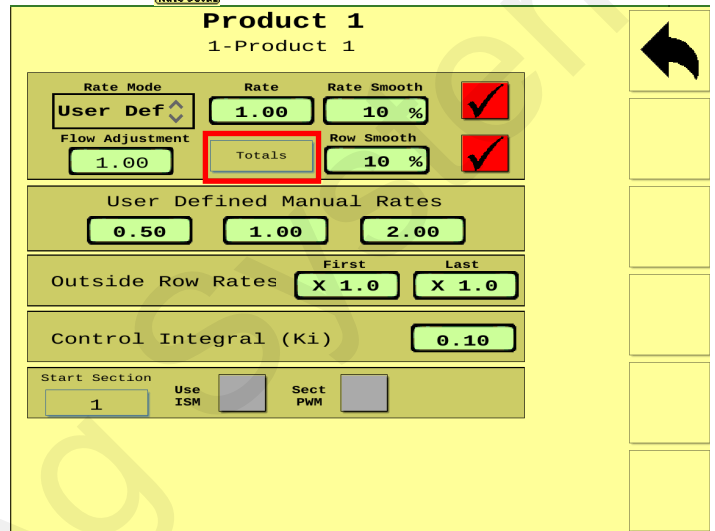

To edit Customizable toolbar-

- 1.) Press Gear
- 2.) Choose which button to change in the white bar.
- 3.) Choose which button to want to swap it with below.
- 4.) Hit OK

Item will change out in white box as shown below. Repeat the step above with any other changes you want to make in the customizable toolbar.

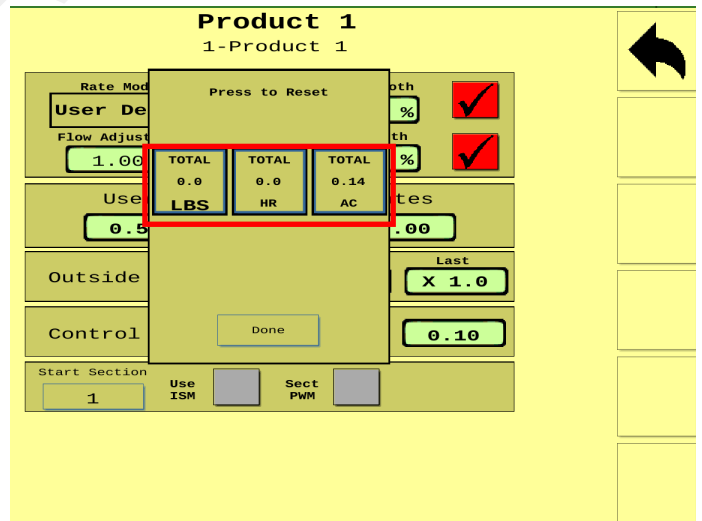
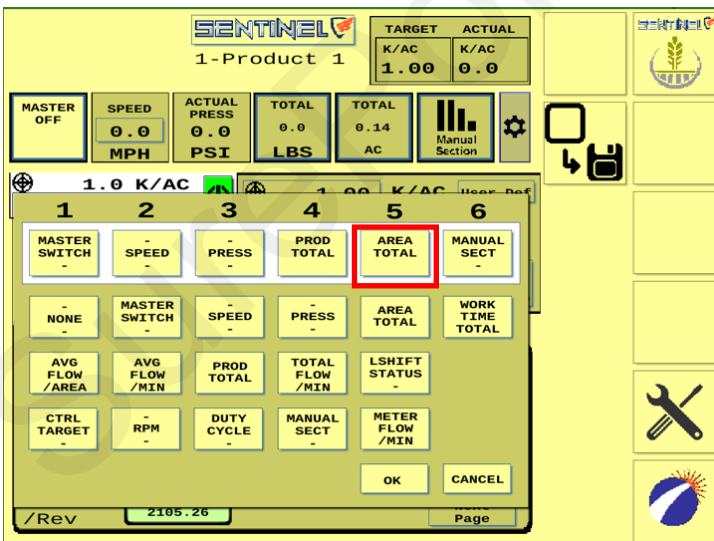

Push any of the **Reset** buttons to reset that total to 0.

To return without changing any of the totals, press **Done**.

Sentinel Dry Control Operation



Once the Sentinel has been set up in the display, little is required of the user to operate the Sentinel. The system can be started with an Implement Switch that will turn the system on when the implement is lowered. It can be turned on and off with a Master On/Off Switch (footswitch or on-screen). The system can also be turned on and off using Task Control to turn the system (or sections) on and off as the implement enters the field or overlaps previously applied areas using GPS location information.



Sentinel Wheat (Home) Button

Sentinel HOME Screen for Dry Control

On the HOME screen, the top row is a **Customizable Toolbar** with options to display several different system parameters.

Normal operation is with Duty Cycle and Section Control set to AUTO.

To run, there must be SPEED, Height Switch down, Master ON, Product switch ON (green), target rate set, and a working width.

Toggle between Rate 1, 2, and 3 on the go, or press the top Target Rate box and enter a different target. Press the gear/teardrop on the bottom right to go to the Rate Setup screen.

Center Section - If operating more than one product, all products will be shown on the left side of this section. The center section shows the Rate Control operation for each product. The user defined rates are available for selection on the go.

Bottom Section- will be the *Operate/Setup/Diagnostic Tabs*. Watching the information on the Diagnostic tab will help the user become familiar with normal operating parameters. Knowing what is normal can help the operator diagnose and fix the issue if a problem occurs.

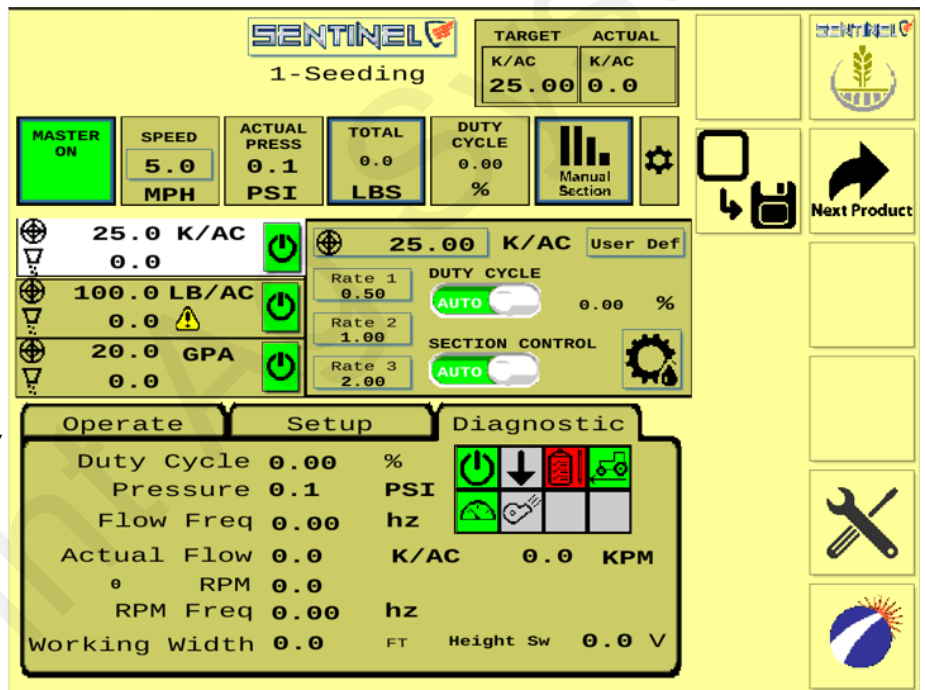

To operate manually, press **Speed**, enter a speed, select **DUTY CYCLE MAN**, enter a **DC%**, **Section Control: MAN**. **Master: ON**. **Height switch: DOWN** (if used) **Product switch : ON** (green)

To test the system, you can change the Duty Cycle % as the drive is running. Observe the rate (K/AC) Duty Cycle %.

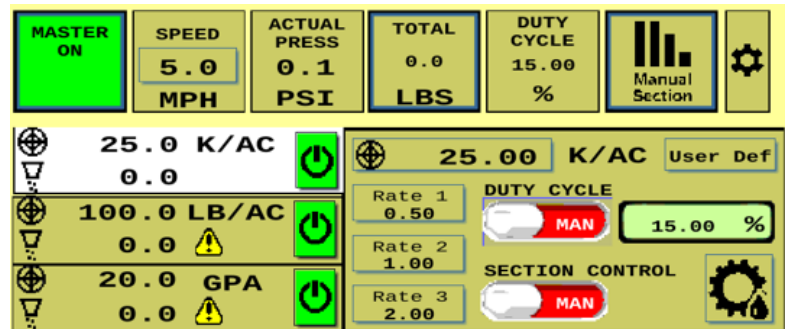

TESTS - Nozzle Test Used to test system with a simulated speed and target rate to see if all components are working. We recommend not having any product in the tank with a nozzle test

From the Product Setup page press the Nozzle Test icon (35). Be sure MASTER is OFF. Press NEXT.

Select which sections you want to run for this test. NEXT.

Enter SPEED and RATE. NEXT.

Turn MASTER ON to start the test. **Monitor Actual Rate, Flow per Minute, Duty Cycle (%), and Pump RPM (if monitoring RPM). These are important parameters of system operation. Know what they are during normal operation.**

To stop the test, turn MASTER OFF.

TESTS - Catch Test (v 1.5.0 and later)

Verify and adjust the flowmeter calibration.



From the Product Setup page press the Catch Test icon (36). Be sure MASTER is OFF. Press CATCH TEST (37).

Product 1

1-Product 1

Mode: Plant/Seed | Total Rows: 16 | Sections: 4 | Spacing: 30.00 Inch

Start Section: 1 | Implement Width: 40.0 FT | Tolerance: 25.0 %

| Sec# | Num Rows | Sec# | Num Rows | Sec# | Num Rows | Sec# | Num Rows |
|------|----------|------|----------|------|----------|------|----------|
| 1 | 4 | | | | | | |
| 2 | 4 | | | | | | |
| 3 | 4 | | | | | | |
| 4 | 4 | | | | | | |

Units: K-LB

36 (Catch Test icon)

Product 1

WARNING!! For an accurate sample make sure that the lines and pump are primed, the different rows sampled catch relatively the same amount and the system pressure is adequate. After changing the flow cal, run another test to verify the setting. Always verify with the area and amount of product used in the field after a calibration change.

Catch Test

If an expected and known volume is already known, enter the information below

Expected Volume: 0.00
Actual Volume: 0.00
Current Cal: 120.00
Proposed Cal: 120.00

Accept New Cal

Product 1

Catch Test

Ensure Master Switch is OFF to proceed with test.

MASTER OFF

Prev **Next**

Product 1

Select Sections to run for Test

Select which sections you want to run during the test or run with all sections ON.

Prev **Next**

Product 1

Catch Test

For the catch test, the system will run the previously selected sections until a specified volume is reached. Please enter the information below.

Enter the information based upon your rate requirements. These are only simulated values below.

Number Of Rows To Catch: 48
Simulated Speed: 5.0 MPH
Target Rate: 100.0 LB/AC
Volume to Dispense Per Row: 0 LBS

Prev **Next**

Product 1

Catch Test

Enable the Master Switch to begin the test. Disable the Master Switch to cancel and abort the test. Once the test is complete, press the Next button.

MASTER ON

Target/Actual Rate: 25.0 / 0.0 K/AC
Pressure: 0.0 PSI
Flow Per Minute: 0.0 KPM
Volume Target/Actual: 60 / 0 Count

The Volume Target is the volume per row multiplied by the number of rows being caught.

Cancel **Next**

SETUP for Dry Control - TESTS - Catch Test cont.

Verify and adjust the pulses/ rev calibration.

Product 1

WARNING!! For an accurate sample make sure that the lines and pump are primed, the different rows sampled catch relatively the same amount and the system pressure is adequate. After changing the flow cal, run another test to verify the setting. Always verify with the area and amount of product used in the field after a calibration change.

Catch Test

If an expected and known volume is already known, enter the information below

Expected Volume:

Actual Volume:

Current Cal: 120.00

Proposed Cal: 120.00

Accept New Cal

While the test is running, the actual rate and Flow per Minute will be shown. The Volume Target is the volume per row multiplied by the number of rows being caught. When the Volume Target for the test rows is reached, the test will stop. Add together the amount caught in all the rows tested. Enter this amount in **Actual Volume**.

After the test has ran enter your expected volume and the actual volume caught. Then hit Accept New Cal and it will update the calibration number in the Setup tab.

Repeat the catch test to verify consistency and accuracy.

Best practices dictate ongoing verification of acres worked and product applied to verify flow cal.

Sentinel Dry Control Troubleshooting

Sentinel doesn't show up on my display

E

Trouble-Shooting

1. Verify that the Sentinel ECU has power - 2 green lights should be illuminated on the ECU.
 - A. Using a voltage tester, check voltage on the ECU harness.
2. Do you have more than one display (VT)? Check to see if Sentinel booted up on the other display.
3. Check connections:
 - A. Tractor ISO plug
 - B. CAN and power connections leading to the ECU harness
4. Reboot everything.

System Won't Run

1. Look at Diagnostic Screen to see if any of the boxes aren't green. These should all be green for the system to operate correctly.
2. Is MASTER ON? Is the Product ON? Is there a SPEED? Is there a RATE? Switch Section Control from AUTO to MANUAL. Is there a Duty Cycle %? Is hydraulic flow ON and plumbed correctly?
3. On Hardware screen, uncheck TASK CONTROL. If you have TASK CONTROL checked on the Sentinel, Task Control must be activated and turned ON in the display software.
4. Verify settings for Master Switch and Implement Switch. If these boxes are checked, these items must be plugged into the Sentinel harnessing, not into harnessing for another control module. If using an IMPLEMENT SWITCH for Sentinel, is the orientation correct (check arrow on MASTER ON button)?
5. If there is a DC% showing, but the shaft is not turning, check the hydraulics. Verify there is voltage on the 2-pin PWM Connector.

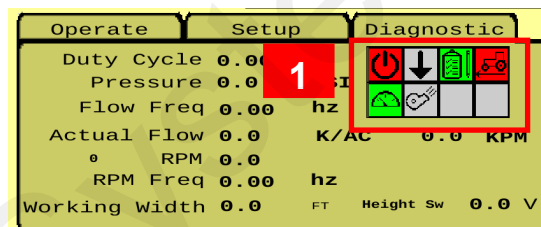

Manual Pump Operation

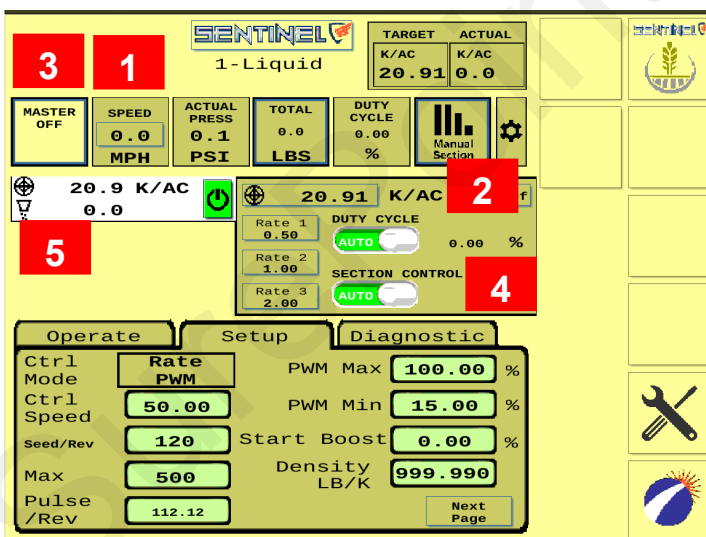

1. Enter a **SPEED** (tap the box and enter). Normal planting speed
2. Select a **RATE**. Select a rate at which you want to plant at.
3. **Master ON**. Should be green if you have height switch selected the implement needs to be correct position. Arrow should be down
4. **Section Control** - MAN. (slide toggle switch to red from green)
5. Observe Flow (K/AC) and Duty Cycle %. On hydraulic pump observe RPM.
6. If Duty Cycle / Rate / Flow oscillate and won't lock in, decrease the Control Speed on the Setup Tab (adjust hydraulic by 50). Adjust Control Speed as needed for best field performance.

Sentinel Doesn't display speed

1. Change the speed source. Toggle through the speed sources until speed displays.
2. If none of the speed sources are working, a communication problem with the tractor may exist. Consult your tractor dealer or add a GPS speed receiver found in the Accessories section of this manual.

Sentinel Care and Maintenance

F

Care &
Maintenance

Mounting— Always mount Sentinel ECU as shown, with electrical connections down to avoid water entering into ECU.



Cleaning

Under no circumstance should the Sentinel ECU be cleaned with a pressure washer. While the flow modules and ECU are sealed, the intense pressure generated by pressure washers may penetrate the seals and cause irreversible damage.



Repair

When welding on the implement, it is advised to unhook all cables going to the Sentinel ECU or any electrical components.

Pre-season Service

1. Visually check entire system (hoses, fittings, harnesses, etc.) for any signs of wear or trouble.
2. On the display, recheck all setup screens (see Section D) to verify correct setup.
3. Do a catch test to confirm calibration. For best results, do a catch test with the product to be used. Always verify calibration by comparing acres worked and product applied in the field.

Sentinel Accessories

Mounting Brackets & Accessories

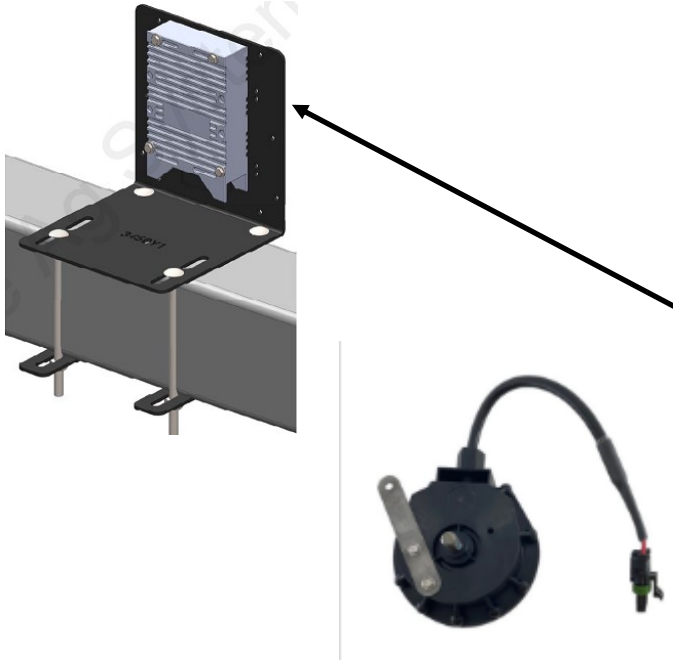
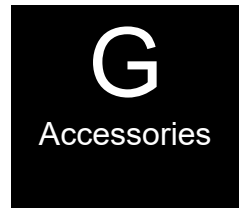

Sentinel Mounting Bracket and Accessories

| Part Number | Description |
|--------------------|---|
| 515-100950 | Sentinel ECU Mounting Bracket Kit |
| 204-04-464360178S1 | Dickey John 360 Encoder w/ 3-pin WP |
| 204-04-3500Y1 | Nickel Plated Full Thread Body Sprocket Drive Sensor (WP Shroud) |
| 229-03-467092221 | Dickey John 260 pulse/rev encoder coupler- adapts from encoder to 1/4" male bolt thread |
| | |
| | |
| | |
| | |
| | |
| | |

ISO Extension Harnesses

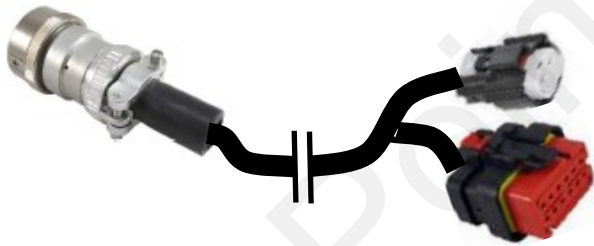

| Part Number | Description |
|---------------|------------------------------------|
| 214-00-3553Y1 | 10 FT. Front ISO Extension Harness |
| 214-00-3554Y1 | 20 FT. Front ISO Extension Harness |
| 214-00-3555Y1 | 30 FT. Front ISO Extension Harness |
| 214-00-3556Y1 | 40 FT. Front ISO Extension Harness |
| 214-00-3557Y1 | 50 FT. Front ISO Extension Harness |

Implement Height Switches



| Part Number | Description |
|---------------------|--------------------------------------|
| 501-100530 | Magnetic Finger Type Height Switch |
| 501-1005 | Magnetic Mercury Switch |
| 501-100520 / 100525 | Push Button Switch for Parallel Arms |

GPS Speed Receiver



| Part Number | Description |
|--------------|-----------------------------------|
| 203-01-01410 | Astro II with 3-pin MP 150 Shroud |

SENTINEL



SurePoint Ag Systems
9904 Hwy 25
Atwood, KS 67730

<https://support.SurePointAg.com>

©2016-2022 SurePoint Ag Systems