



396-4445Y1

Great Plains KultiStrip PumpRight and/or LiquiShift or NH3 Torpedo Mount Bracket Installation Instructions



Great Plains: KultiStrip 12R30F, 12R20F and 8R30F

Kit Number: 516-04-600100

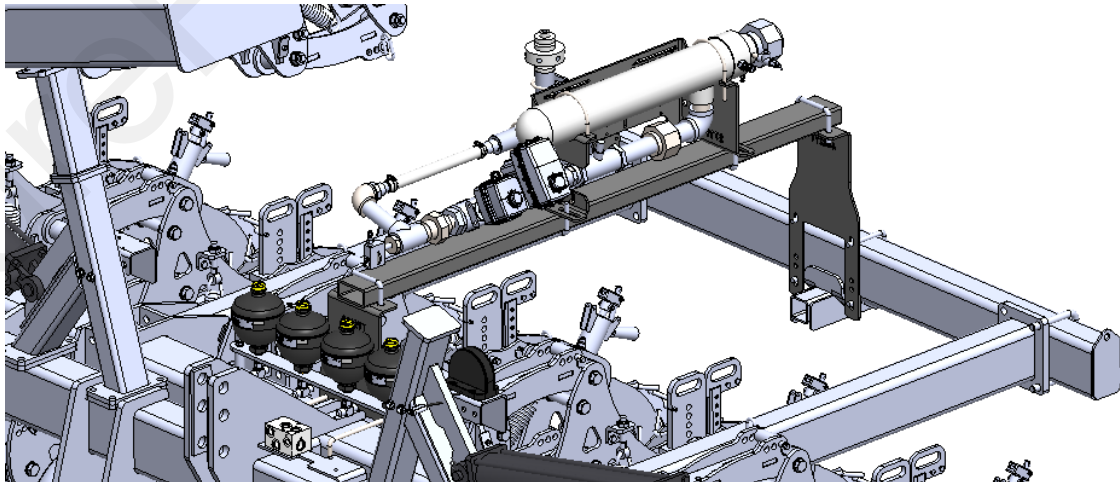
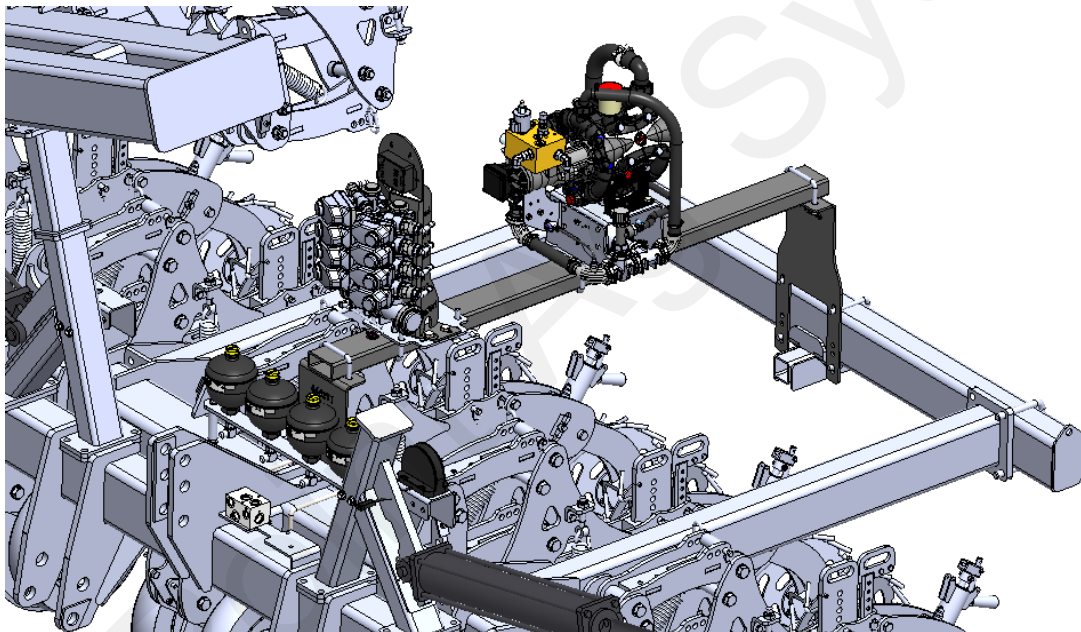



Parts List and Exploded View

Kit Number: 516-04-600100

ITEM NO.	PART NUMBER	DESCRIPTION	QTY.
1	448-4442Y1	GP KultiStrip - Vertical Support - Fits 7", 6", 5" and 4" Tall Tool Bar	2
2	448-4443Y1	GP KultiStrip - 2"x4"x66" Horizontal Mount Bar	1
3	448-4444Y1	GP KultiStrip - LiquiShift Mount Plate - Fits 4" Wide Bar	1
4	380-1001	1/2" U-bolt Kit - fits 7" x 7" tube - (7" opening) includes flange nuts	2
5	380-1017	1/2" U-bolt Kit - fits 6" x 4" tube - (6" opening) includes flange nuts	2
6	380-1037	1/2" U-bolt Kit - Fits 4" x 2" tube (4" opening) includes flange nuts	6
7	300-080100-5	1/2" x 1" Hex Head Bolt - G5	4
8	323-08	1/2" Flange Nut	4

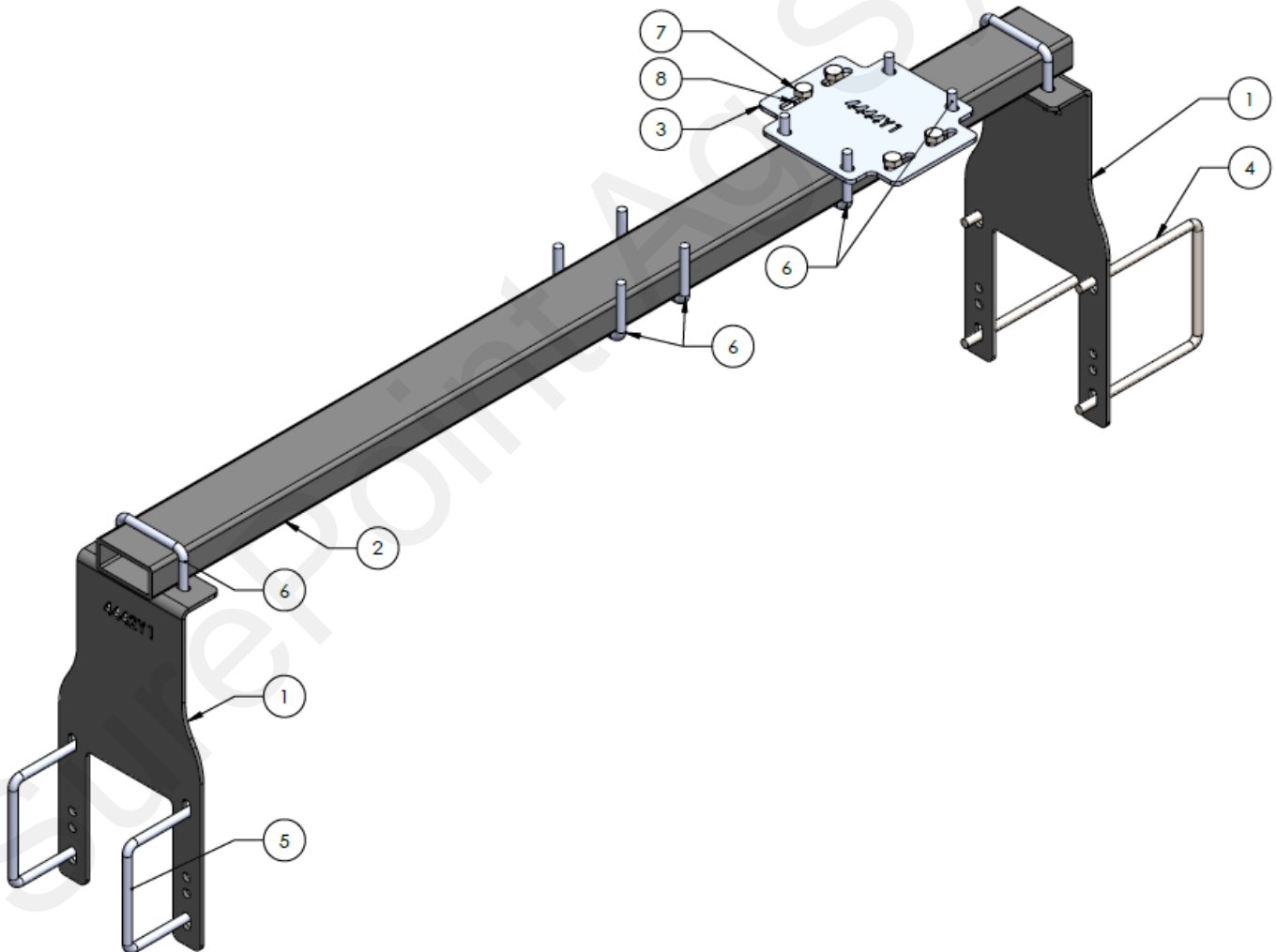

Step by Step Instructions PumpRight and/or LiquiShift Installation

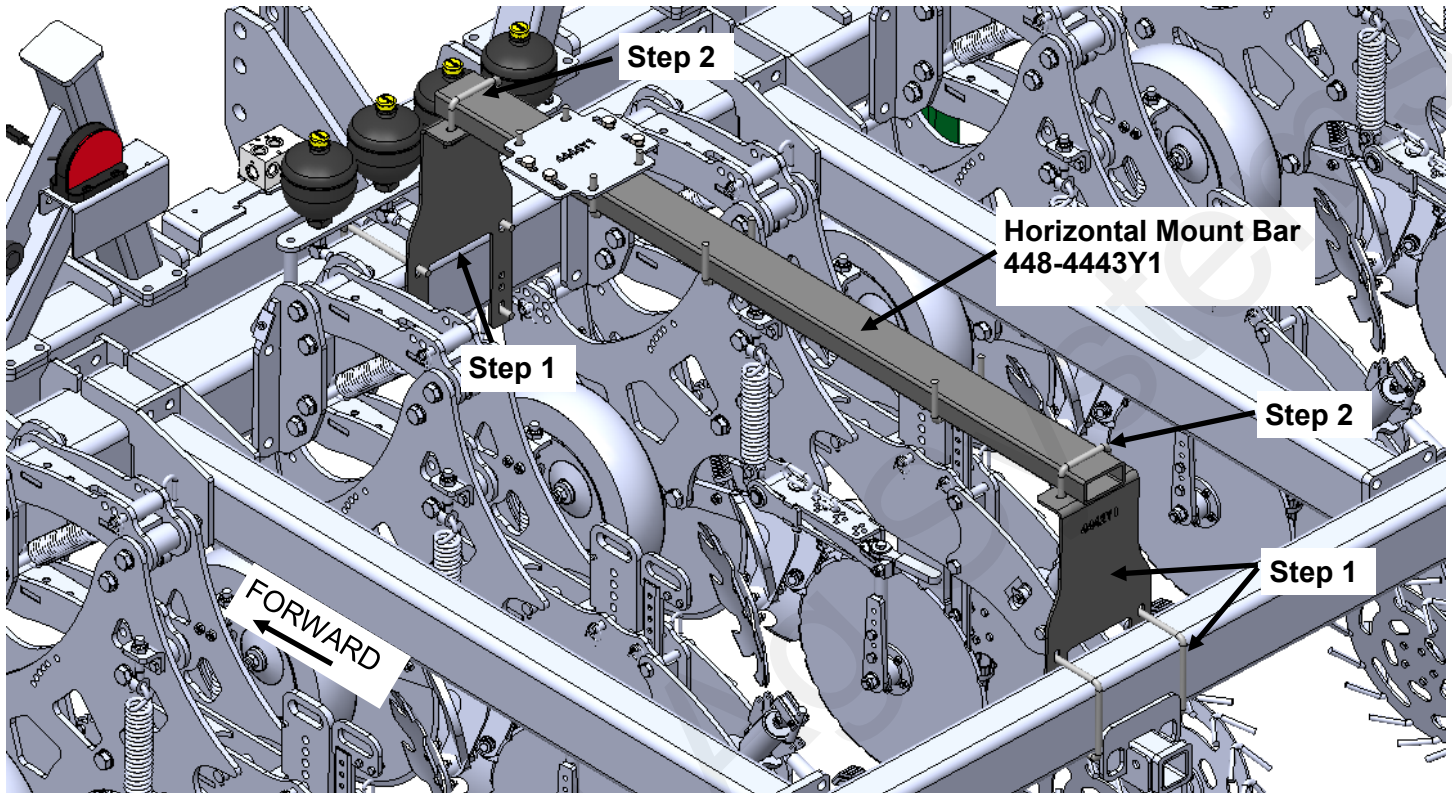

1. Mount Qty 2, 448-4442Y1 Vertical Support Brackets as shown centered on implement using the supplied 1/2" U-bolts. Qty 2, 380-1001 U-bolts for front main frame 7"x7" tool bar and Qty 2, 380-1017 U-bolts for rear hitch 4"x6" tool bar.
2. Mount the 448-4443Y1 Horizontal Mount Bar to the vertical supports as shown, using Qty 2, 380-1037 U-bolts. Tighten all U-bolts once brackets are in place.

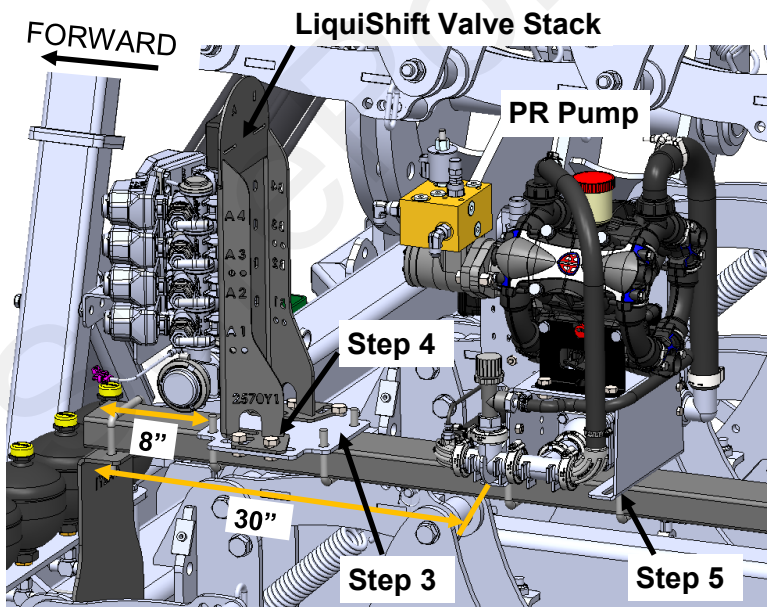

3. Mount 448-4444Y1 LiquiShift Mount Plate to Horizontal Mount Bar as shown, approx. 8 inches from front edge of Horizontal Bar, with Qty 2, 380-1037 U-bolts. Do not tighten to allow for adjustment in future steps.
4. Install LiquiShift Valve Stack to Mount Plate as shown using the supplied 1/2" hardware. Tighten the Valve Stack to the Mount Plate only, still leaving the U-bolts loose for adjustment.
5. Install PumpRight Pump onto Horizontal Mount Bar approx. 30 inches from front edge of Horizontal Bar using Qty 2, 380-1037 U-bolts. Do not tighten U-bolts.
6. Fold Implement to transportation mode CAREFULLY to make sure there is no interference with row units and newly installed equipment. Once verified that there is no interference and nothing needs slid up or down the Horizontal Bar, tighten all U-bolts.

Step by Step Instructions NH3 Torpedo Installation

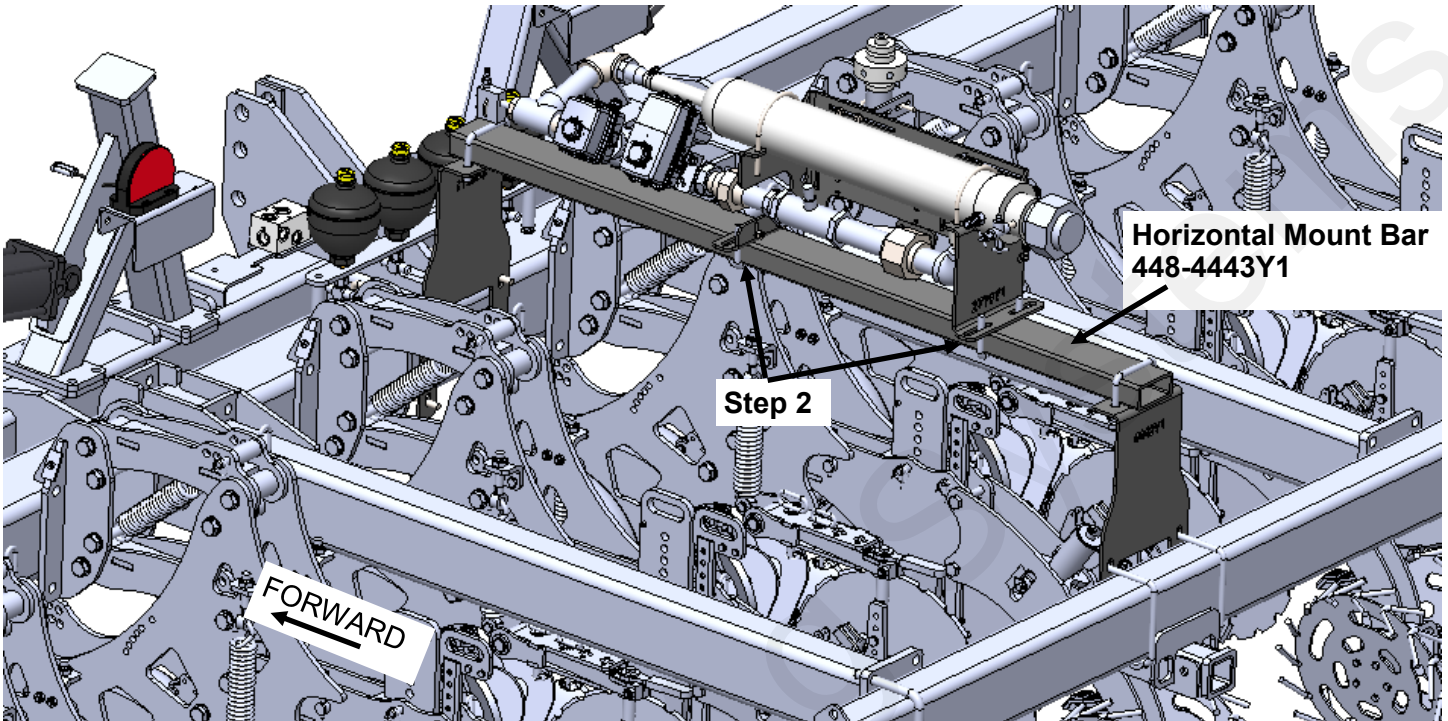

1. Repeat steps 1 and 2 from page 3. When mounting the Torpedo, parts that will NOT be used from kit 516-04-600100 are as follows...

ITEM NO.	PART NUMBER	DESCRIPTION	QTY.
3	448-4444Y1	GP KultiStrip - LiquiShift Mount Plate - Fits 4" Wide Bar	1
6	380-1037	1/2" U-bolt Kit - Fits 4" x 2" tube (4" opening) includes flange nuts	2
7	300-080100-5	1/2" x 1" Hex Head Bolt - G5	4
8	323-08	1/2" Flange Nut	4

2. Mount Torpedo onto Horizontal Mount Bar (448-443Y1) as shown above using Qty 2, 380-1037 U-bolts.
3. Leave U-bolts loose for adjustment up and down the horizontal bar.
4. Tighten U-bolts once you have final location of Torpedo set on horizontal bar and have figured out where the other NH3 componets will be mounted.