

396-3261Y1



High Pressure Fixed Rate SureBatch Manual

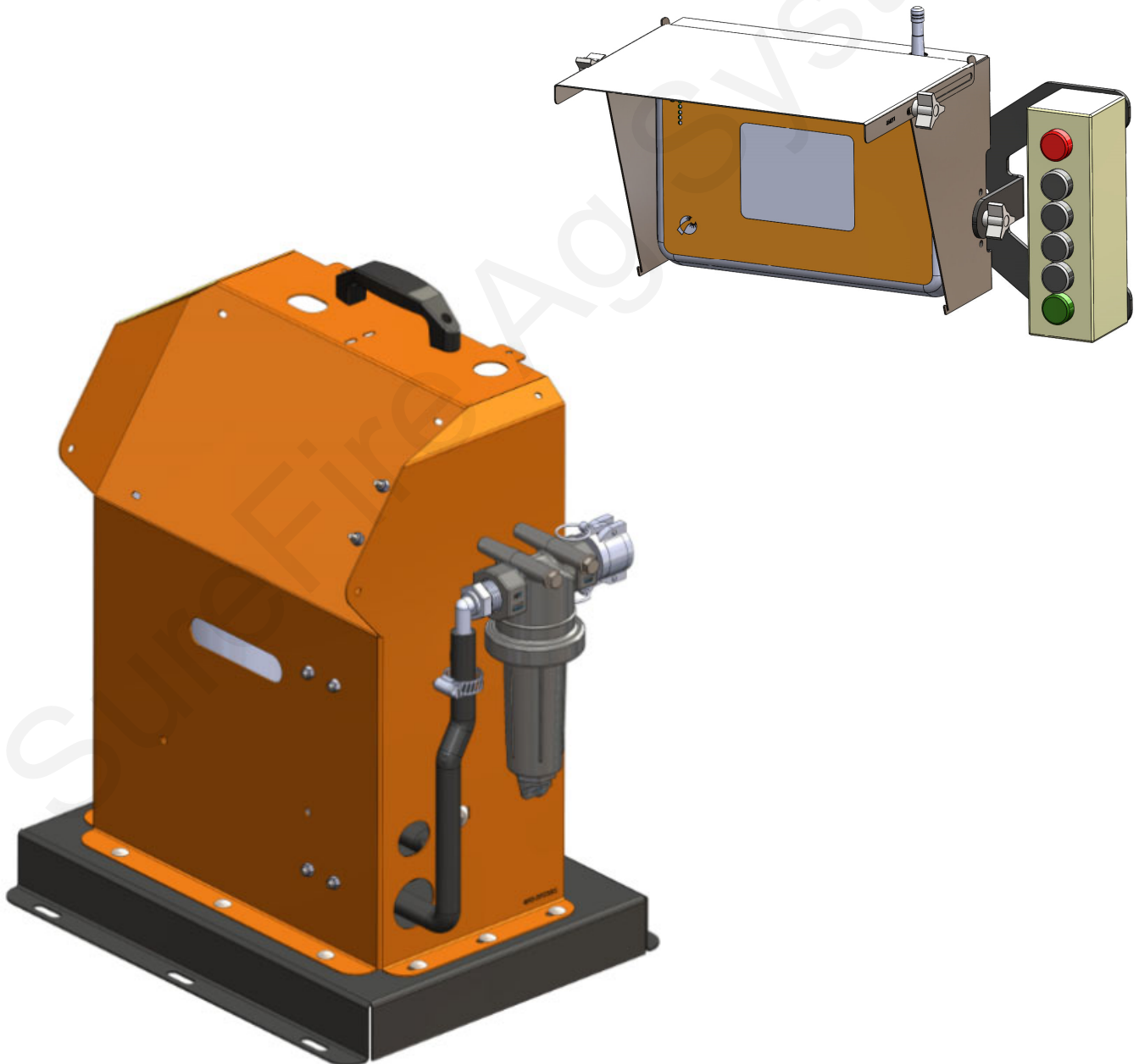

Table of Contents



Introduction

- **General Description and Setup**

Components—Liquid

- **Parts List**

Components—Electrical

- **Wiring Harness Diagrams**

Setup & Operation

- **Run Screen**
- **Settings**
- **Recipes**
- **Remote Control**

Troubleshooting

- **Common Problems**
- **PLC No Response - added 03/17/2022**

A

Introduction

B

Components
Liquid

D

Components
Electrical

F

Setup &
Operation

G

Trouble-
shooting

General Description



The SureBatch system can be used to precisely meter the correct amount of chemical into your system. The batch can be initiated using the touch screen interface or with the large push buttons. All settings are made using the touch screen interface. Help information is available on the touchscreen by pressing the on screen ? symbol.



Basic Setup

1. Connect your product to the 3/4" female cam lock coupler on the inlet strainer.
2. Connect the port labeled OUT to the 20' high pressure hose. This hose will connect to the NH3 tank filling station or the NH3 tank coupler assembly.
3. Mount the controller and push buttons in your desired location. Connect the controller to the base pumping unit with the 10 pin extension harness.
4. Plug the 120VAC cord into an outlet.

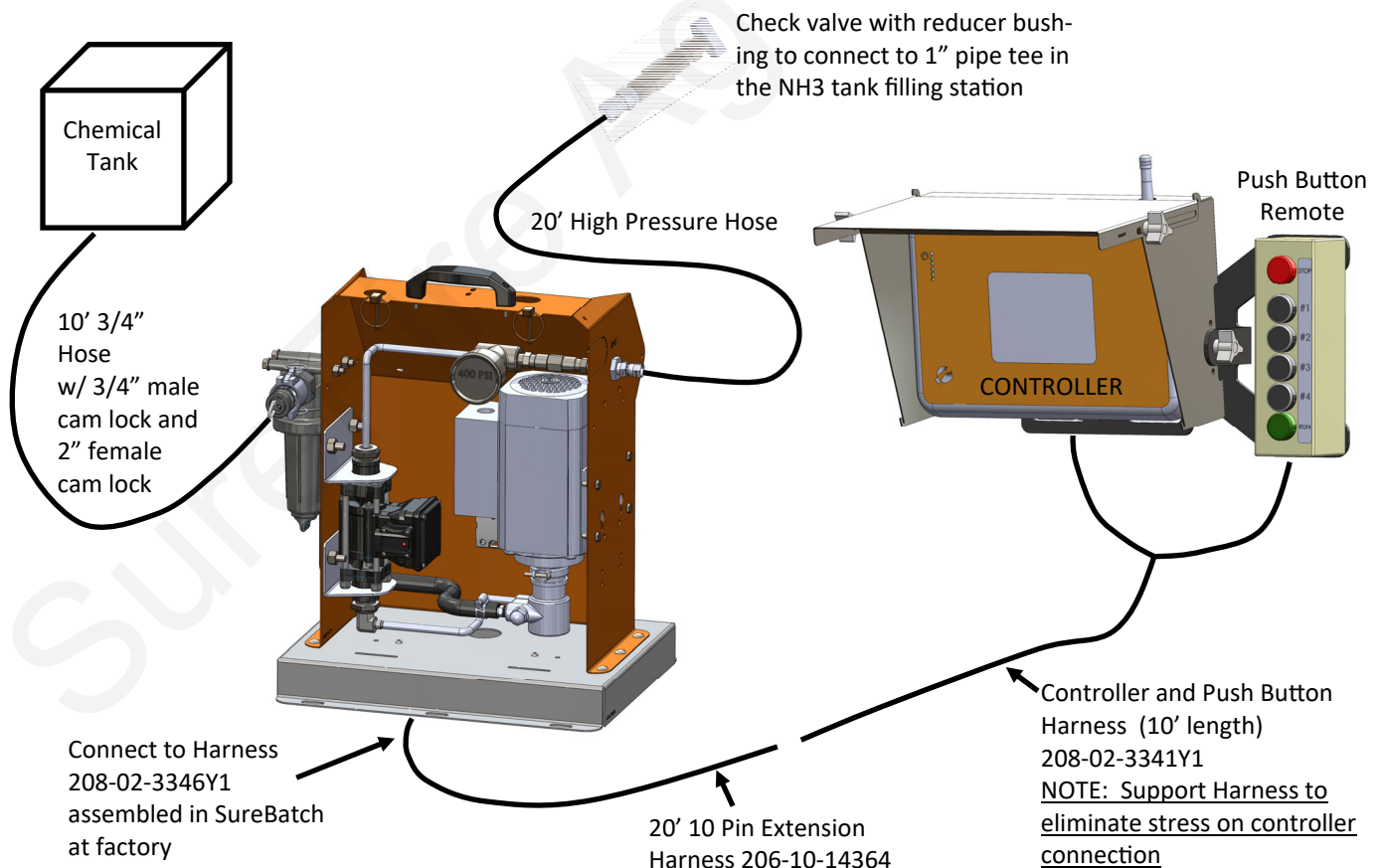

High Pressure SureBatch Accessories



SureFire offers these accessories that you may want depending on exactly how you will install and utilize your high pressure SureBatch.

NH3 Tank Couplers

If you will be hooking up directly to NH3 tanks order the tank coupler kit in the proper size for the tanks you will fill.

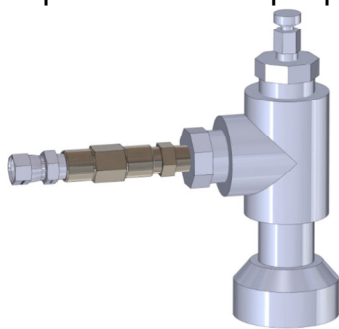

NH3 Tank Coupler w/
1 3/4" ACME
545-01-100100

NH3 Tank Coupler w/
2 1/4" ACME
545-01-100150

Wireless Remote Control

The SureBatch controller has wireless capability built in. Add the Wireless Remote Control to start, stop and load recipes from any location within 30 feet of the SureBatch controller. **Wireless remote is not weather proof and must be stored in a dry location**

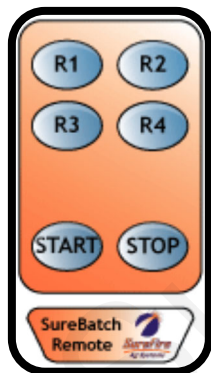

SureBatch Wireless
Remote Control
Part #: 469-01-1128Y1

Parts List



B
Components
Liquid

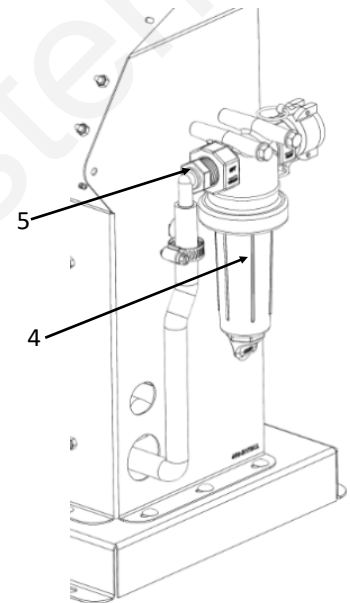
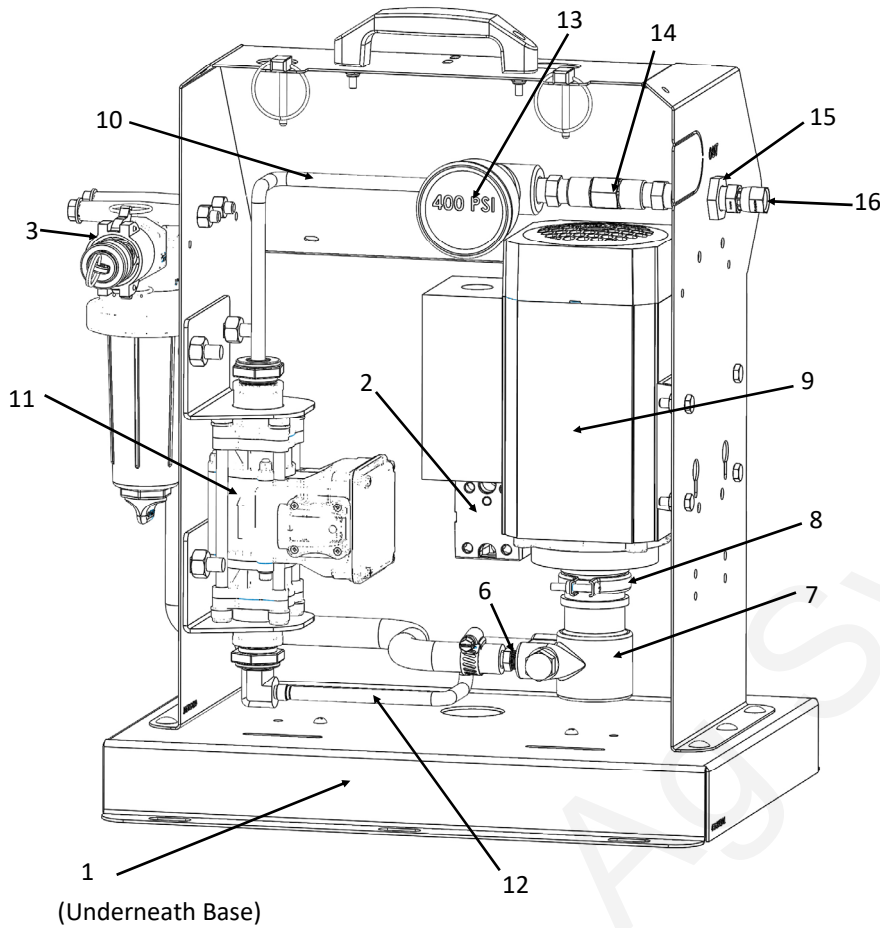

1	208-07-3241Y1	5 Amp, 12 Volt Power Supply
2	217-3242Y1	10 Amp Pump Start Relay
3	106-075B	3/4" Female Coupler x 3/4" MPT
4	109-075LST-80V	3/4" Tee Strainer -Viton - 80 Mesh
5	101-075050-90	3/4" MPT x 1/2" HB - 90 Degree
6	101-038050	3/8" MPT x 1/2" HB (Pump Inlet)
7	290-12-103A070R31RA-250	Procon Rotary Vane Pump - 70GPH/1.16GPM
8	352-01-1113	Pump Attachment Band Clamp
9	210-3413Y1	Weather Tight Motor, 115VAC 1PH, 1640 RPM, 3.69 Amps
10	283-01-038-06FPT-12	3/8" SS Braided Hose - 3/8" NPTF Male x 3/8" NPTF Male - 12" L
11	204-01-4621AA01313	Electro Magnetic Flow Meter 0.13 - 2.6 GPM (OK to sub 0.3 - 5 GPM model)
12	283-01-038-06FPT-09	3/8" SS Braided Hose - 3/8" NPTF Male x 3/8" NPTF Male - 8" L
13	137-LFG400-BM	2 1/2" Silicone Filled Stainless Gauge - 400 PSI - 1/4" MPT Back Mount
14	136-01-C600SS	3/8" FPT SS Check Valve w/ Nitrile (NBR) Seal - 5 PSI Cracking - 5000 PSI Max
15	153-W17709	3/8" NPT Female Bulkhead Coupling
16	161-09-6MP-6FJX-SS	3/8" NPT Male to Female JIC Swivel

Wire Size 18AWG Unless otherwise specified

Cap shipped on this side of controller connector; do not remove

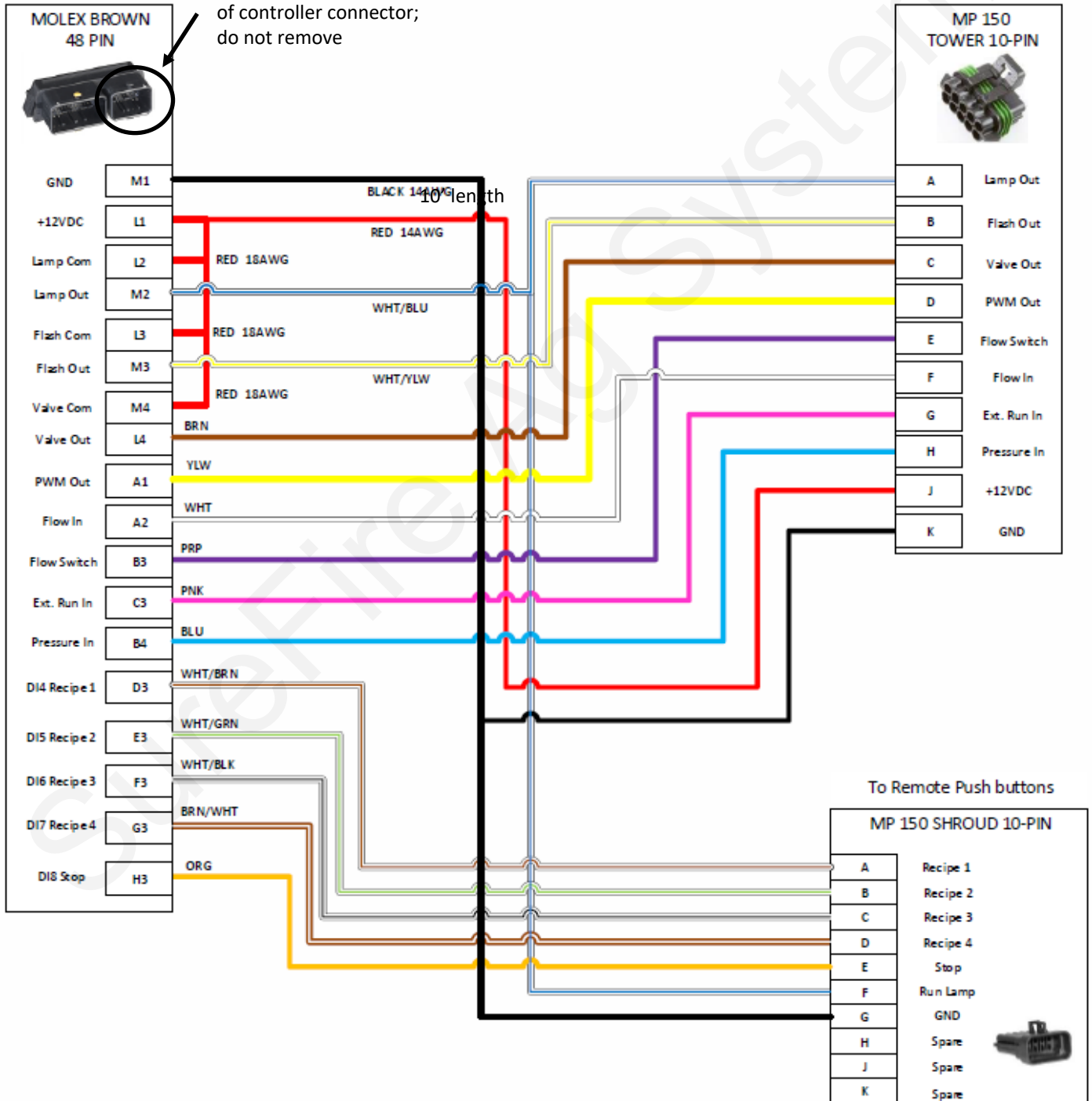

Fixed Rate 110VAC Surebatch
Final Harness
208-02-3346Y1

10 Amp Pump Start Relay
208-07-3241Y1

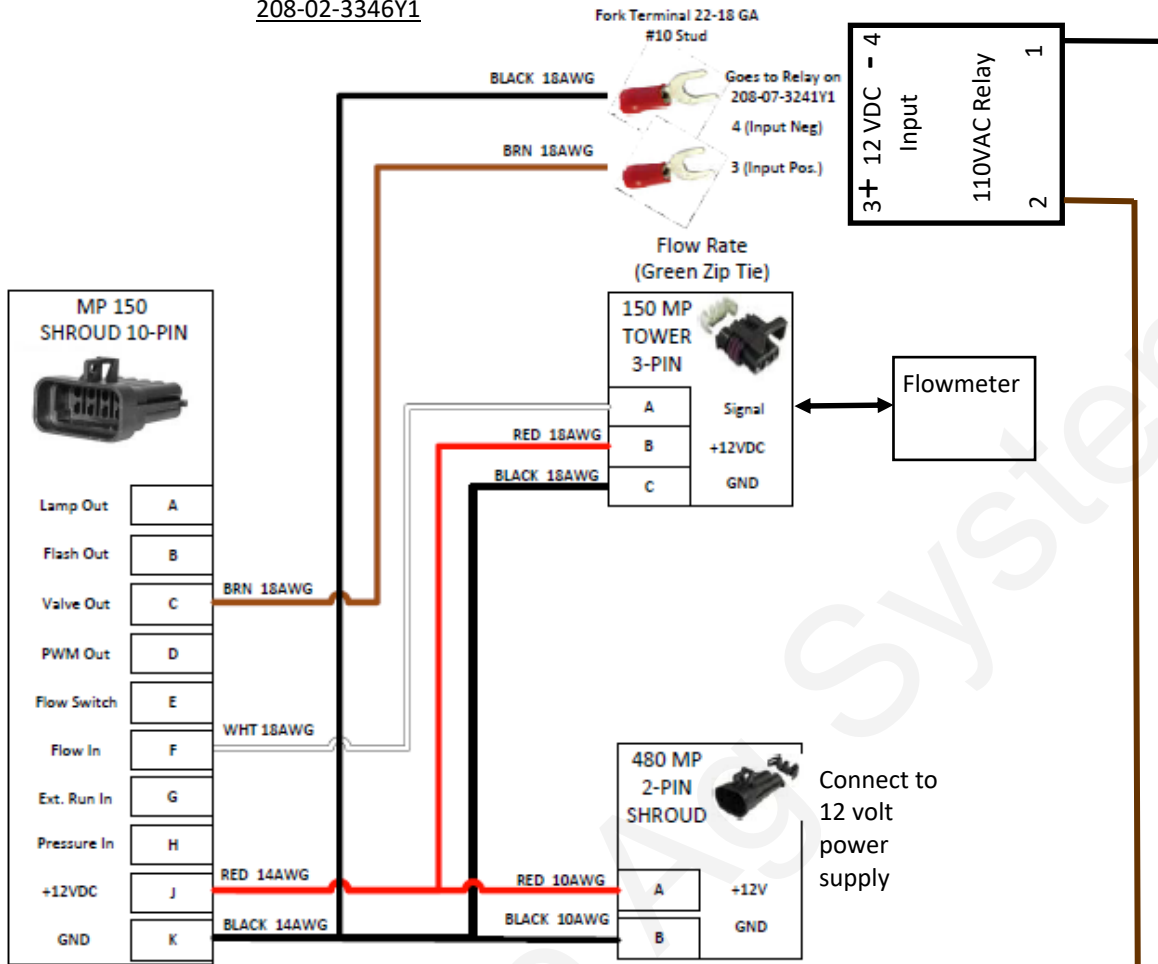

CAUTION: RISK OF SERIOUS INJURY!
WITH THIS HARNESS PLUGGED IN, THE BROWN FLYING LEAD TO THE RELAY WILL HAVE 120VAC ON IT! ENSURE THE END OF THE LEAD IS PROPERLY INSULATED BEFORE PLUGGING THE HARNESS INTO 120VAC!

SureBatch 110V Power Harness
with 110V Pump Supply
208-07-3241Y1

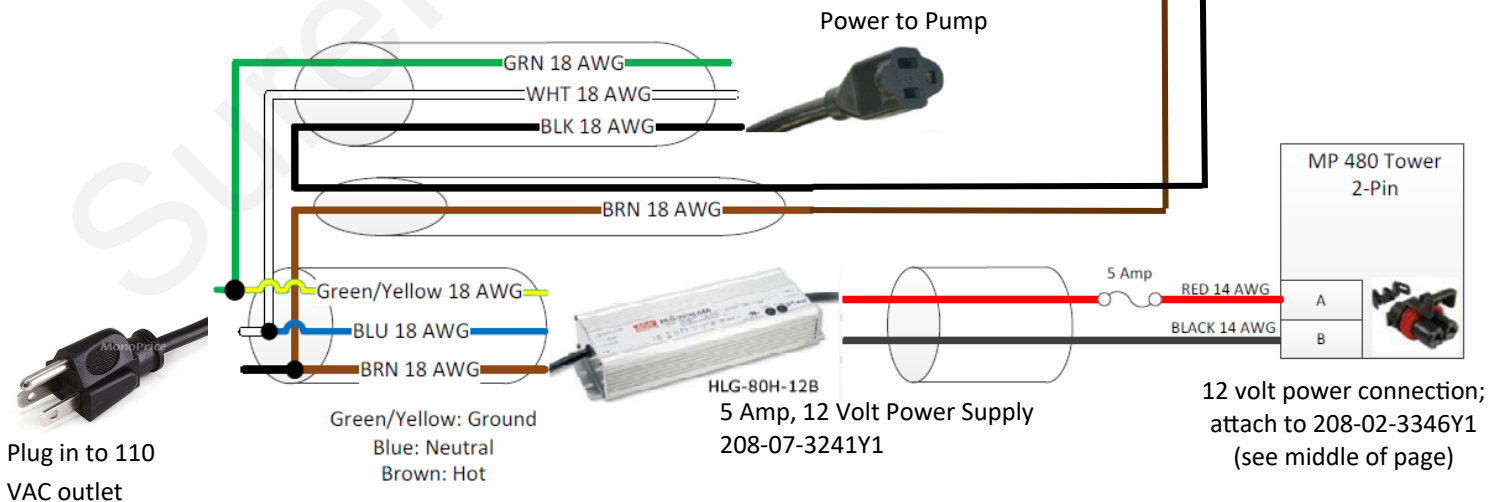

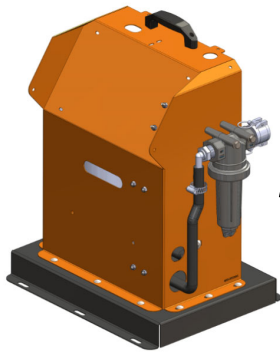

High Pressure Fixed Rate SureBatch Controller Quick Start Card 396-3263Y1

F
Setup &
Operation

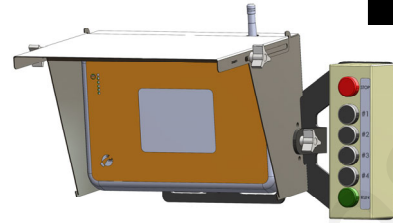

RUN Screen—AUTO Mode

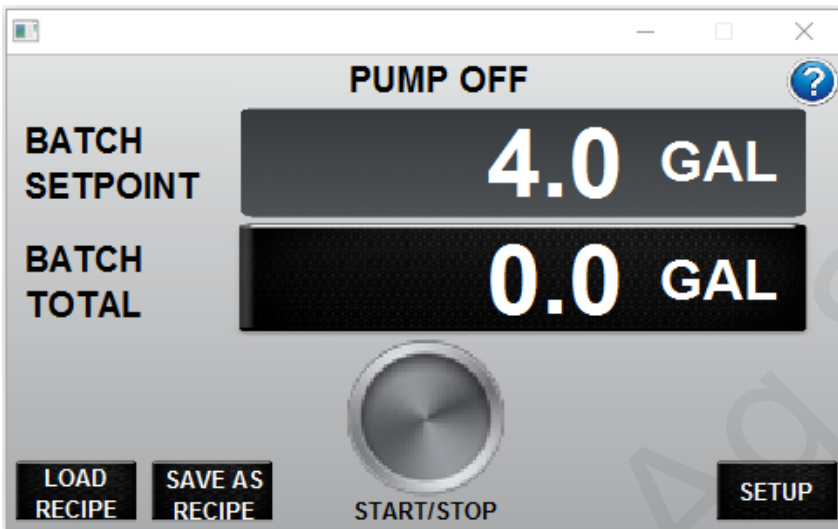

The BATCH SETPOINT and BATCH TOTAL are shown on the RUN Screen.

The Batch Setpoint shows what Batch Volume it will pump when the start button is pushed.

The Batch Total is the amount of product that has been pumped.

The controller shown to the left is currently not running (Pump Off & Current Batch Total 0.0 GPM). The Batch Setpoint is set for 4.0 GAL; when the start button is pressed, 4.0 gallons will be dispensed.

RUN Screen—MANUAL Mode

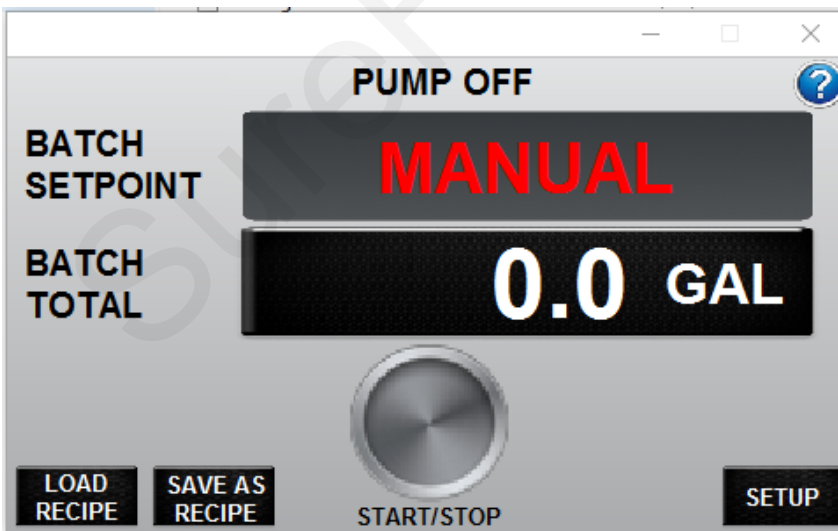

When the MANUAL/AUTO switch is in the Manual position (Switch is located on the Operational Settings Screen in the Setup Tab), the pump can be started and will run until stop is pushed. **In Manual operation there is no automatic batching.**



The question mark in the top right corner has help information for any screen.

OPERATIONAL SETTINGS Screen

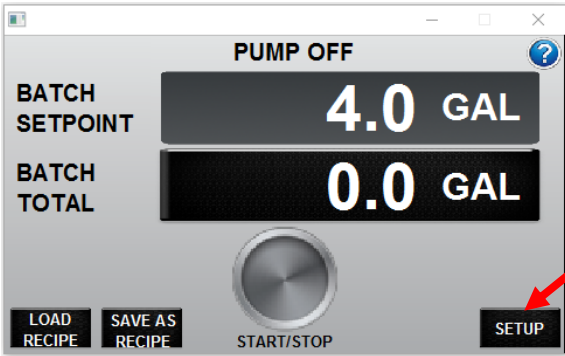

To navigate to the operational settings screen, press the SETUP button on the RUN screen.

Flow Rate shows rate of product being pumped in GPM.

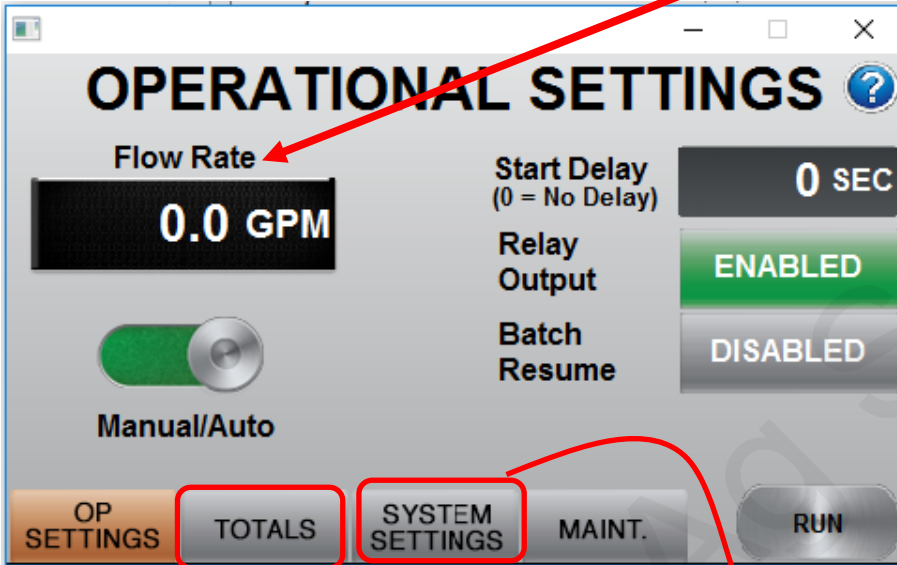

The **START DELAY** is used to delay the start of a batch by the number of seconds you enter.

The RELAY OUTPUT MUST BE ENABLED on the fixed rate SureBatch.

BATCH RESUME allows for the ability to stop a batch in the middle of pumping and then resume it at a later time. If DISABLED, any time the unit stops, a new complete batch will be pumped when started again. If BATCH RESUME is ENABLED, and a batch is started and then stopped, the batch will then finish from where it left off when it is restarted.

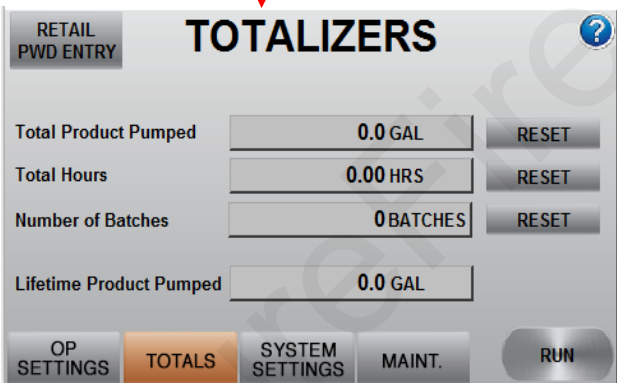

TOTAL PRODUCT PUMPED is a resettable totalizer to get a combined total of several batches.

TOTAL HOURS is resettable total of hours the SureBatch has been run.

NUMBER OF BATCHES is resettable total of batches completed.

LIFETIME PRODUCT PUMPED is a non resettable totalizer that counts the total pumped by the SureBatch.

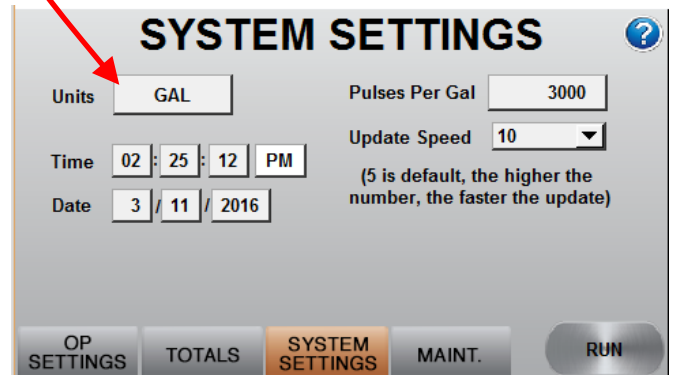

For fixed rate SureBatch set the parameters to:

Flowmeter (GPM):	.13 to 2.6	.3 to 5
Pulses Per Gal:	3000	3000
Update Speed:	10	10
Units:	Gallons	Gallons

Maintenance

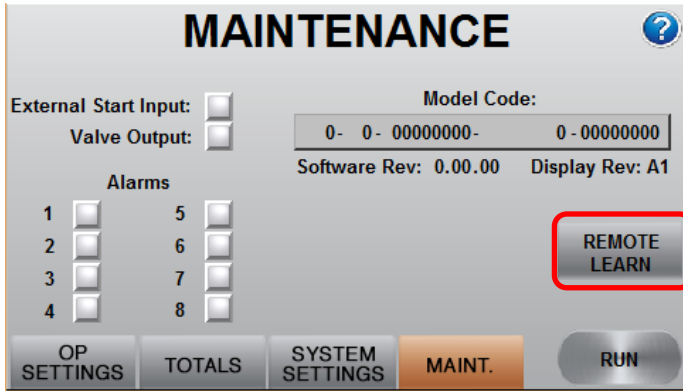

The maintenance screen has indicators and model and software info to use for troubleshooting.

REMOTE LEARN is used to program a new wireless remote control if not working.

1. Press the REMOTE LEARN button, and the blue Mode light will start flashing.
2. Hold down the STOP button on the remote until the blue mode light goes solid. This will take about 30 seconds.
3. Release the button on the remote, and now your new remote is paired to the controller.

Recipe Management—Saving a Recipe

Recipes are a convenient way to store four different batch sizes in the SureBatch.

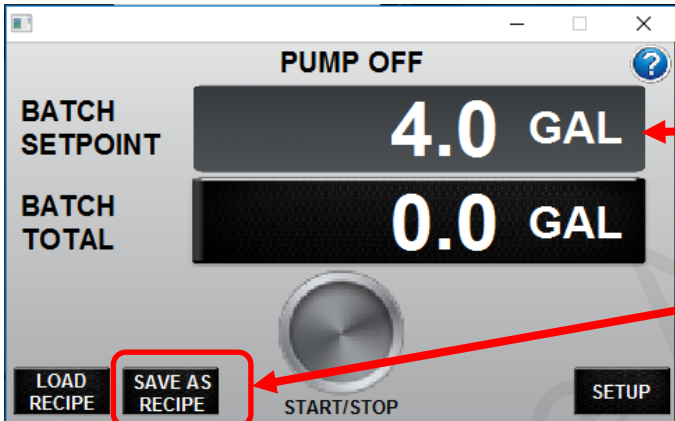

To SAVE RECIPE first set the Batch Setpoint setting. Here the batch size is 4.0 GAL. Then push SAVE AS RECIPE.

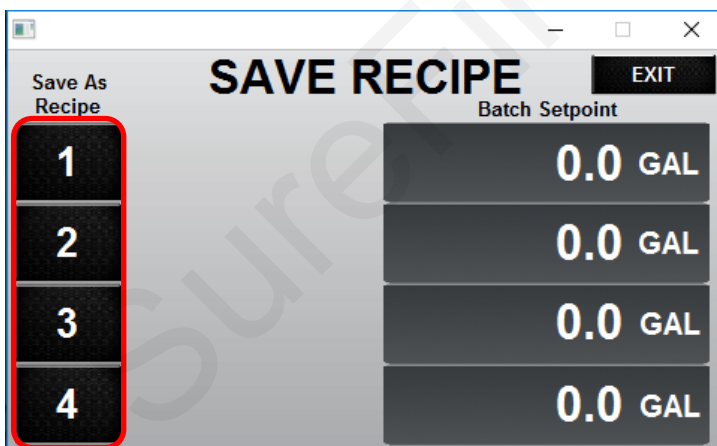

When the SAVE RECIPE screen opens, select a recipe number for this batch size by pushing on the number 1-4.



A yellow screen will pop up to confirm you want to save the recipe; select YES.

Recipe Management - Loading a Recipe

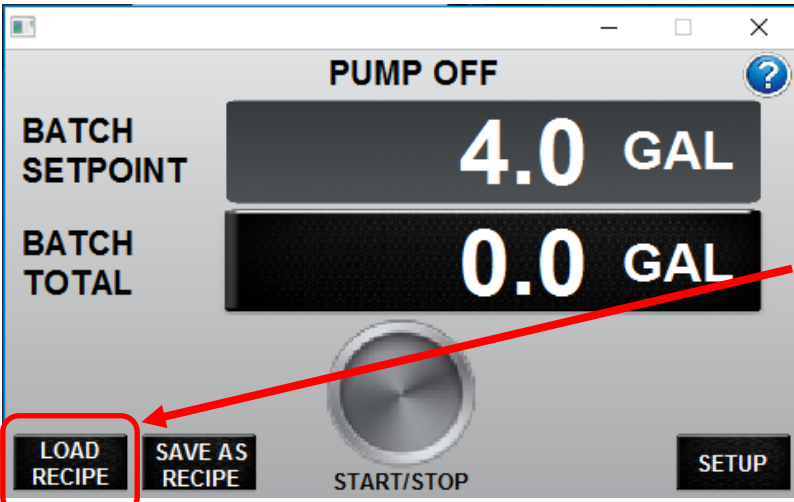

To see the saved recipes press LOAD RECIPE.

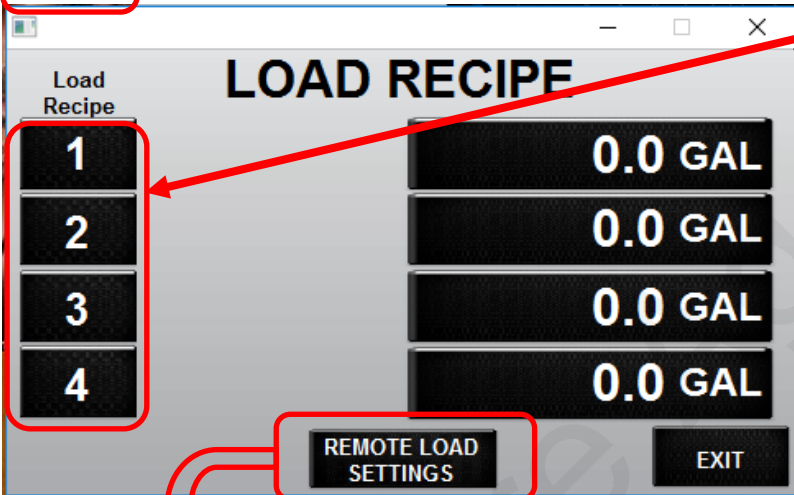

To load a recipe press the recipe number 1-4.

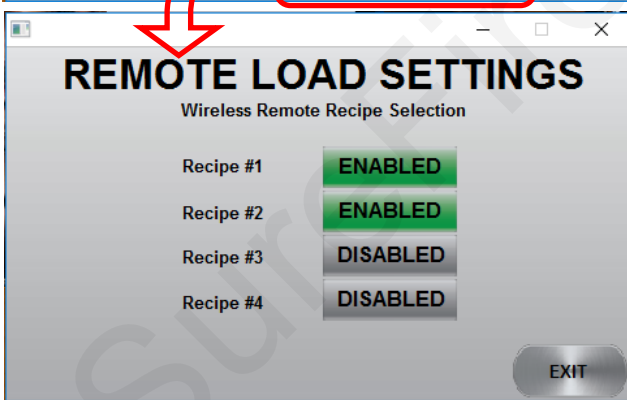

This screen sets if the #1-#4 buttons on the Push Button Remote Box or the R1-R4 Buttons on the Wireless Remote will select a recipe. As set here, #1/R1 button loads recipe 1 and starts the batch. #2/R2 does the same for recipe 2. #3/R3 and #4/R4 buttons will do nothing because they are DISABLED.

The START and STOP buttons on the remote control will always start and stop the current batch even if R1, R2, R3 and R4 are DISABLED.

Note: To run or stop a recipe batch with the Pushbutton Box, you need to press and hold the recipe button for at least 1 second to initiate button command. This is for prevention of running incorrect batch accidentally.

Note: To run or stop a recipe batch with the Pushbutton Box, you need to press and hold the recipe button for at least 1 second to initiate button command. This is for prevention of running incorrect batch accidentally.

Pushbutton Remote Box

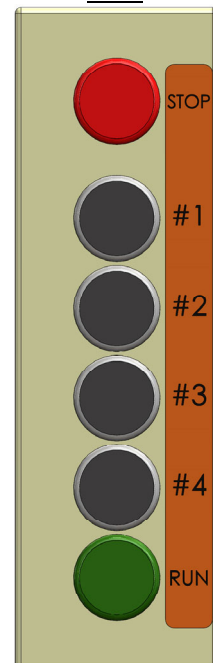

Wireless Remote

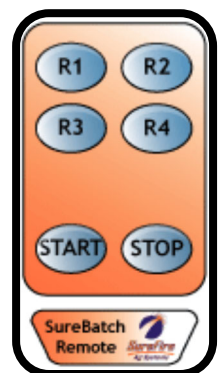

Troubleshooting



Touch screen not on:

- Check wiring, and check the inline fuse in the 12 volt wires coming from the 12 volt power supply. Do not use a fuse larger than 5 Amps.
- Make sure the power switch is on.

No Flow Rate:

- The pump will self prime, but sometimes it takes a little time for the system to get primed. Until product is flowing through the flow meter, it will read no flow. To help with priming do the following
 - a. Set the MANUAL/AUTO switch to MANUAL
 - b. Press the START/STOP to turn on the pump. Now the pump will run continuously.
 - c. Once you know product is moving through the system press the START/STOP button to shut the system off, and press the MANUAL/AUTO switch to switch back to AUTO.

Pump will not Run:

- On the Operational Settings screen, verify the "Relay Output" is enabled. If this is disabled the controller will not energize the pump start relay.
- Unplug the pump from the relay output and plug it directly into a 110 VAC outlet. If pump works fine this way then troubleshoot the relay.
- On the controller, go to manual mode and push start. On the input side of the Pump Start Relay, measure between "+" #4 Terminal and "-" #3 Terminal. You should have 12 volts here when the controller is turning the pump on. If you do not have 12 volts. it is a controller problem; call SureFire for further assistance. If you do have 12 volts, then suspect the relay has failed; call SureFire for further assistance.

System never stops:

- Make sure that the Flow Rate is displaying a flow. If it is not, then the Current BATCH TOTAL will not increment and reach the BATCH SETPOINT.

Remote Control will not start and stop pump:

- Relearn remote control; see Section F.
- Check remote control battery

Remote Control will start and stop pump, but 1-4 recipe buttons do nothing:

- The 1-4 buttons must be individually enabled. Go to Load Recipe screen, then Remote Load Settings to enable buttons 1-4.

PLC No Response

- The controller has lost communication with the display.
- May appear momentarily during system startup.
- May appear when pump tries to start at high power. The sudden power surge can brown out the controller, shutting off pump and triggering PLC No Response.
- To get around this, set pump startup at a lower speed(10% to 50% or so). Let pump speed up from here as necessary.
- Get software update 2.0.2. This ramps up the startup speed automatically.

A large, bold, white capital letter 'G' centered on a black square background.

Trouble-
shooting

Catch Test and Flow Meter Calibration



All SureBatch's are calibrated before they leave SureFire Ag, but it is good practice to do a one gallon catch test before the SureBatch is used to pump intended product.

A 128oz calibration pitcher is included with the product update package.

Procedures for completing a 1 Gallon Catch test are as follows...

1. Make sure the controller is set to Auto Mode on the Operational Settings Screen. Also, make sure the "Units" and "Pulses Per Gallon" read as shown in the System Settings Tab.

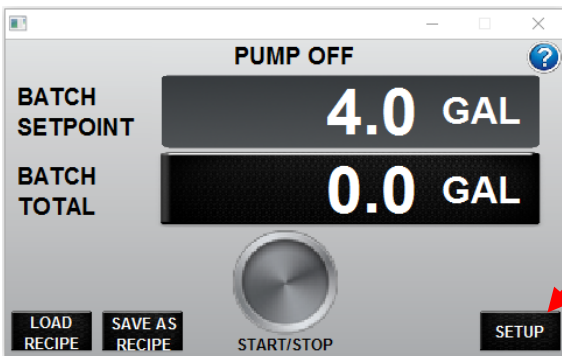

To get to the Operational Settings screen, press the SETUP button on the RUN screen.

Set to Auto Mode

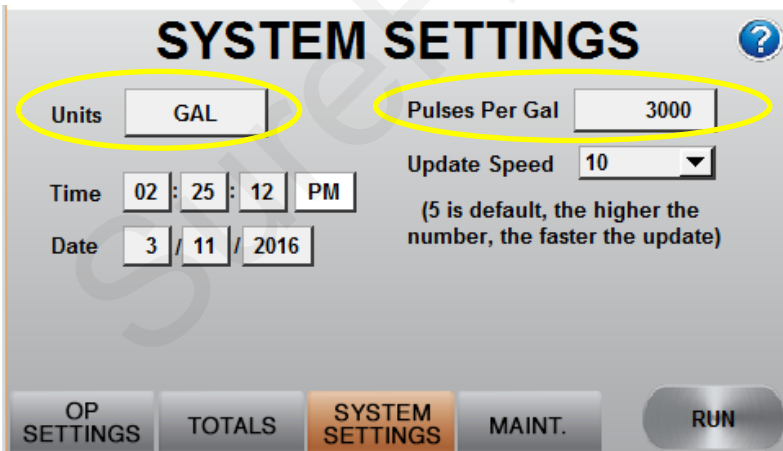
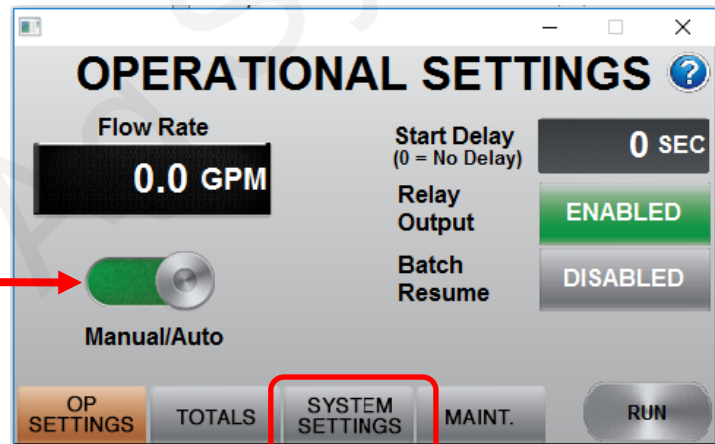

Press the System Settings button, Make sure "Units" is set to GAL and "Pulses per Gallon" is set to 3000. As shown to the left.

Procedures for completing a 1 Gallon Catch test continued...

2. Set the Batch Set Point to 1 GAL on the Run Screen.

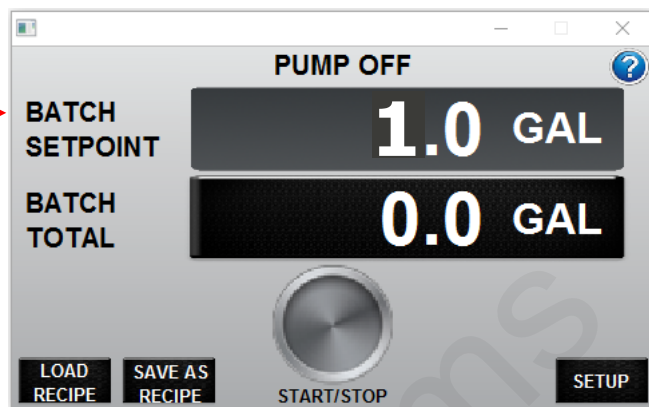

3. Hit the Start Button to start the catch test into the pitcher. Once the Test is done, the Batch Total should Read 1 GAL and the Pitcher should be at the 128oz level.

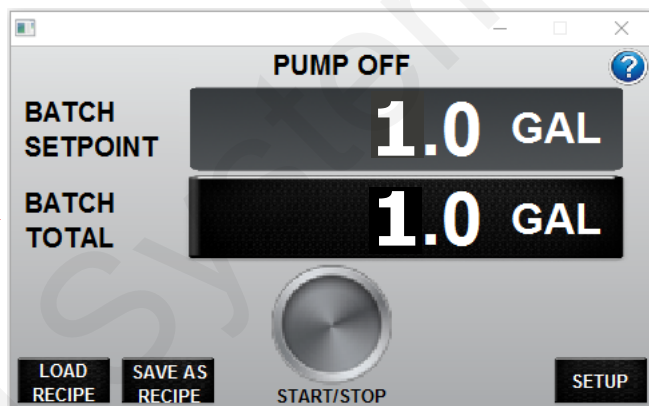

If the catch test is off, update the Pulses Per Gallon on the System Settings Screen according to the formula below...

Readjusting Flow Cal (Pulses per Gallon) after Catch Test

Formula: $(\text{Controller Gallons} \times \text{Controller Flow Cal}) / \text{Actual Gallons Caught} = \text{New Flow Meter Cal}$

Example: $(1 \text{ Gal Batch} \times 3000 \text{ Flow Cal}) / .93 \text{ Gal Caught} = 3225 \text{ New Flow Cal}$

If the Pitcher overflows during your catch test, adjust the Pulses Per Gallon lower and run the catch test over until you get to a level on the pitcher that is measurable (Under 128oz).

Then redo the catch test and Flow Cal readjustment formula above.

Declaration of Conformity

TRADE NAME:	SureBatch Controller
MODEL NUMBER:	SB200
COMPLIANCE TEST REPORT NUMBER:	B20906A1
COMPLIANCE TEST REPORT DATE:	9/12/2012
RESPONSIBLE PARTY(IN USA):	SureFire Ag Systems
ADDRESS:	9904 Hwy 25
TELEPHONE:	785.626.3670

This equipment has been tested and found to comply with the Class B limits of CFR Title 47, Part 15, Subpart B for the Receiver portion and complies with the Class A limits of CFR Title 47, Part 15, Subpart B for the digital portion.. These limits are designed to provide reasonable protection against harmful interference in a residential installation. This equipment generates, uses, and can radiate radio frequency energy and, if not installed and used in accordance with the instructions, may cause harmful interference to radio communications. However, there is no guarantee that interference will not occur in a particular installation.

If the unit does cause harmful interference to radio or television reception, please refer to your user's manual for instructions on correcting the problem.

I the undersigned, hereby declare that the equipment specified above conforms to the above requirements.

Place: Atwood, Kansas

Date: 9/28/2012

Signature: 

Full Name: Albert Popp

Position: Engineer

INSTRUCTION TO THE USER

This equipment has been tested and found to comply with the limits for a class B digital device, pursuant to part 15 of the FCC Rules. These limits are designed to provide reasonable protection against harmful interference in a residential installation. This equipment generates, uses and can radiate radio frequency energy and if not installed and used in accordance with the instructions, may cause harmful interference to radio communications. However, there is no guarantee that interference will not occur in a particular installation. If this equipment does cause harmful interference to radio or television reception, which can be determined by turning the equipment off and on, the user is encouraged to try to correct the interference by one or more of the following measures:

- * Reorient or relocate the receiving antenna.
- * Increase the separation between the equipment and receiver.
- * Connect the equipment into an outlet on a circuit different from that to which the receiver is connected.
- * Consult the dealer or an experienced radio/TV technician for help.

In order to maintain compliance with FCC regulations, shielded cables must be used with this equipment. Operation with non-approved equipment or unshielded cables is likely to result in interference to radio and TV reception. The user is cautioned that changes and modifications made to the equipment without the approval of manufacturer could void the user's authority to operate this equipment.