

396-3052Y1



SureFire
Ag Systems

Ag Leader[®]
Technology



NUTRISPHERE-N[®]

Nitrogen Fertilizer Manager



VERDESIAN

SureFire Catalyst™ Electric Pump System ***for NutriSphere-N® NH3 & Ag Leader***

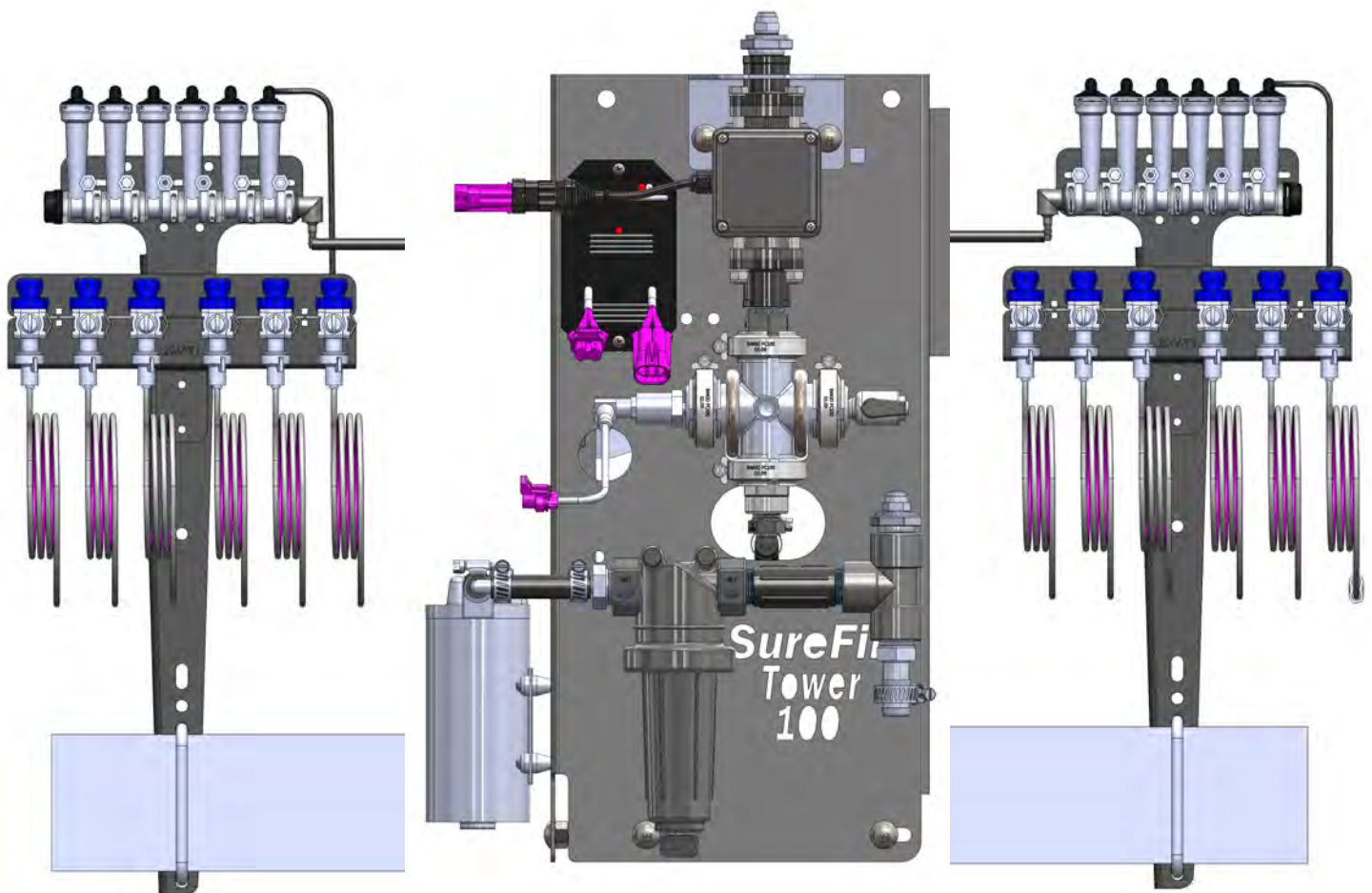

Table Of Contents

Introduction

- Read Me First2
- Basic Steps to Install your System.....3
- System Overview Drawing.....4

A

Introduction

Components - Liquid

- Flowmeter, Electric Shutoff and Section Valves5,6
- Pressure Sensor, Pump Priming and Air Bleed Valve7
- Flow Indicators and Manifolds8,9
- Dual Check Valve Systems, Metering Tube, Row Distribution.....9-11
- Shank and Knife Points11-12
- Toolbox (Spare Parts).....13

B

Components
Liquid

Components - Wiring & Electrical

- Connecting to Ag Leader Liquid Product Control Module 14-15
- System Layout..... 16
- PWM EPD..... 17
- Wiring Harness Drawings 18-20

D

Components
Wiring & Elec.

Installation Overview

- Tower 100 Plumbing Overview and Valve Operation, Recirculation..21
- Tower 100 Plumbing Detail.....22
- Tower 100 Tank Cradle and Mounting Brackets.....23

E

Installation
Overview

Controller Setup & Operation

- Ag Leader Liquid Product Control Module Setup 24
- Calibrate Pressure Sensor, Controller & Control Valve Settings..... 25
- Product and Rate Setup 26
- Device Information and Diagnostics 27
- Map Screen Product Control Toolbox..... 28
- Initial Operation Tests—Manual and Auto Operation..... 29-30

F

Setup &
Operation

Troubleshooting

- Pump Will Not Run..... 31-32
- Section Valves Will Not Move 32
- Application Rate fluctuates..... 33
- Slow Getting to Target Rate, No Flow Reading 33
- Speed/Flow Table 34

G

Trouble-
Shooting

Maintenance & Parts

- Winterization and Maintenance Recommendations 35
- Pre-season Service 35

H

Maintenance
& Parts

©2015 SureFire Ag Systems

Read Me First

The SureFire *Catalyst™* system is designed to give accurate and even row-to-row distribution of NutriSphere-N NH3 at a normal rate of 32 oz/acre. It has the capacity to deliver higher rates if desired.

Note: Ounces/acre, not gallons/acre.

On the Ag Leader display, the flowmeter will be calibrated to measure this product in ounces, not in gallons.

Ounces per acre means a very small amount of liquid is being pumped and distributed. At 6 mph on 30" row spacing, a rate of 32 oz/acre means that each row has a flow of just under 1 oz/min. On a 12-row implement, the total amount being pumped, therefore, is less than 12 oz/min. The SureFire *Catalyst™* system is engineered to accurately and evenly distribute this flow.

Low Flow Electromagnetic Flowmeter

The SureFire *Catalyst™* system utilizes an electromagnetic flowmeter (with no moving parts) that is designed and built to accurately measure flows down to 10 oz/min. (The flowmeter is rated down to 10 oz/min.) SureFire has proven the reliability and accuracy of the electromagnetic flowmeter by years of use in the field with thousands of flowmeters.

Dual Metering Tube Distribution

The low flow to each row will be evenly distributed through metering tubes that have openings of 0.060" and 0.080" in diameter. An orifice that could distribute this flow would be 0.015" or less in diameter. An orifice of that size is easy to plug. The 4 to 5 times larger diameter of the tube greatly reduces the risks of plugging.

The use of two tubes to each row (dual tube system) means that this system has the ability to handle a wide variation of rates and speeds (from 5 to 10 mph) and to do this under a wide range of temperature changes where the viscosity of the product changes.

Flow Indicators

The flow for each row will pass through a flow indicator that has a ball that will float to indicate flow to that row. This will give an immediate visual indication of flow to each row. While the flow indicators give a good indication of the flow to each row, they are not always an indicator of the exact flow to each row. Only a catch test will verify the evenness of the row-to-row distribution.

Tool Box

Each *Catalyst™* system comes with a built-in tool box that contains mission-critical spare parts to reduce equipment downtime.

Product Tank

The *Catalyst™* comes with either a 55 gallon or a 110 gallon tank. The large tank would allow over 400 acres of application at the 32 oz/acre rate.

Rinse Tank

Each system comes with a 3-gallon rinse tank that can be filled with RV anti-freeze to allow the system to be flushed when it will not be used for a few days and to be protected from freezing after the rinse.

Electric Section Valves

Implements that are 60' wide or wider can be split into 2 sections to allow section control. (*Note: Due to the low flow rates with this product, on a 20' wide section flow control may be erratic under 6.5 mph at the 32 oz/acre rate.*) Standard single section setups are equipped with electric row-shutoff valves on each row that will allow the pump to continue running when application stops at the end of the field to allow for a quicker return to Target Rate when application resumes. Two-section systems will have the same individual row shutoff valves but can be configured so the valves on the left half of the implement will function as Section 1 and the valves on the right half as Section 2.



Getting Started

A

Introduction

This manual contains the information for the SureFire Tower 100 *Catalyst* system for NutriSphere-N NH3 that is being introduced in 2015.

Changes to components or configuration settings may be made to improve the operation of the system.

Go to Section F for the instructions on setting up your display.

General Information

You have purchased a SureFire NutriSphere NH3 application system for your equipment. This system can be controlled by:

- John Deere Rate Controller
- Ag Leader Liquid Product Control Module
- Trimble Field-IQ Rate and Section Control Module
- Case IH Pro 700 with AccuControl
- SureFire Commander II controller

Note: SureFire Ag Systems also has the SureFire Torpedo system, a complete anhydrous ammonia application system. See www.surefireag.com for more information.

Basic Installation Steps

1. Have your control module and display in the cab connected and set up by the dealer for your display and controller. *To apply anhydrous ammonia and NutriSphere-N NH3 you will need 2 Liquid Product Control Modules, one for the anhydrous ammonia and one for the NutriSphere-N NH3.*
2. Open the packages and familiarize yourself with the components. See the System Overview Examples on the following pages to see the big picture of how SureFire systems are installed. Refer to manual sections B & D for component information.
3. Mount the Tower and tank on your equipment.
4. Install the plumbing kit including flow indicator columns, dual check valves, and metering tube plumbing to each row unit delivery point. See section B for information on these components.
5. Attach harnesses as shown in Section D.
6. Setup Controller for SureFire system as shown in Section F.
7. Fill system with water, conduct initial operation and tests per Section F.
8. Winterize system with RV Antifreeze if freezing temperatures are expected.



System Overview

A

Introduction

The following gives a layout of the SureFire Tower 100 *Catalyst* system with these components:

- Controller display in cab (Ag Leader Integra)
- Ag Leader Liquid Product Control Module
- Tower 100
- Flow Indicators
- Dual check valves with purple and gray metering tube

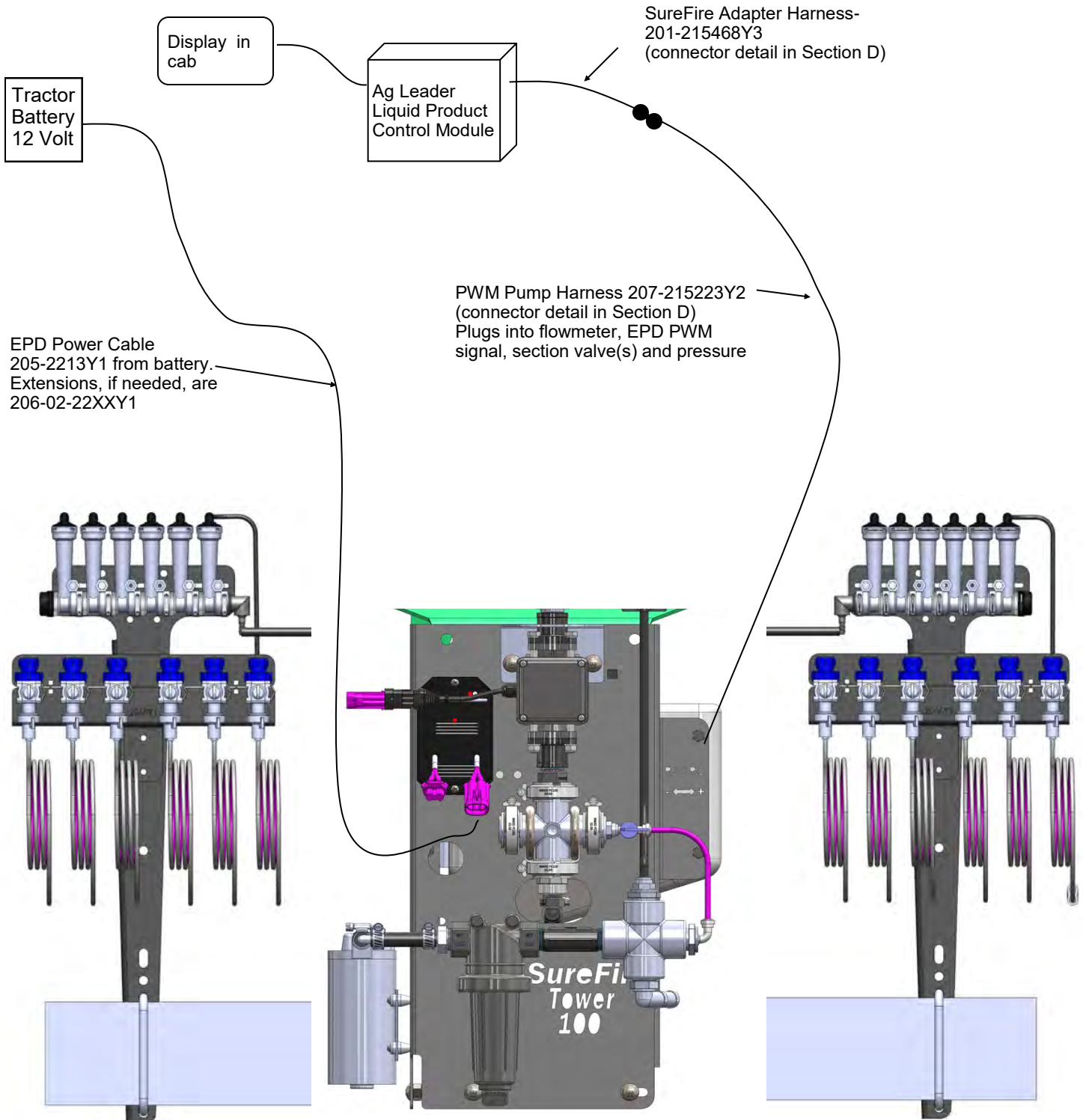

Electromagnetic Flowmeter

204-01-4621CUF05
0.08 to 1.6 GPM (10 oz/min to 205 oz/min)

B

Components
Liquid

Mounting Bracket,
Used in Tower 100
410-2106Y1-BK

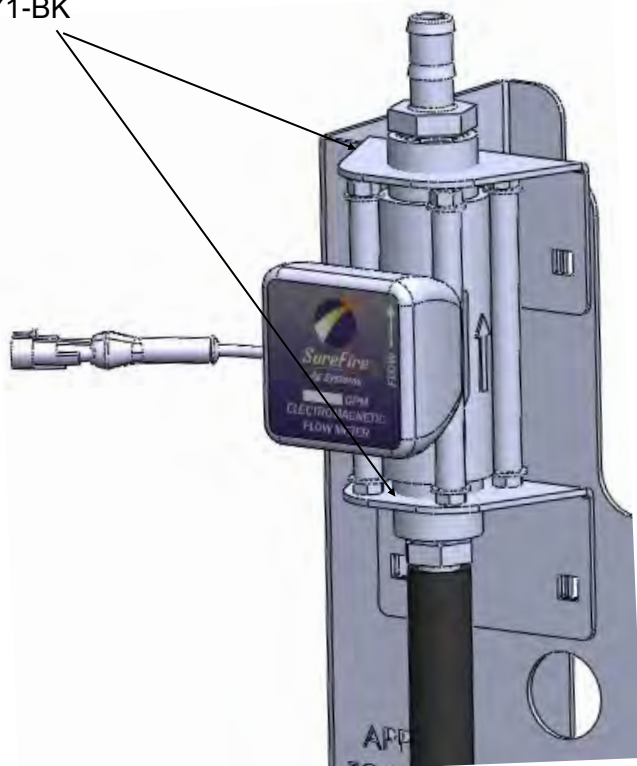

Electromagnetic flowmeters are superior to traditional turbine flowmeters in two basic ways. First, they have no moving parts. This translates into no wear items or potential for contaminants to jam a spinning turbine.

Second, electromagnetic flowmeters detect the flow by electrically measuring the velocity of the liquid, which makes them independent of viscosity or density of the fluid measured. They are extremely accurate using the standard calibration number. SureFire still recommends you perform a catch test to verify the system is properly installed and configured.

This flowmeter is rated down to 10 oz/min, but will accurately measure flows down to 8 oz/min. Below that rate, the flowmeter may not give a continuous pulse output.

On the Ag Leader Integra, the flow cal number will be set at 22,710 pulses per gallon. The NutriSphere-N NH3 product can be set up to show fluid ounces on the Ag Leader display.

Caution: Before welding on the implement, disconnect the flowmeter or damage to the flowmeter electronics may occur.

Do not power wash the flowmeter. High pressure spray directed at the back edge of the face plate or at the wire connector may allow water into the flowmeter electronics.



Section Valves and Individual Row Shutoff Valves

B

Components
Liquid

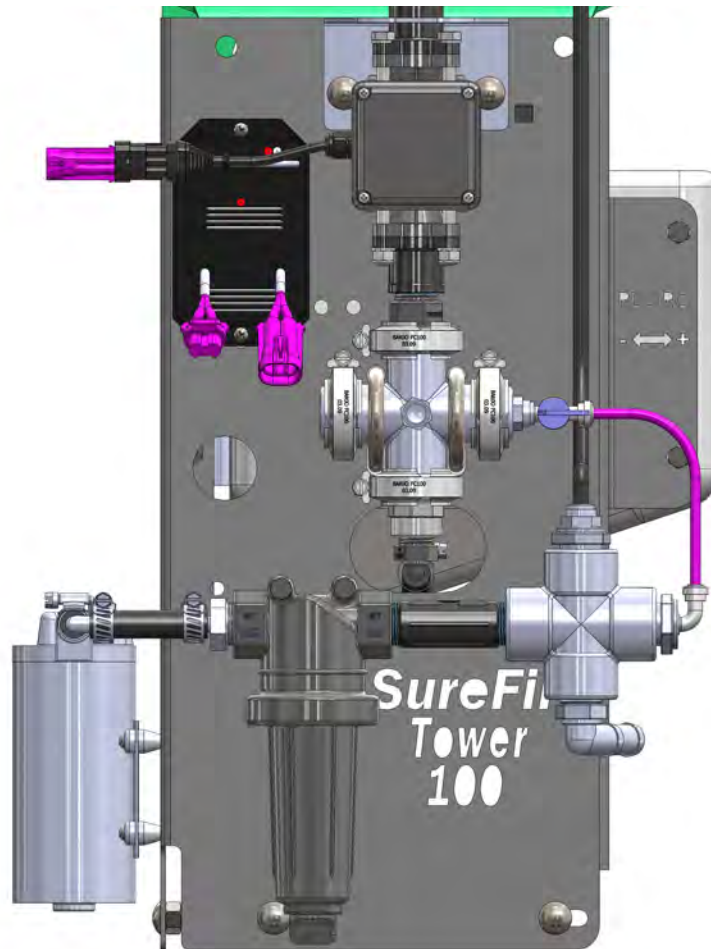

Individual row-shutoff Valves

Single-section systems will have individual electric row-shutoff valves that will shut off flow to the rows when application should stop, but allow the pump to continue running. This will help the system return to the Target Rate sooner when application resumes.

Section Control

Some systems (60 ft. and wider) may be set up as 2-section implements, so half of the applicator can be shut off in an overlap situation.

These systems will still have the individual row shutoff valves, but the valves on the left half of the machine will be plugged into the Section 1 connector on the harness and the valves on the right half of the machine will be plugged into the Section 2 connector.

Implements less than 60 feet wide need to be configured as one section for the NutriSphere N-NH₃ product, since the output for narrower sections will drop below the range of the flowmeter at lower speeds.

Wiring Connector:

Pin A—Red, 12 Volts +

Pin B—Black, Ground -

Pin C—White, Signal

12V=on ; 0V=off

Pressure Sensor

The Tower 100 comes equipped with a 0 to 5 volt 100 psi pressure sensor to work with your controller. This sensor for the Ag Leader system is a 3-wire type sensor. The Commander II uses a 2-wire sensor. The sensor has a 1/4" MPT fitting.

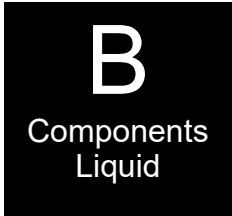

Your display will show the system pressure on the in cab screen. **The pressure reading is only for informational purposes and is NOT used in the flow control process.** Flow control uses the flowmeter feedback only.

The pressure sensor is very helpful to optimize system performance and troubleshoot any issues.

The pressure transducer is factory calibrated and will display a very accurate pressure reading on your display. No manual gauge is required.

When attaching connector to pressure sensor, make sure pins are aligned so they are not bent. When setting the Pressure Sensor calibration in the display, unplug the sensor so it will properly set the 0 point at 0.0 volts.

Pressure Sensor (3 wire type) with harness
521-05-050150

3-wire sensor
Pressure Calibration:
50 mv/psi

Pump Priming and Air Bleed Valve

An air bleed valve is included with each pump to aid in system priming. It is shipped in the pump accessories bag and must be installed during system installation.

Why use an air bleed valve:

Your system is equipped with a row shutoff valve on each row. These valves do not let air escape from the system. 12 volt liquid pumps are not good air compressors. Therefore, the pump can struggle to prime due to air trapped on the outlet side of the pump.

The air bleed valve is a small 1/4" valve that when opened lets air escape from the pump outlet at zero pressure. Open until liquid comes out and then close the valve.

How to install the air bleed valve:

Remove the 1/4" plug from the quick connect fitting on the center cross on the Tower (see picture). Next, insert the 1/4" tubing in the quick connect fitting. Run the 1/4" tubing to an easily accessible spot on your equipment. Next, cut the tubing and push the 1/4" valve onto the tubing. Finally, run the tubing to a low location where any product that escapes will run on the ground.

Be sure the air bleed valve tube does not become plugged with dirt or it will not allow air to bleed.

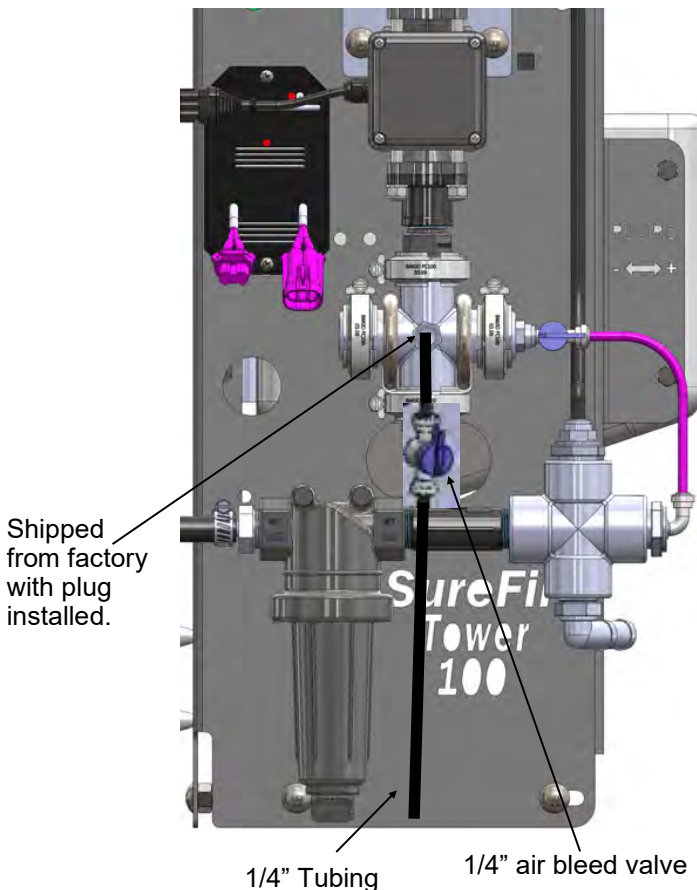

Product Distribution

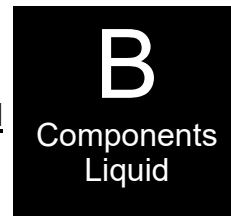

To assure proper and even distribution to each row, the product being applied must be metered to each individual row. This metering is done by using metering tubes which create back pressure so an equal amount of liquid is applied to each row.

Floating Ball Flow Indicator & Manifold System

Flow indicators give a clear visual signal that liquid product is flowing to each row. These indicators use an o-ring and wire clip connection to snap together in any configuration necessary.

The flow for each row will pass through a flow indicator that has one or two balls that will float to indicate flow to that row. This will give an immediate visual indication of flow to each row. While the flow indicators give a good indication of the flow to each row, they are not always an indicator of the exact flow to each row. Only a catch test will verify the evenness of the row-to-row distribution.

For most applications of NutriSphere-N NH3 at 32 oz/ acre, the Green Plastic ball gives a good flow indication. If a heavier ball is needed, use the Red ball.

On this low-flow system, the flow appears to be more stable if only one ball is used.



Parts List

Complete Columns

701-20460-920-GR-V Single Low Flow Column with 1/4" QC - 90 Degree Outlet

Fittings

701-20516-00 ORS x 1/4" QC - 90 Degree

701-20521-00 Wilger End Cap
701-20523-00 ORS Male x ORS Female x 3/8" FPT - Isolator
701-20525-00 ORS Male x ORS Male x 1" FPT - Tee

Service Parts Only

701-20470-00 Low Flow Column
701-20460-04 Wilger Lock U-clip
701-20460-05 Flow Indicator Ball - 1/2" SS Ball
701-20460-06 Flow Indicator Ball - Maroon Glass
701-20460-07 Flow Indicator Ball - Red Celcon
701-20460-08 Flow Indicator Ball - Green Poly
701-20460-09 Flow Indicator Ball - Black Poly
701-20460-15 Viton O-Ring for column & fittings
701-40225-05 Viton O-Ring for Orifice

Brackets & U-Bolts

400-1037A1 3-6 Row Bracket
400-1036A2 7-12 Row Bracket
400-2011A1 White Backer Plate for 3-6 Row Bracket
400-2010A1 White Backer Plate for 7-12 Row Bracket
400-1315A2 Flow Indicator Bracket, 6-8 in wide hitch mount



Flow Indicators and Dual Check Valves

B
Components
Liquid

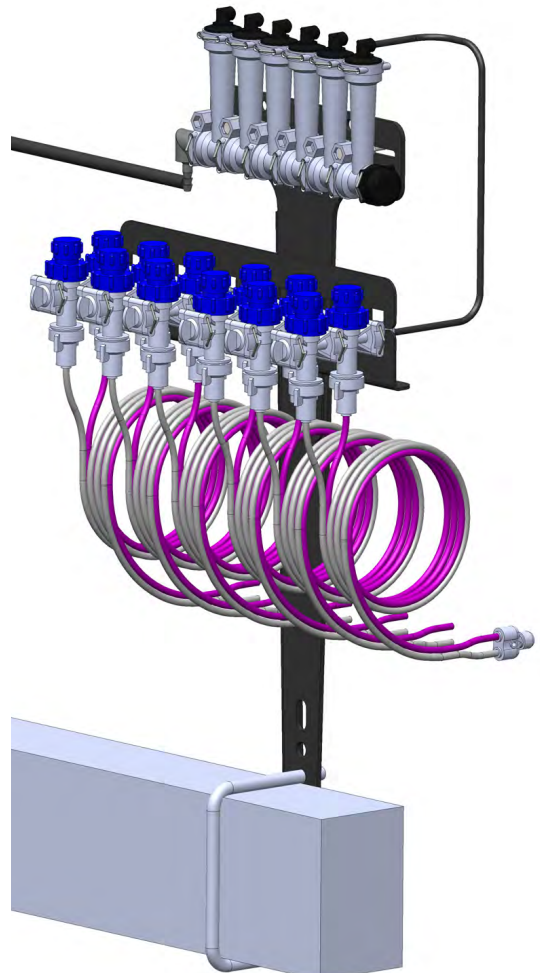

Ball retainer—If top is removed, be sure that the ball retainer is in place when top is reinstalled.

Assembly of top of flow indicator tube

Low Flow Column (mostly 1/4" QC)

The low flow column has a smaller internal diameter. This means a heavier ball can be used to monitor a smaller flow.

Externally, the low flow column can only be identified by "Low Flow" molded into one side of the column. All the same fittings work with low flow and full flow columns.

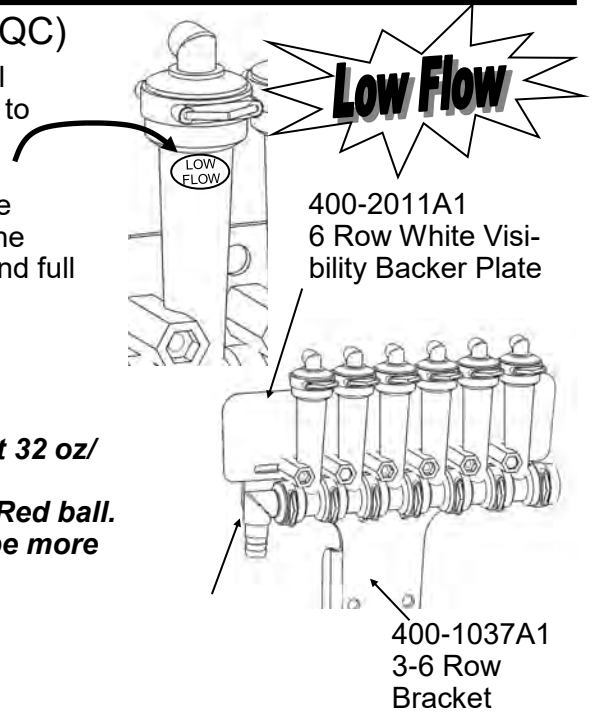

Floating Balls

For most applications of NutriSphere-N NH3 at 32 oz/acre, the Green Plastic ball gives a good flow indication. If a heavier ball is needed, use the Red ball. On this low-flow system, the flow appears to be more stable if only one ball is used.



Dual Metering Tube Plumbing Kits with Dual Check Valve

B

Components
Liquid

The SureFire *Catalyst* Tower 100 NutriSphere-N NH₃ system comes with a dual metering tube distribution system. These plumbing kits will contain everything you need to distribute product from the flowmeter outlet down to the ground application device.

The dual check valve assembly is a key piece in the dual metering tube design. In addition to a check valve to stop product from draining when the system is shut off, each check valve has an on/off valve on top of it. These on / off valves allow the operator to turn on only tube 1, only tube 2, or both tube 1 and 2. This provides for three different application ranges, which is especially helpful when using a liquid which has a variable viscosity based on temperature changes.

Dual Advantage of Dual Metering Tube

Metering tube provides a larger passage way diameter than a comparable orifice. Typical NutriSphere-N NH₃ applications apply around 1 to 1.5 oz/min/row. An orifice for this rate would have a 0.015" diameter opening. The SureFire system uses metering tubes with diameters of 0.060" and 0.080". This 12' tube with more than twice the diameter creates a system resistant to plugging while providing excellent row to row distribution.

By using two metering tubes, the system can provide the proper system pressure as the product properties change due to temperature, mixtures and other factors.

○ Not actual size ⊗ 2x

Standard Orifice

Metering Tube

Field Operation of Dual Metering Tube - Dual Check Valve System

The dual metering tube allows for three application rate ranges.

Therefore, based on temperature, tank mixing and product batch, the best tube to use will change.

SureFire recommends you start with the Purple tube ON only. This is the middle size and is a good starting point. Conduct a test using the Nozzle Flow Check to determine your system pressure. Recommended pressure is between 10-40 PSI. If pressure is less than 8 psi, some check valves may not open and row to row distribution may be uneven.

Start with Purple tube ON, gray tube OFF:

- **Pressure below 10 PSI:** Turn purple tube OFF and gray tube ON.
- **Pressure over 30 PSI:** Turn BOTH purple and gray ON.

This low-flow system shows a more stable flow at lower pressure. Use the largest tube or combination of tubes that will maintain pressure at 10 PSI or higher.

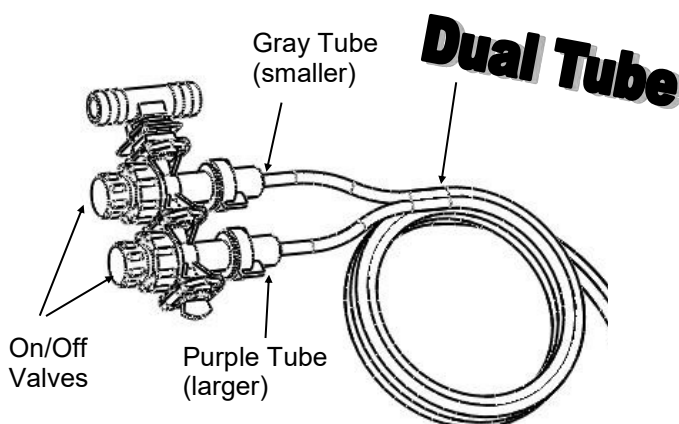

Note: Flow tests with water will have very different pressure readings than what the system will have with NutriSphere-N. The pressure will be much less with water for a given flow than with NutriSphere-N.

Dual Metering Tube and Manual On/Off Check Valve

Each row has a gray tube and a purple tube. The tube to use will depend on the rate, speed, and viscosity of the product. The viscosity of the product will change with temperature.

Gray tube 0.060" diameter
 Purple tube 0.080" diameter
 Tubes are cut to 12' long.

Each tube is connected to a manual on/off 4 lb check valve. To turn a tube on, twist the blue top of the check valve CCW. To turn a tube off, twist the blue top CW.

The system operates best at lower pressure. Use the largest tube or combination of tubes that will maintain pressure at 10 PSI or higher.

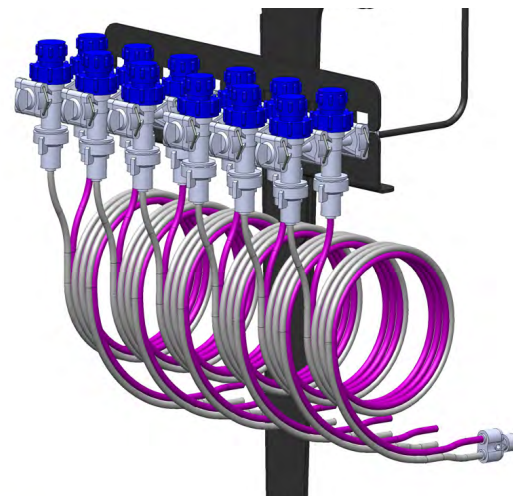

Connection to Shank

(See next page for pictures and more information on shanks and knives. Many other options are available to connect to the shank, depending on the implement setup.)

1. Push the end of the purple and gray tubes for each row into a 1/4" x 1/4" x 1/4" Y.
2. Cut a piece of black 1/4 " tubing to the length needed to deliver the product to the bottom of the shank.
3. Push this piece of standard 1/4" black tubing into the Y fitting.
4. Slide a 24" length of 3/8" hose over the end of the black tube. Push the black 1/4" tube inside the tube on the shank and push it as near the exit hole on the shank as possible.
5. Clamp the end of the 3/8" hose to the top of the delivery tube on the shank. This hose will act as a protector for the 1/4" tube.
6. Zip tie securely in as many places as possible.

Purple and gray tube to 1/4" QC Y to black 1/4" tube to liquid tube on shank:

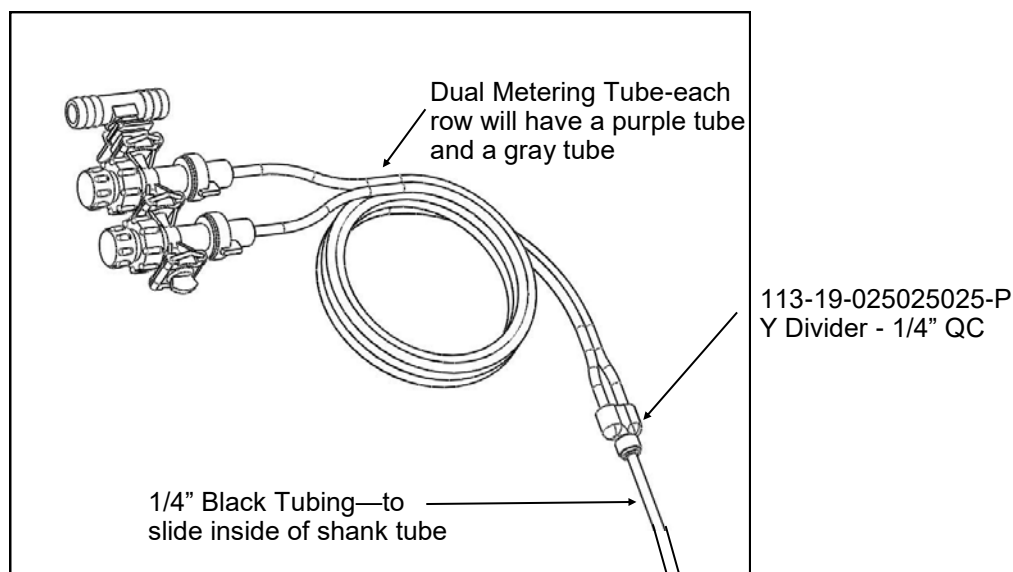

Shanks and Knife Points available from SureFire Ag Systems

SureFire Ag Systems and Verdesian have worked closely with an established shank manufacturer to develop a shank and two knife points that will deliver the anhydrous ammonia and NutriSphere-N NH₃ where it needs to go. They will be able to advise users on the best setup for their application scenario.



The knife on the left is for no-till conditions. On the right is a less aggressive point for tilled soil.

Anhydrous tube

NutriSphere tube

Insert a piece of black 1/4" tube inside the NutriSphere tube and push it down so the end of the black tube is at the top of the outlet hole. (See instructions on previous page.)

To protect the black 1/4" tube, slide a 2-foot long piece of 3/8" hose over the black tube and clamp this hose to the top of the NutriSphere tube.

Your application setup may be different. Generally, insert the black 1/4" tube into the tube through which the NutriSphere-N NH₃ will be applied.

On NutriSphere placement tubes that are open on the bottom, a slightly higher velocity stream may be achieved by using a 30-36" piece of purple tube as the final discharge tube. Insert this purple tube inside the NutriSphere placement tube and push it to the bottom of the tube. If the purple tube is used, the length of this tube should be the same on all rows.



Toolbox (no tools, just spare parts)

B

Components
Liquid

A toolbox containing critical items will be included with each system. The toolbox will contain:

QTY

- 1 12 volt electric pump
- 2 flow indicator columns
- 2 dual check valves
- 2 Y dividers-1/4 x 1/4 x1/4
- 2 1/4" QC couplers
- 10 size 6 hose clamps
- 1 3/8" HB 90 degree electric pump fitting
- 1 3/8" HB straight electric pump fitting
- 2 40 Amp fuses
- 1 1" Tee Strainer gasket-FKM
- 2 Clips for electric pump



Ag Leader Liquid Product Control Module



The SureFire Catalyst System begins at the Ag Leader Liquid Product Control Module. The picture below shows this control module. You will need to purchase this module from your Ag Leader dealer. You will need one module to control the anhydrous application and another module to control the NutriSphere-N NH3 product.

The rate controller has four harness connections. The function of each connection is labeled in the picture below and on the next page. The following pages show a system diagram for single section configuration. Detailed harness drawings follow for information and troubleshooting.

Instructions for setting up the Ag Leader in cab display are in Section F. Detailed screen shots of the display are included showing exactly what settings are required and recommended for the SureFire Catalyst System.

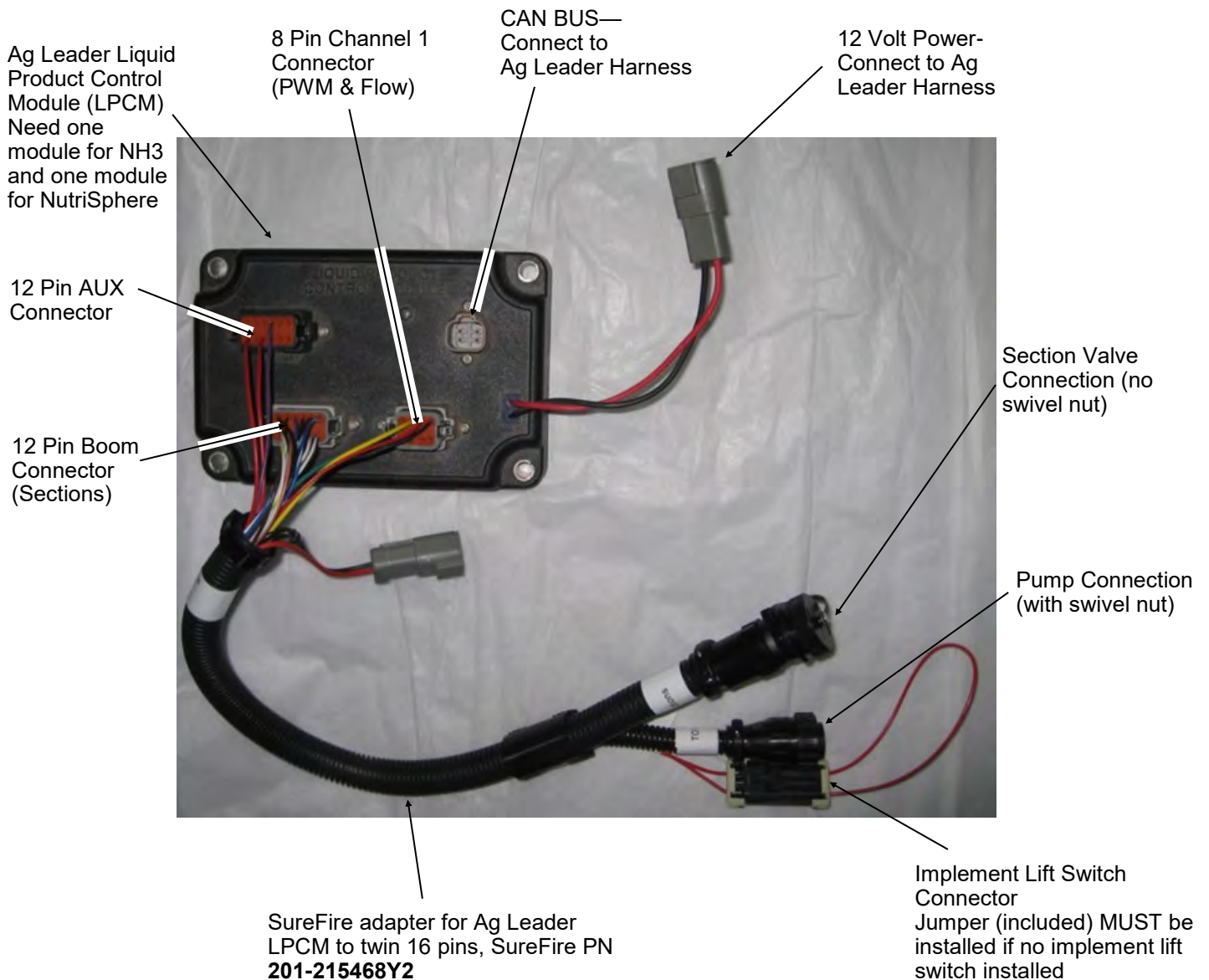

Ag Leader Liquid Product Control Module



This chart shows you the output functions by pin location on the Ag Leader Liquid Product Control Module. Use this information to verify if the Ag Leader system is providing the correct output. If the module is not providing the correct output, contact your Ag Leader dealer to repair the problem. Also review any applicable settings on the display to verify the system is properly set up.

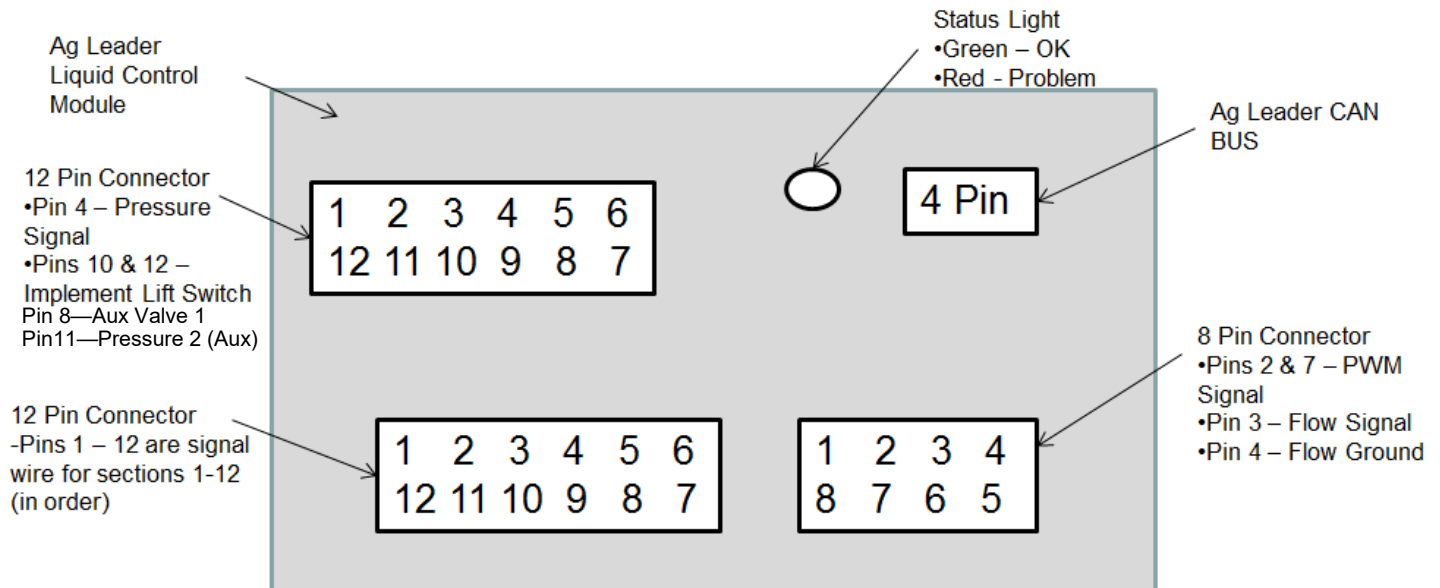

Common Troubleshooting:

PWM Signal to Pump: Pin 2 to 7 should have 0-12 volts to turn pump on. Use manual mode to increase signal. Should get up to 12 volts after holding increase button.

Flow meter Tap Test: Pins 4 and 3 are Flow Ground and Signal. If no flow is registering on the display, you can tap between these two pins with a short wire. This produces a pulse. The display should indicate a flow when this is done rapidly.

Tower & Ag Leader Control Layout

Control: PWM EPD

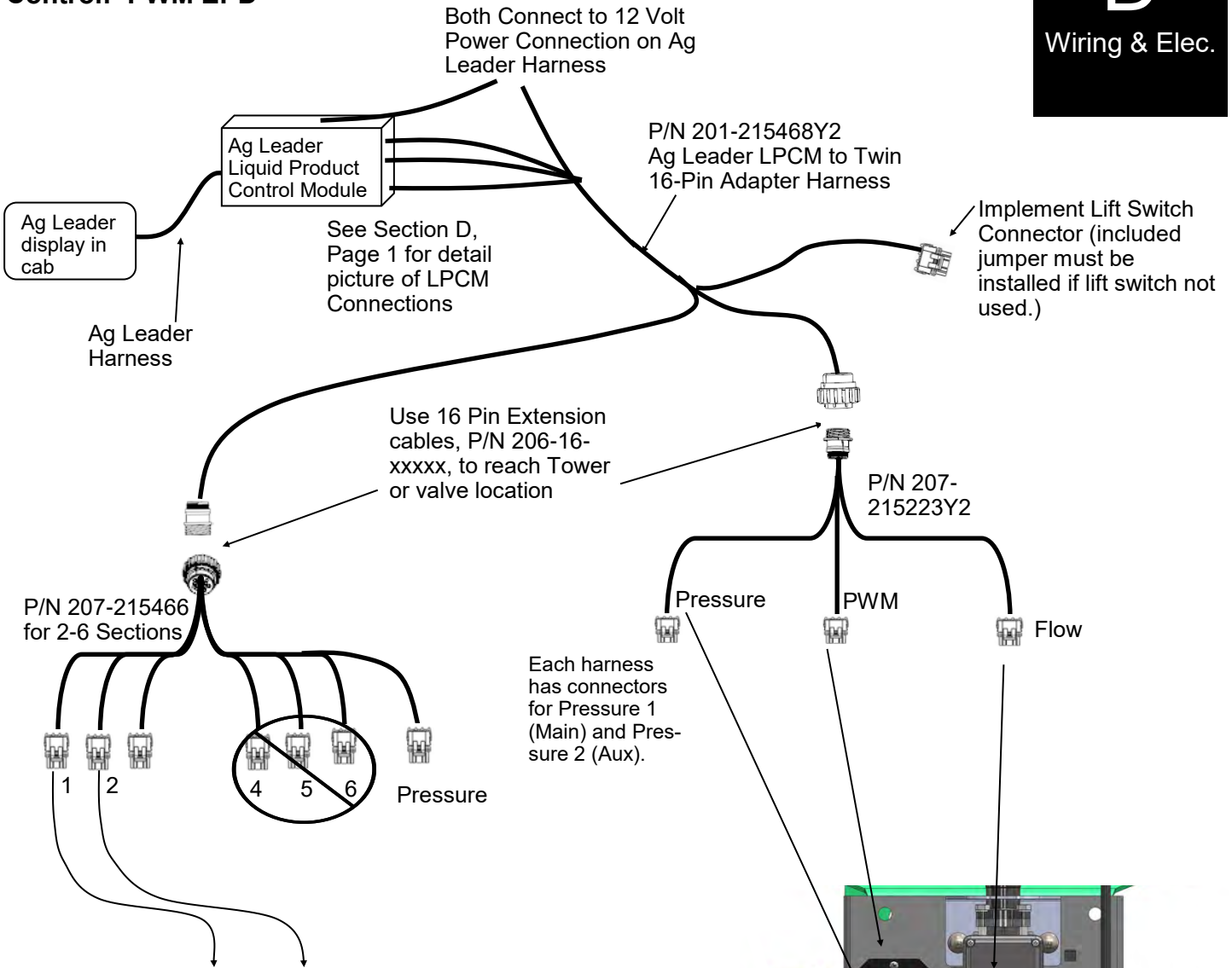

If using two section valves you will connect Sections 1 and 2. (Implements less than 60' wide will be configured as 1 section.)

Can use 3-Pin Weatherpack Extension cables to reach section valves if needed.

If implement is set up with just one section, you will use the Section 1 connector to connect to the Row Shutoff valves. This will shut off flow to the rows so the pump can continue running when turning around at the end of the field. (See Section F for display setup instructions.)

 Means connector not used in this configuration.

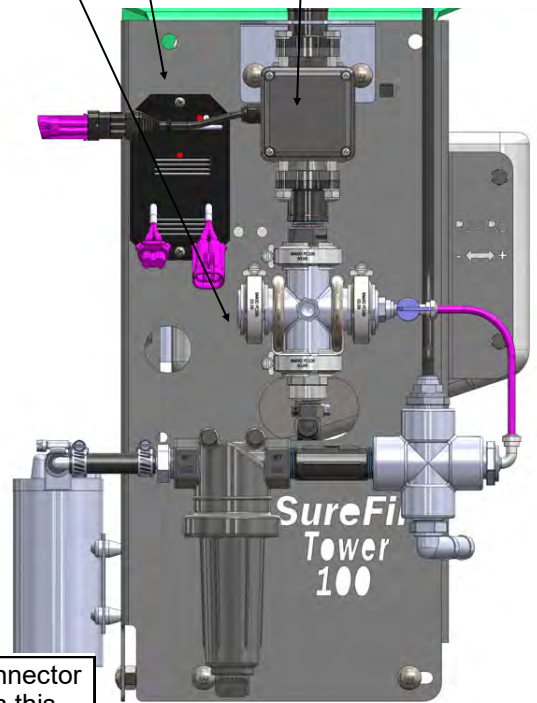

40 Amp PWM EPD (Pulse Width Modulated Electric Pump Driver) Item Number: 205-18385



The Electric Pump Driver powers the electric pump by providing a pulse width modulated signal to control pump speed. It needs to have a power connection and wiring capable of carrying up to 40 amps of current. **It must be connected directly to the tractor battery.** SureFire recommends 10 gauge (or heavier) wire if extending harnesses in the field.

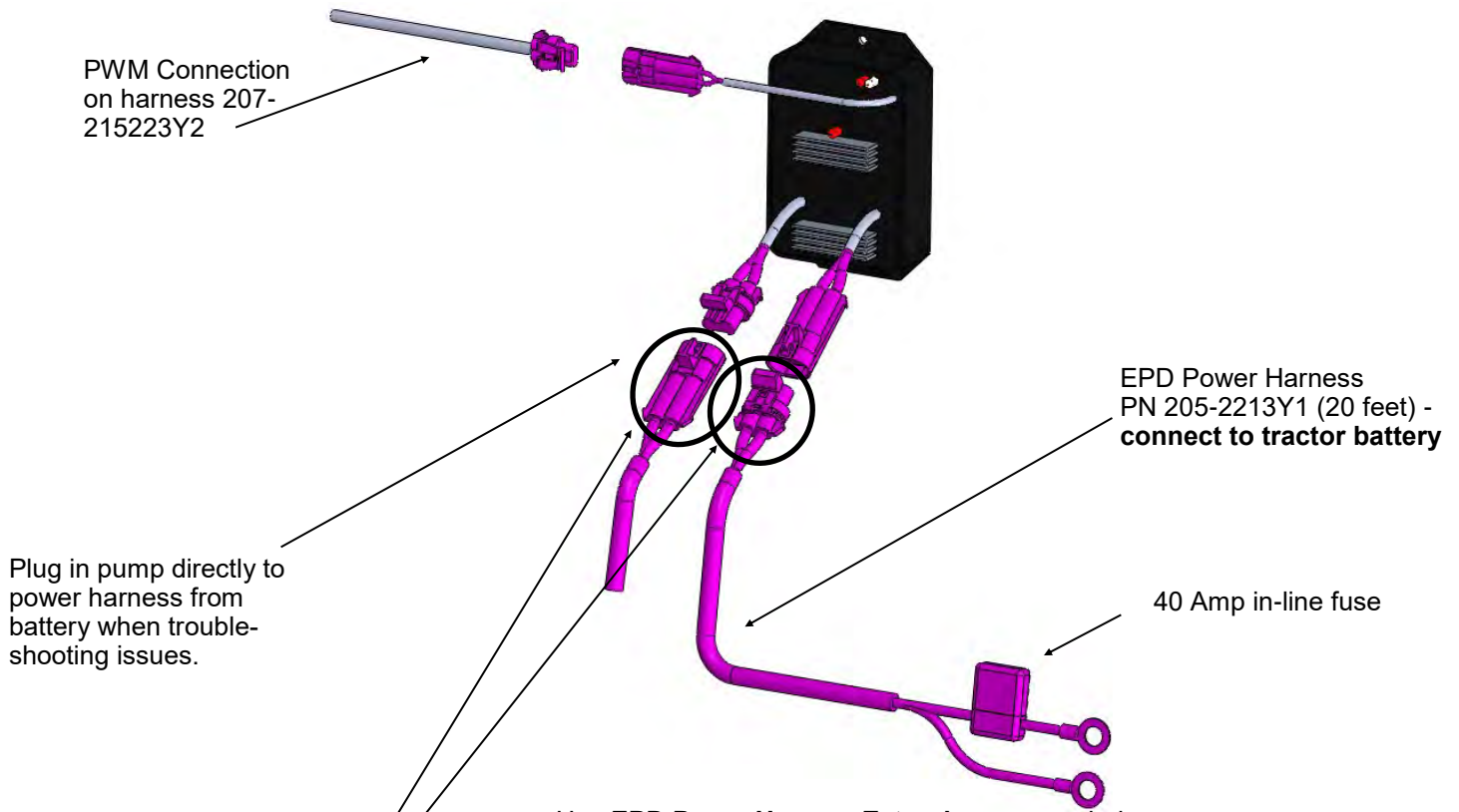

Plug in pump directly to power harness from battery when troubleshooting issues.

Troubleshooting Tip:
If the pump won't run, connect the power and pump connector directly together to give pump full 12 volts directly from battery. This will tell you if the pump is the problem or if something else is wrong. The pump will be running at full speed, so don't leave it connected this way for long.

Use EPD **Power Harness Extensions** as needed

(Ends of harnesses are 10 gauge wire with MP 480 Connectors)
Center section of harness

206-02-2205Y1	1' Extension	10 gauge
206-02-2206Y1	5' Extension	10 gauge
206-02-2207Y1	10' Extension	8 gauge
206-02-2208Y1	20' Extension	8 gauge
206-02-2209Y1	30' Extension	30' and longer—6 gauge
206-02-2210Y1	40' Extension	(for 16 row front fold)
206-02-2211Y1	60' Extension	(for 24 row front fold)

SureFire recommends a single long extension harness as multiple connectors will reduce voltage, increase current and hurt performance of your electric pump system.

Wire Size: 18 AWG unless otherwise specified

201-215468 Y3

Length: 2ft

Ag Leader Adapter Cable twin 16 Pins

12 Pin Boom Connector – Deutsch DT06-12S Female

Section 1	1
Section 2	2
Section 3	3
Section 4	4
Section 5	5
Section 6	6
Section 7	7
Section 8	8
Section 9	9
Section 10	10
Section 11	11
Section 12	12



12 Pin Aux Connector – Deutsch DT06-12S Female (Black Connector)

Agitation Pressure

1	
2	
3	
Pressure 1 (Main)	4
5	
6	
7	
Aux Valve 1	8
Aux Valve 2	9
Impl Switch Signal	10
Pressure 2 (AUX)	11
Impl Switch GND	12



8 Pin Channel 1 (PWM and Flow) Connector – Deutsch DT06-08S Female

1	
Servo +/-PWM	2
Flow Signal	3
Flow GND	4
5	
6	
Servo -/PWM	7
8	



2 Pin (Power In) Connector – Deutsch DTP04-2P Male



+12VDC	1
Ground	2

16 Pin Round – AMP Male pins in male body (with threads for swivel nut)

1	Valve GND
2	Section 2
3	Section 3
4	Section 4
5	Section 5
6	Section 6
7	Section 7
8	Section 8
9	Section 9
10	Section 10
11	Pressure 2(AUX)
12	Aux Valve 1
13	Pressure 1 (Main)
14	Valve Power
15	Section 1
16	Valve Power

Attach Dust cover to Connector

Labeled "Sections"



16 Pin Round – AMP Female pins in female body (with swivel nut)

1	GND
2	
3	Servo +/- PWM
4	Servo -/ PWM
5	
6	Section 1
7	Labeled "To Pump"
8	
9	Pressure 1 (Main)
10	Pressure 2 (AUX)
11	Flow GND
12	
13	Flow Signal
14	
15	Master On/Off
16	Power



Run/Hold



A	Signal
B	
C	GND



Signal	A	18 AWG Red
	B	
GND	C	



Project:	201-215468 Y3	Drawn By:	Albert Popp Rev. by Mark Wolters
Filename:	Ag Leader Adapter Cable twin 16 pins (2 Pressure and Aux Valve 1)	Date:	10/7/2011 Rev. 09/24/2013 01/13/2015
Copyright 2011-2015 SureFire Ag Systems		Page of Pages	1 of 2

207-215223 Y2

PWM Pump Cable – Flowmeter, PWM & 2 Pressure

Wire Size: 18 AWG

Length: 10ft

16 Pin Round – AMP
Male pins in male body
(with threads for swivel nut)

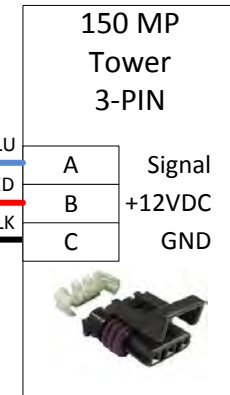
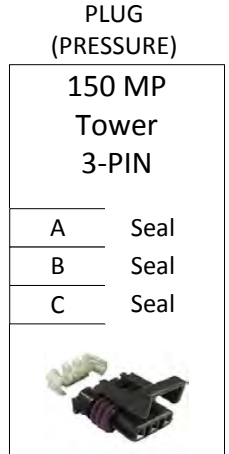
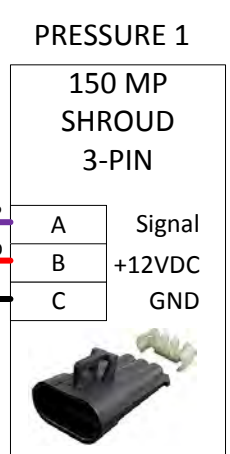

FLOW

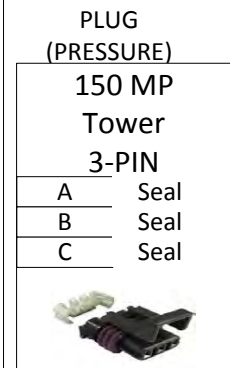
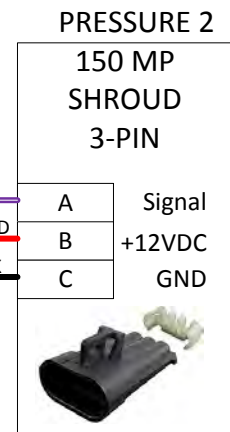

Project:	207-215223 Y2	Drawn By:	Brady Gragg Rev by Mark Wolters
Filename:	PWM Pump Cable – Flowmeter, PWM & Pressure	Date:	5/17/12 08/19/2013
Copyright 2012 SureFire Ag Systems		Page of Pages	1 of 1

207-215466 Y2

6 Section Boom Harness w/ 2 Pressure and Flow Return Valve

All wire gauge 18 AWG
Unless Specified

Wire Length: 10'

Put booms 1-6, Flow Return and Pressure 1-2 in one loom 10' long

Provide dust caps for WP and MP connectors

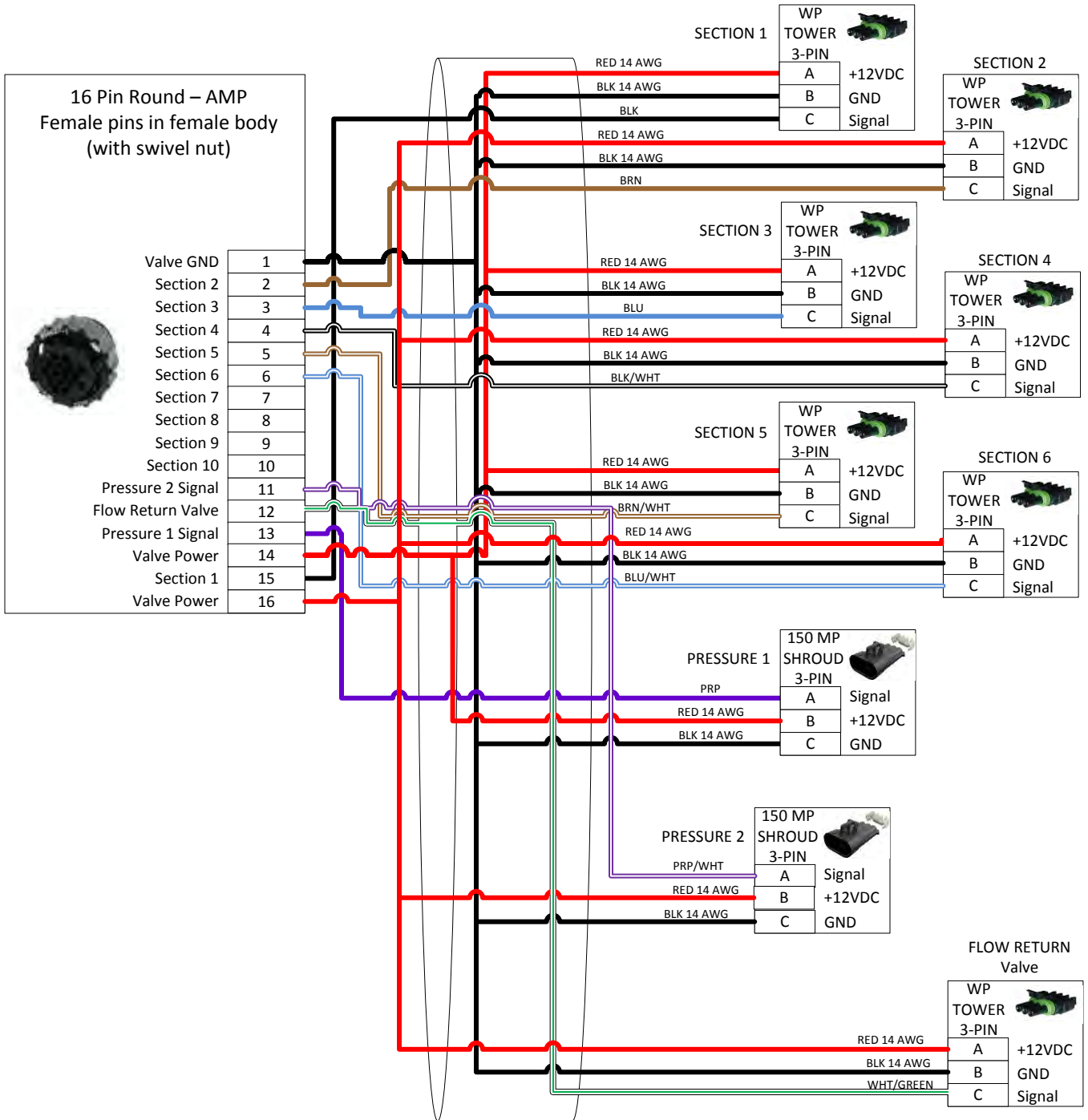

Project:	207-215466 Y2	Drawn By:	Dirk Ricker Rev. by Mark Walters
Filename:	6 Section Boom Harness w/ 2 Pressure and Flow Return	Date:	9/12/2012 08/20/2013
Copyright 2012-2013 SureFire Ag Systems		Page of Pages	1 of 1

Tower 100 *Catalyst* Plumbing Overview & Valve Operation

E

Installation
Overview

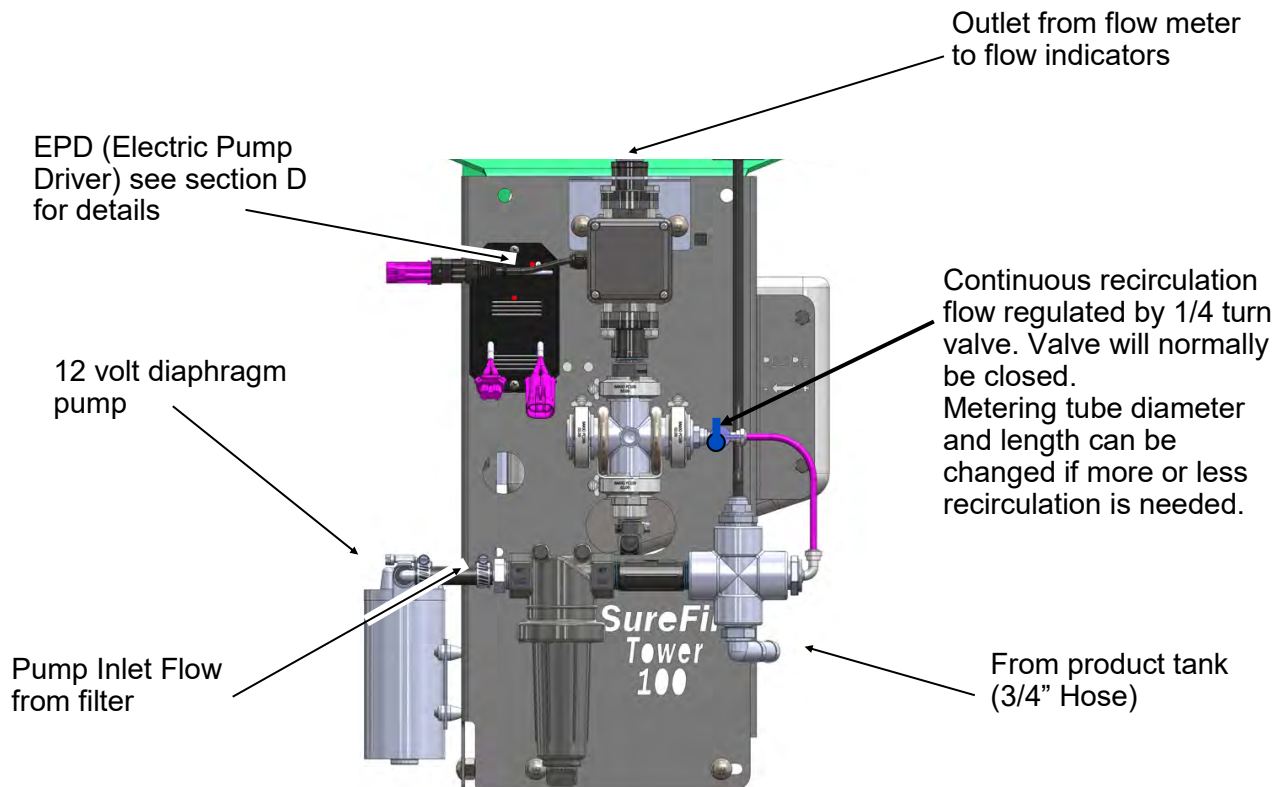

Do I need recirculation flow?

Recirculation flow allows the pump to run faster than if the total pump flow was applied to the ground. This may be helpful when operating at very low flow rates. This system will typically operate with the recirculation valve closed. The metering tube on the recirculation loop can be changed to allow for more or less recirculation. Too much recirculation can result in unstable flow reading on the display.

Tower 100 *Catalyst* Plumbing Detail

(Bottom of Product Tank)

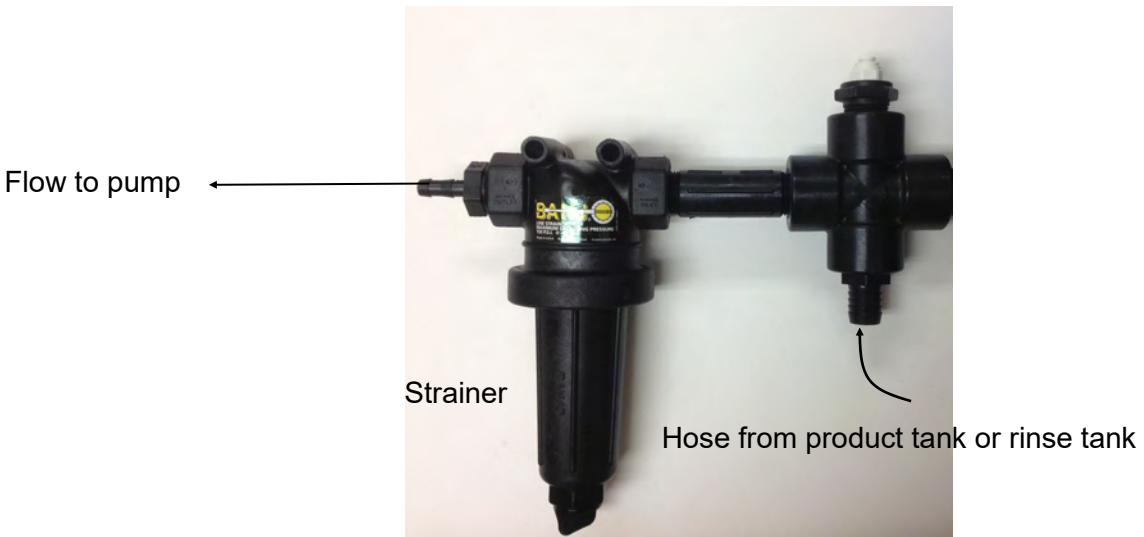
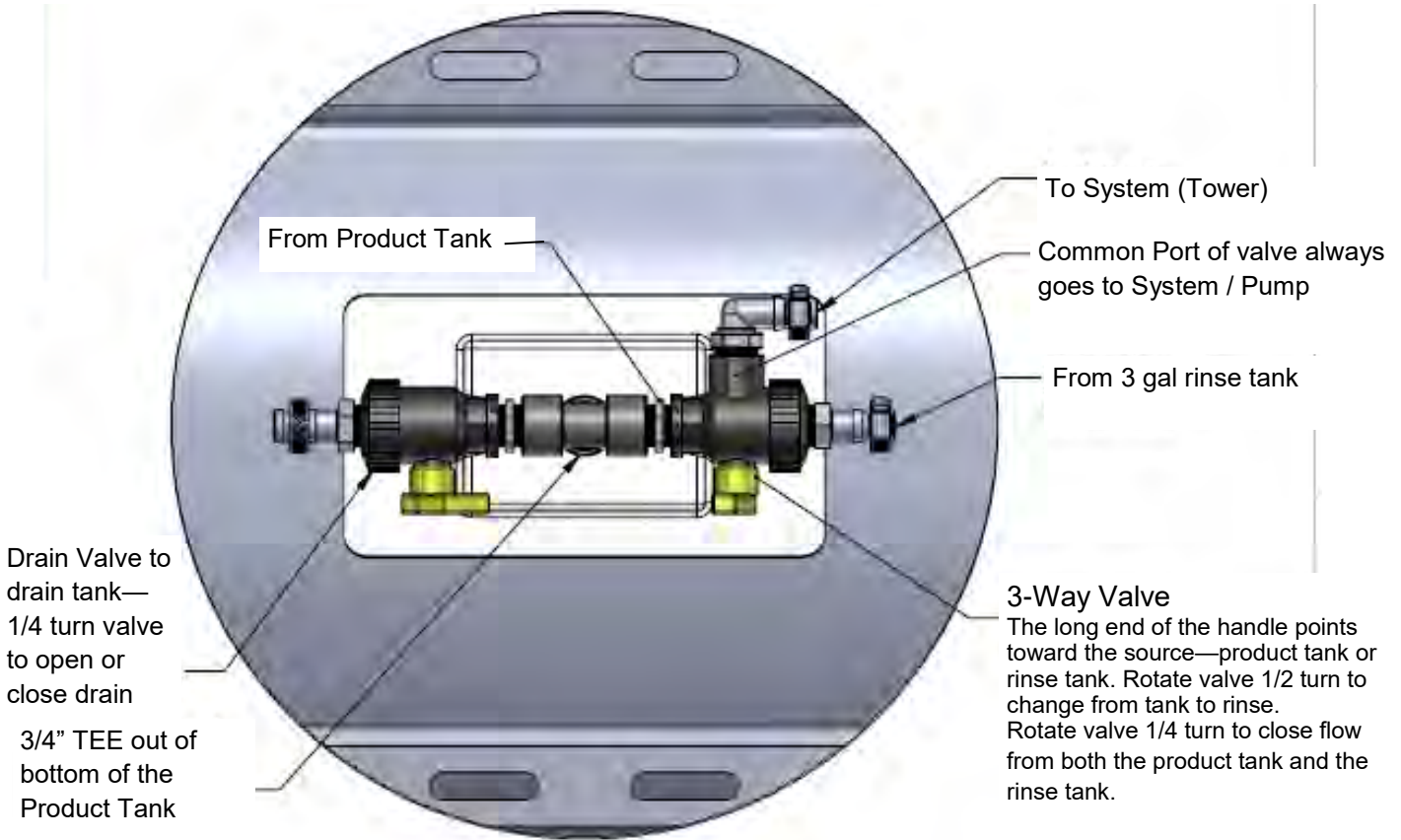

Tower 100 Mounting Options

E

Installation
Overview

Various brackets and u-bolts are available to provide a way to mount the Tower 100 to almost any implement.

Your SureFire configuration specialist will get your implement information at ordering time and make sure that all of the hardware needed for your system is included.

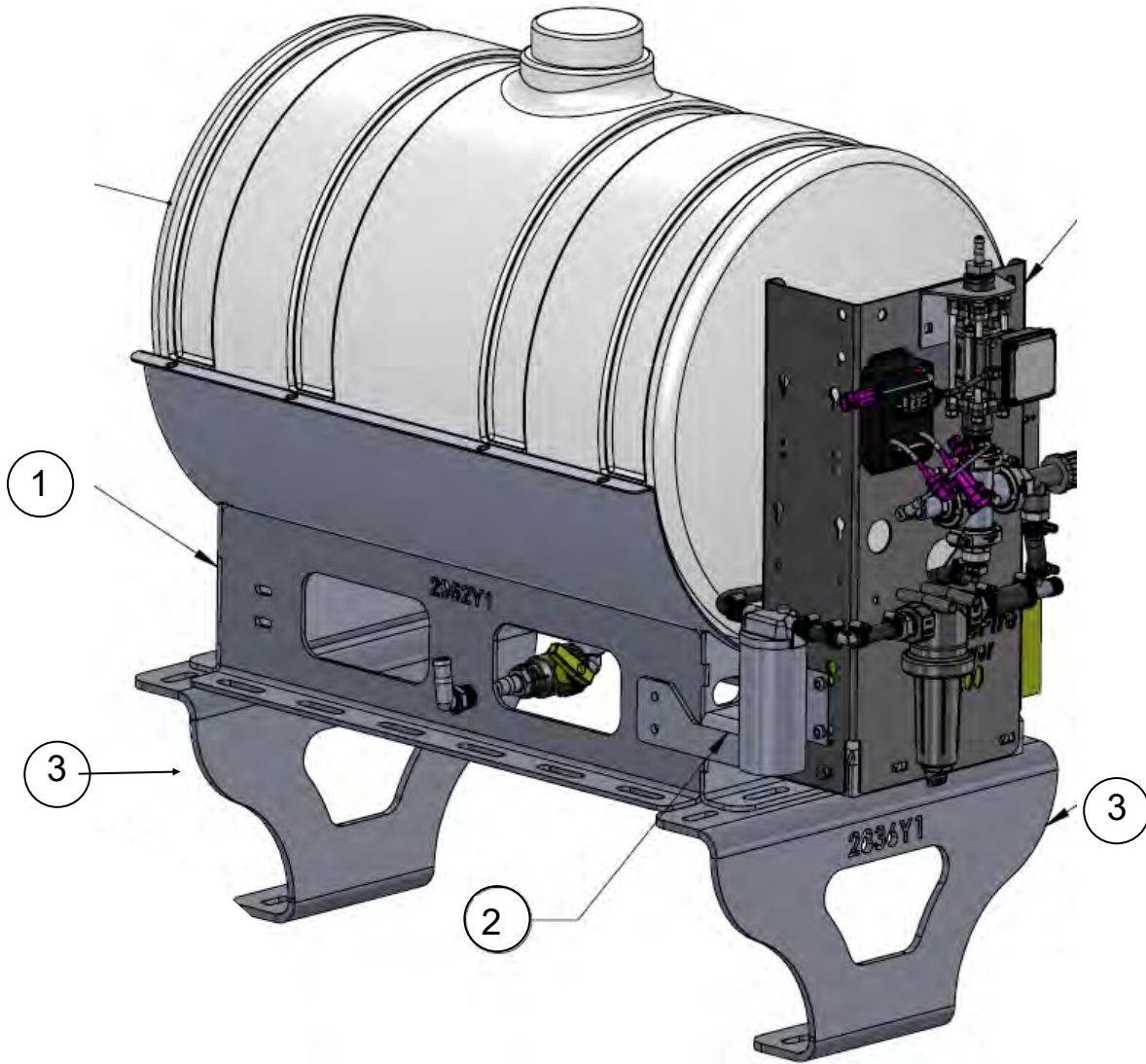

ITEM NO.	Part Number	Description	QTY
1	421-2952Y1	55 gal/24" DIA tank cradle	1
Or	421-2956Y1	110 gal tank cradle	1
2	420-2957Y1	Tower 100 Mount Bracket	1
3	420-2836Y1	Tank Stand (12" tall)	2
Or	420-2986Y1	Tank Stand (6" tall)	2

A variety of U-bolts are available to fit various sized bars.

Ag Leader Integra Setup

Ag Leader technology is a very flexible control platform with many capabilities. This section will show you the necessary steps to set up your Ag Leader display to control a SureFire Tower Catalyst System.

Follow the general directions in your Ag Leader Integra Operators Manual (esp. under Configuration and Liquid Rate Control). This manual will show you the specific numbers and settings to use with your SureFire Catalyst system.

For any particular application, the numbers may need to be adjusted in the field to optimize performance.

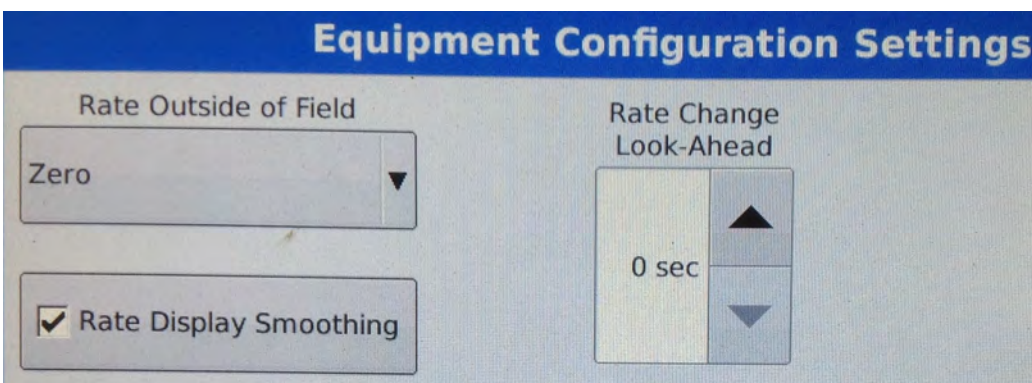
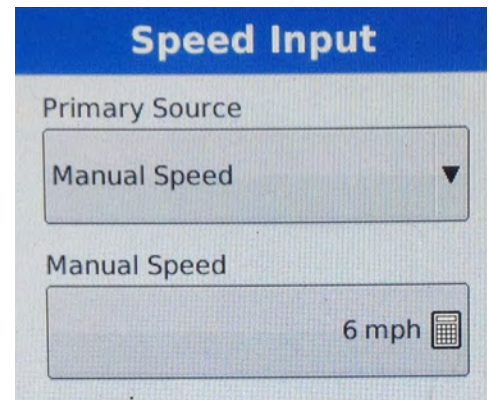
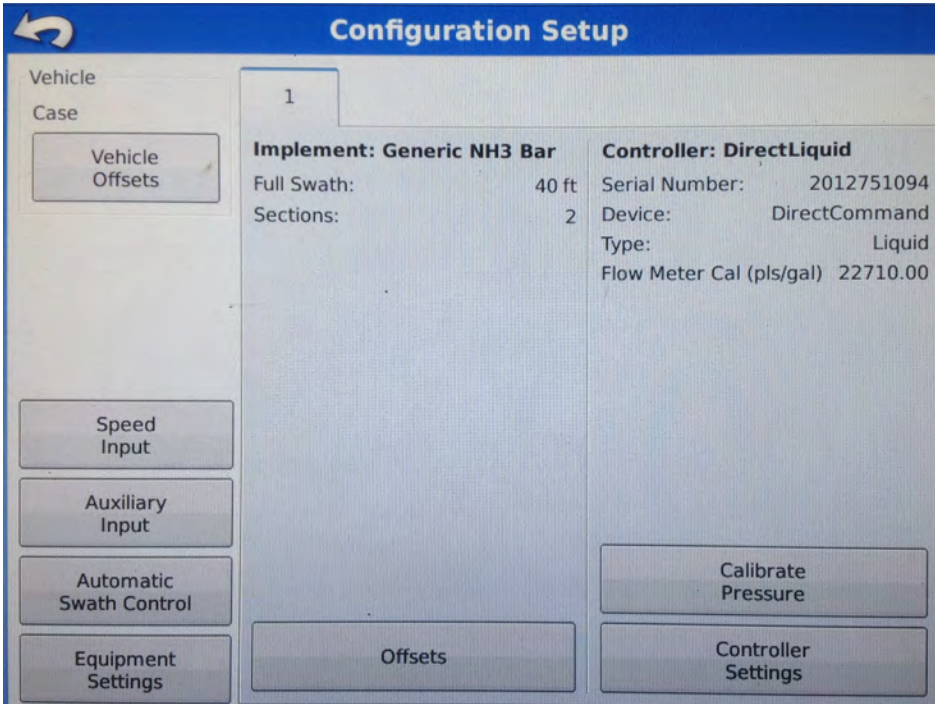

Setup -

F

Setup & Operation

Pressure Sensor Calibration: Step 1 of 3

Select Pressure to Calibrate

Main

Pressure Sensor Calibration: Step 2 of 3

Enter a Pressure value as a Set Point

0 PSI

Enter Voltage / Pressure Ratio

50.0 mV/PSI

Controller Settings

Flow Meter Calibration: 22710 pls/gal

Flow Control Delay: 3-4 sec

Control Valve Settings

Rate Off: Hold-pump continues to run, Close-pump shuts off

Auxiliary Valve 1: Close

Auxiliary Valve 2: Close

Rate Error Alarm Threshold: 30 %

Timeout: 30 s

Control Valve Settings

Control Valve: PWM 12 volt

PWM Frequency: 150

PWM Gain: 5000

PWM Standby: 15-25

Zero Flow Offset: 10

Allowable Error: 2 %

Controller and Control Valve Settings:

Rate Off Flow Control Valve-will be set at Hold for most setups so the pump will continue to run at the end of the row to achieve quicker return to Target Rate on return to the field.

PWM Gain-start at 5000. This can be increased to allow controller to adjust more quickly to speed or rate changes. If set too high, the system may not lock on to rate as well in normal operation across the field. (Adjust in increments of 1000.)

Allowable Error-Set at 2 or 3%. At 3%, the controller would not make any adjustments if the applied rate is between 31 and 33 oz/acre on a 32 oz/acre Target Rate.) If set too low, the controller may overreact to every small deviation from Target and actually end up with more deviation.

PWM Standby-This is the speed at which the pump will run at the end of the row when Flow Control Valve is set to Hold. Normally this will be between 15 and 25, just at or above the normal operating PWM Duty Cycle.

Zero Flow Offset-Start at 10. This sets the minimum PWM Duty Cycle at which the pump will run. If this is too high, the pump may not be able to slow down enough at low speeds. If set too low, the pump takes longer to reach operating speed on first startup.

Flow Control Delay-Set this at 3-4 sec to allow system to start up without the controller chasing the rate up and down when flow first starts or resumes.

Timeout-Set to 30 sec when first starting system or when Troubleshooting. Can be set lower during normal operation.

Setup - System

F

Setup & Operation

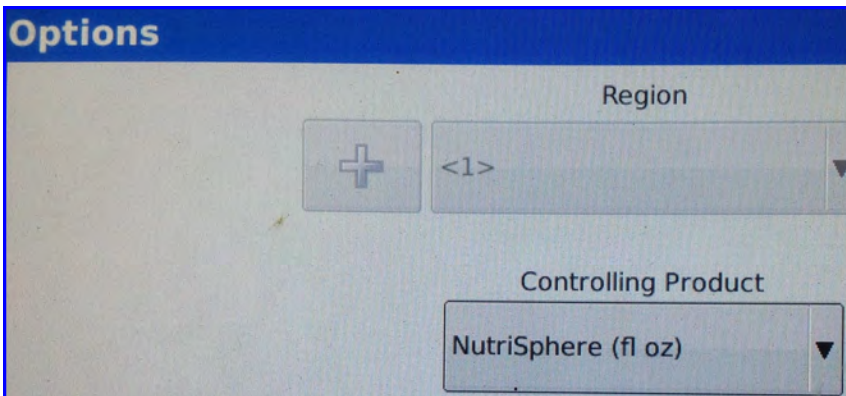

In normal operation, set the NutriSphere N-NH3 product to measure in fl oz, and set the Target Rate at 32 oz/acre.

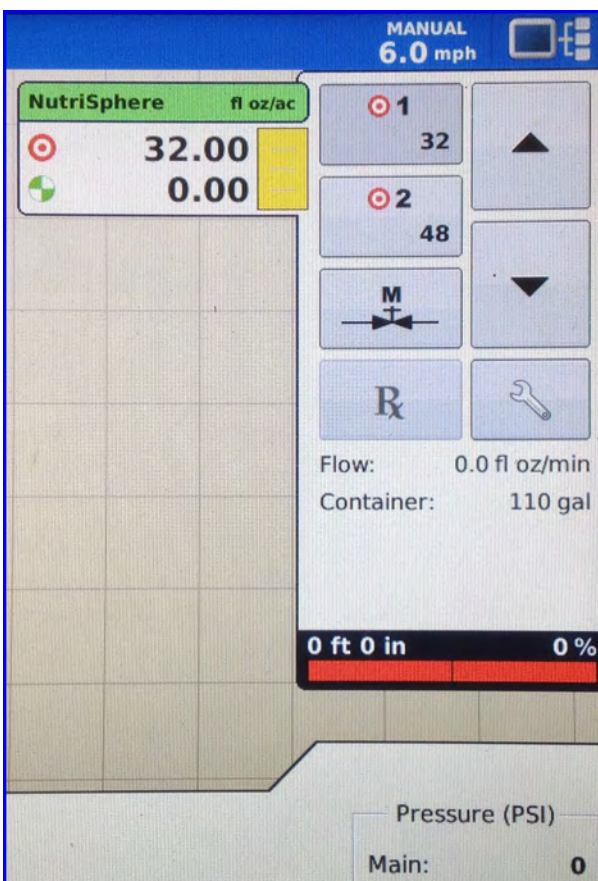

Set the **Minimum Flow** at 10 oz/min. This is the bottom rated end of the flowmeter.

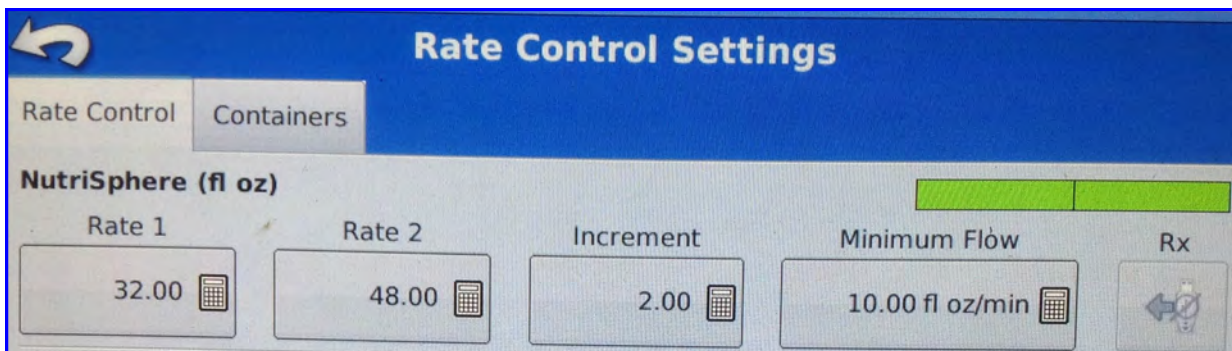

Ag Leader Display Setup (Continued)

The Grid button in the lower left corner of the screen brings up the Map screen for Run Time Operations.



The **Product Tab** is in the upper right corner of the Map screen.

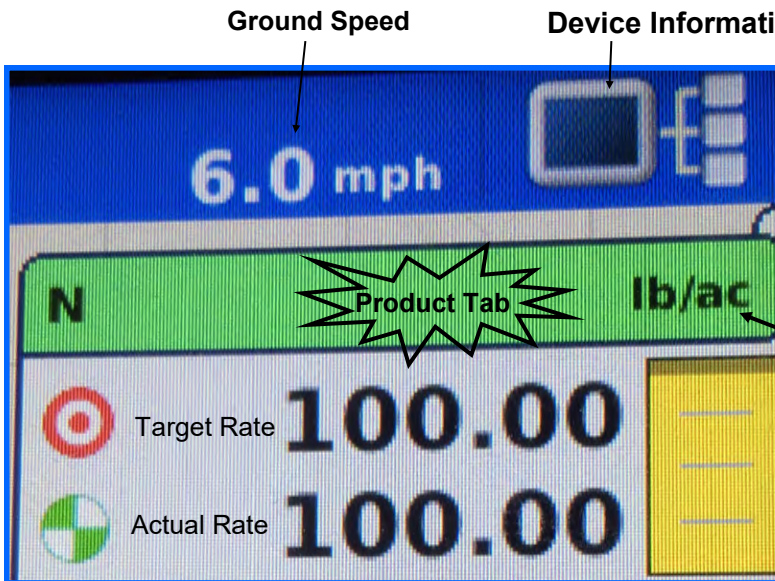

Press on the Device Information Button, then highlight the item marked **DC Liquid**, then press the **Diagnostics** button. The Liquid Diagnostics screen contains the Active Controller Name and Serial Number of the module. Also included are Main (1) and Auxiliary (2) Pressure readings, and Flowmeter Signal Frequency and Pulse Count. This can sometimes be useful troubleshooting information.

Press the **Product Tab** to bring up an extended view.

See the next page for further explanation of the items available on the Map screen.

Map Screen Product Control Toolbox

- A
- B
- C



- A
- B
- C
- D
- E
- F
- G
- H
- I
- J

- Product
- Target Rate
- Actual Rate
- Rate 1 button
- Rate 2 button
- Manual Valve Control
- Prescription button
- Rate Increase arrow
- Rate Decrease arrow
- Rate Setup button

Set Rate 1, Rate 2, and Increment here:

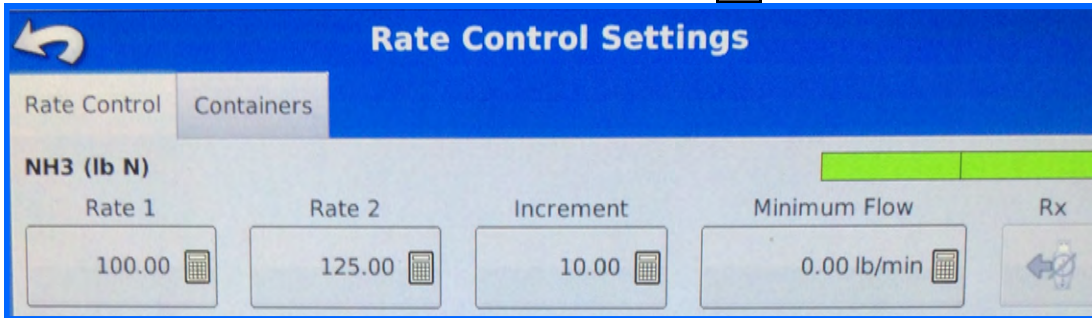

Initial Operation Instructions - Integra- Manual

SureFire highly recommends you perform these exact steps with water to verify system is correctly installed and ready for field use.

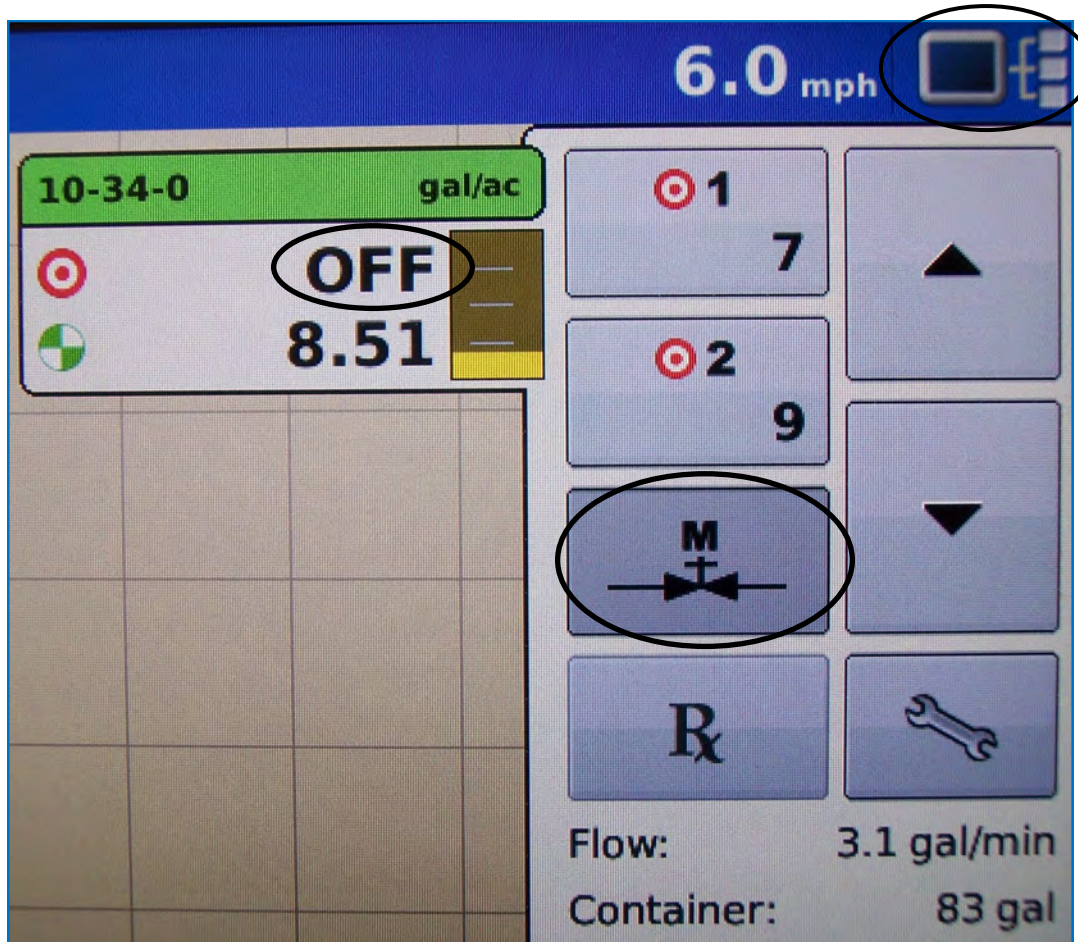

Device Information (Diagnostic) Button

1. Enter manual mode by pushing the “M” button in the upper right corner of the screen. You can tell you are in manual mode when the “Target” Rate says “OFF”.
2. If using implement lift switch, move implement switch to lowered position. If not using implement switch, jumper must be installed (see wiring diagram in section D).
3. On the Switch Box, turn the master switch On. Turn section switches On and Off to check proper section valve operation. Leave all section valves On.
4. Use up arrow on right side of screen to increase flow. Does “Flow Rate” display a flow rate? Is it stable after the system is primed? Do increase & decrease buttons increase & decrease flow?
5. When you can increase and decrease flow using the arrows, you are ready to move to the next step.
6. Conduct a catch test to verify the flowmeter calibration is correct. It is unusual if the Flow Cal number needs to be changed. (The most accurate method to measure the volume of water run is to place a container under every nozzle and add together the amount from each nozzle. This assures that 100% of the water is collected and that all rows are equal. At a minimum, collect water from 4-6 rows. **NEVER base a calibration on a single row catch.** It is important to perform this procedure at a flow rate similar to that which will be used in the field.)

Initial Operation Instructions - Integra - Auto

SureFire highly recommends you perform these exact steps with water to verify system is correctly installed and ready for field use.

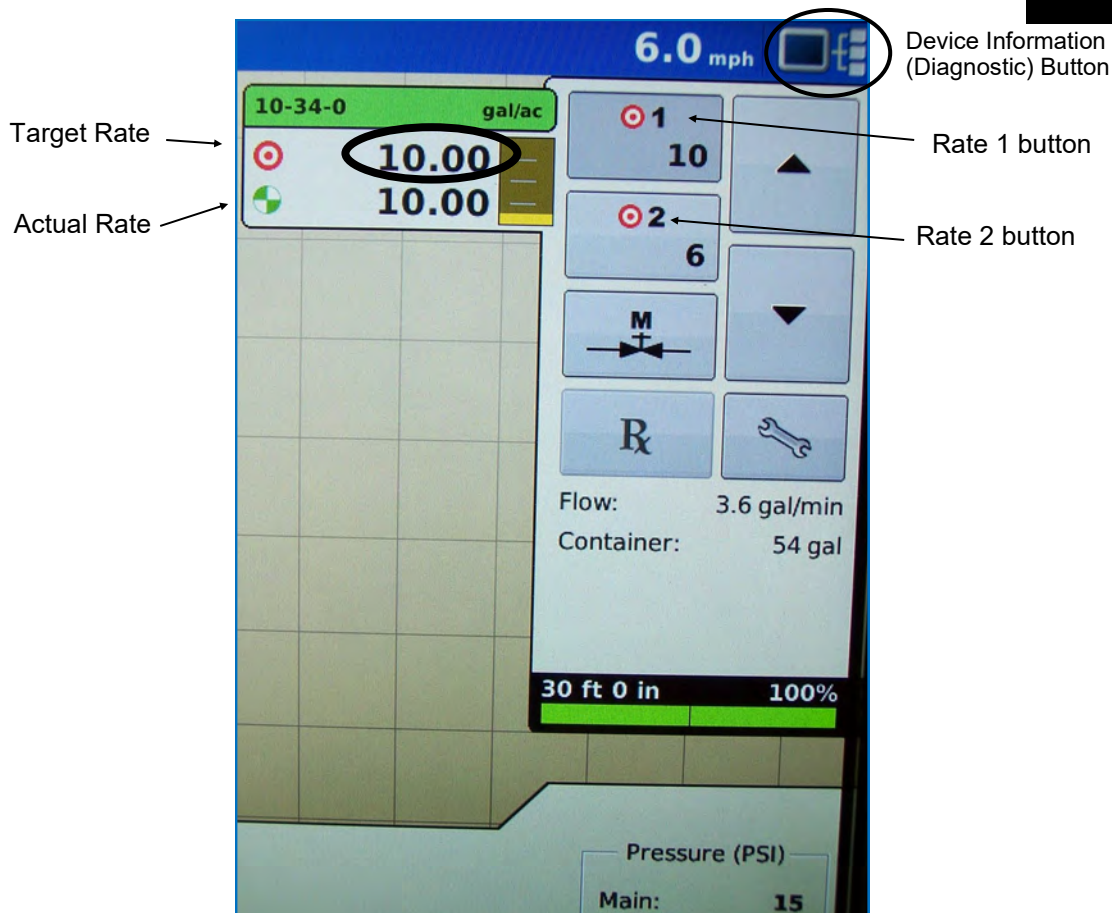

1. Push the grid button in the lower left corner to return to the main Run screen. Verify a speed in MPH is shown. If not, return to setup and enter a manual ground speed.
2. Look at the Extended Product Tab in the upper right corner. Push the “Rate 1” or “Rate 2” button to enter Auto mode. You can tell you are in Auto mode when a rate is displayed under “Target”.
3. Turn on Master and Section switches. The system should begin to pump liquid now in automatic control mode. Is the flow in GPM stable? Is it applying at the correct rate? (actual rate = target rate?)
4. Change rate using screen buttons for Rate 1 & Rate 2. Does actual rate change to equal new target rate?
5. Close 1 section valve, does flow decrease? Does applied rate still equal target rate?
6. Change speed and target rate to minimum and maximum values. Does system perform at these values? Does the system pressure seem reasonable (remember fertilizer will increase pressure over water)?

Electric Pump Won't Run

EPD Status Lights

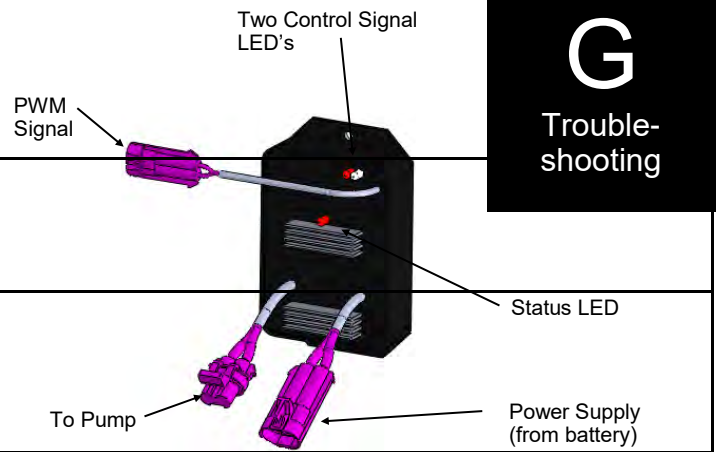

G

Trouble-shooting

Status LED	Status Description	Troubleshooting Steps
On Steady	Power input is good and PWM input Signal is detected	No Problem, Typical operating condition.
Steady Blink	Power input is good and PWM signal is not detected	Typical 'Off' Condition. If pumps should be on: 1. Inspect wiring and connectors 2. Check voltage at PWM connector to EPD, should be 1-12 volts to turn on. 3. Check voltage on PWM wires at 37 pin connector, pins 15&16.
Blink once, pause, blink once, pause	Open circuit between motor output and motor.	Check harness and connectors to motor. If using two motors, plug each in separately directly to EPD (bypassing Y-harness)
Blink twice, pause, blink twice, pause	Output short circuit detected.	<ul style="list-style-type: none"> Check motor wiring
Three blinks, pause, three blinks, pause	Overcurrent condition	<ul style="list-style-type: none"> Check total load Clean cooling fins on EPD
Four blinks, pause, four blinks, pause	Input power fault. Low voltage condition in power to EPD.	Pump operating pressure and/or flow are too high. Unplug battery power from EPD to reset. Check power cables and connections for quality. 1. Check that flow required for application rate is within pumps capability. 2. Reduce System Pressure by: <ul style="list-style-type: none"> Look for any unintended restrictions or plugged rows Increase orifice size Open up larger tube or orifice if using dual check valve. Reduce ground speed or application rate
Five blinks, pause	Input frequency out of range.	Check PWM Settings on Rate Controller.
Control Signal LEDs		
Light intensity varies	Off - No PWM Signal 100% brightness - Maximum PWM input signal	

Electric Pumps Won't Run (continued)

G

Trouble-shooting

Electric pump will not turn on

EPD flashing 4 times

1. Find the EPD (electric pump driver) shown above. Should have a steady blinking light in the middle when pumps should be off. If Status LED is flashing 4 times, then pausing, EPD has tripped due to low voltage condition. Unplug the Power Supply to the EPD to reset. If condition persists, change to larger orifices to reduce pressure, slow down, or lower application rate. Check Power Supply cables to EPD to insure solid connections and good electrical path.

No Lights on EPD

1. There should be a steady blinking light in the middle of the EPD. If no light is ON, check the 40-amp fuse in the EPD harness near the battery. Use a voltmeter to verify that there is 12-13 volts at the Power Supply connector that plugs into the EPD.

Will the pump run?

1. Connect the two large connectors that are plugged into the bottom of the EPD to each other (bypass the module and supply 12 volts directly to pump).
2. Does the pump run? If not, check the 40 amp fuse in the EPD harness near the tractor battery. Inspect harnesses and connections.

Electric pump only runs with 12 volts direct from battery

1. Connect pumps and power harness back to EPD.
2. Go to Rate Control Detail screen to investigate this issue.
3. Turn system on and push the increase button.
4. Remove PWM valve connector and check voltage. You will need 1-12 volts to turn pumps on.
5. If 1-12 volts is not present, check harnesses and review control valve type setup.
6. Go back to the Liquid Product Control Module. Check voltage between pins 2 and 7 of the eight-pin connector. The voltage should be between 6-12 volts after holding increase button in manual mode.
7. If you cannot get voltage at pins 2 and 7, contact your Ag Leader dealer for further assistance.

Section Valve(s) will not move

1. Go to Rate Control Detail to investigate this issue.
2. Turn section valve switches on switch box On and Off. Do you have a problem with one or all the valves?

Pin	Function
A	+ 12 V Constant
B	Ground
C	+ 12 V Signal

3. Check the harness connection to that valve. It is a 3-Pin Weather Pack connector. See Section D for wiring diagrams

4. Check voltage pin A to Pin B. Must be 12 volts, if not, go back to 2-pin power connector

5. If voltage is present on pins A&B of 3-pin connection to valve, then check pin C to Pin B. This should be 12 volts when the valve is commanded on or open, this should be zero volts when valve is off or closed.
6. If signal voltage is not present to open valve, use diagrams to check at the 16-pin , then the 12-pin on the Ag Leader Liquid Product Control Module for voltage on the proper pin for that section.
7. If constant voltage (Pins A&B) and switched voltage (Pins C&B) are present, inspect, repair or replace the valve.

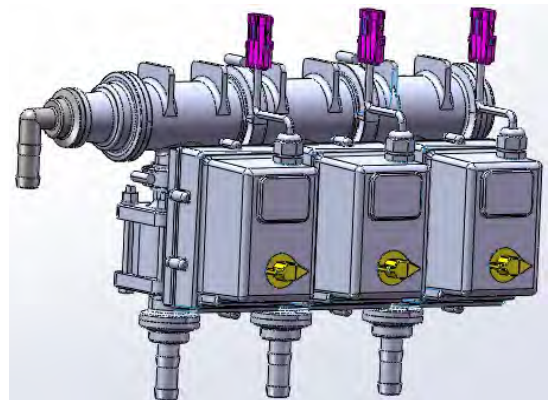

Application Rate & Flow Troubleshooting

G

Trouble-
shooting

Application Rate Fluctuates

First, you need to determine if the fluctuation is caused by the controller sending fluctuating signals to the valve.

1. **Inspect & clean pump inlet strainer.** Strange flow rate fluctuations are very often due to an obstruction to the pump inlet. Inspect plumbing from tank to pump.

OR

1. Go to Rate Control Detail Screen as shown in Initial Operation, Section F.
2. Turn the system on and watch the flow in GPM.
3. Is the flow steady within a very small range? For example a fluctuation from 2.3 to 2.5 GPM would be considered normal. A fluctuation from 2-3 GPM is a problem. If only a small normal fluctuation is seen, skip steps 4-8 and proceed to "Application Rate Fluctuates in Field " below.
4. If there is a large fluctuation, observe the system flow. Is the discharge a steady stream? Are the flow indicator balls floating steady?
5. If visually the flow is steady, but the display reports a fluctuation in GPM, inspect the flowmeter. See section B for flowmeter information.
6. If visually the flow is unsteady, the flowmeter is working correctly reporting a flow problem. Is the pump turning steady or surging?
7. Look for any type of obstruction in the pump inlet. Clean the strainer. If continually plugging the strainer, investigate fertilizer quality and necessary strainer size.

Application Rate fluctuates in field, but flow in manual mode is stable.

This problem indicates the PWM gain needs changed. The system is surging because the Liquid Product Control Module is moving the pump driver too much.

1. Go to Controller Settings.
2. Change the settings by reducing the PWM gain (start with increments of 500).

Application Rate is slow to get to the Target Rate

1. You may need to increase the valve calibration. Go to Controller Settings.
2. Change the settings by increasing the PWM gain. SureFire recommends a PWM gain of 5000 for electric pump Catalyst systems.
3. If the system is slow to get to Target Rate when starting, increase the Zero Flow Offset (see pages 37 and 38).

No Flow shown on Ag Leader display but liquid is being pumped

1. Unplug flowmeter. With voltmeter, check for 12 volts between pins B&C of flowmeter connector (on main harness PN 215223). If 12 volts not present, inspect wiring harness and troubleshoot all connections per schematic (see Section D).
2. If 12 volts is present, then conduct a tap test. Go to setup and change the flow cal to 100. Have a second person watch GPM on the Rate Control Detail screen while other person taps (use a short piece of wire or a paper clip) between pins A&C of flowmeter connector (on 215223 harness). A flow value should show up indicating the wiring is not damaged.
3. If the display responded to the tap test, your wiring to that point is good. If still not fixed, inspect adapter harness and test continuity per schematic (see Section D).
4. Replace flowmeter.



Flow Information at 32 oz/acre rate and 30" row spacing									
Pump Output (gal/min and oz/min)									
MPH	Oz/min/ row	20' GPM	20' OPM	30' GPM	30' OPM	40' GPM	40' OPM	60' GPM	60' OPM
4	.65	.04	5.2	.06	7.8	.08	10.4	.12	15.6
5	.81	.05	6.5	.08	9.7	.10	13	.15	19.4
6	.97	.06	7.8	.09	11.6	.12	15.5	.18	23.2
7	1.13	.07	9.0	.11	13.6	.14	18.1	.21	27.2
8	1.29	.08	10.3	.12	15.5	.16	20.6	.24	31.0
9	1.45	.09	11.6	.14	17.4	.18	23.2	.27	34.8
10	1.62	.10	13.0	.15	19.4	.20	25.9	.30	38.8
		Below flowmeter rated range							



Recommended Care and Maintenance

H

Maintenance
& Parts

Winterization

SureFire recommends flushing your product pump and complete system with adequate amounts of water first. Next, use RV antifreeze to winterize your system by pumping an adequate amount through all components. At the beginning of the next season, begin with water to verify the system is in working order with no leaks.

Inspect Electric Pumps

The electric pump and motor is a completely sealed component. Over time the electric motor will lose efficiency. The entire pump and motor will need replaced when it won't efficiently produce the flow required.

Pre-season Service

1. Fill system with water and run in Manual mode to verify components and system are in working order.
2. Tighten all clamps. Loose clamps may be evident by leaks on the output side of the system. Loose clamps from the tank to the pump are not always apparent, but can be sources of air getting into the system which can create issues.
3. Remove the black cap from the top of each check valve. Check the diaphragm to be sure it is intact and not gummed up with residue. Look under the diaphragm for debris. Compress the spring in the cap to be sure it moves freely. Carefully replace diaphragm and tighten cap.
4. Be sure all rows are flowing and that all metering tubes are open. (Note: It will take a higher flow rate with water to create enough pressure to open all the check valves.)
5. Run the system in Auto Mode with a manual speed to verify that system will lock on to a Target Rate.



Torpedo™ NH3 Precision Anhydrous Ammonia Application

SureFire's Torpedo™ NH3 Systems are a "one-stop-shop" for all components needed to get Anhydrous Ammonia from the tank to the soil. SureFire will work with you to ensure all necessary components are supplied as part of the complete kit.

SureFire Ag Systems

9904 Hwy 25

Atwood, KS 67730

www.surefireag.com

©2015-2016 SureFire Ag Systems

