

396-001260

## Ag Leader



**Liquid Product  
Control Module**

-

**Liquid ISO Module**

-

**L2 Rate Controller**

**with PWM Control for  
Tower Electric Pump System**

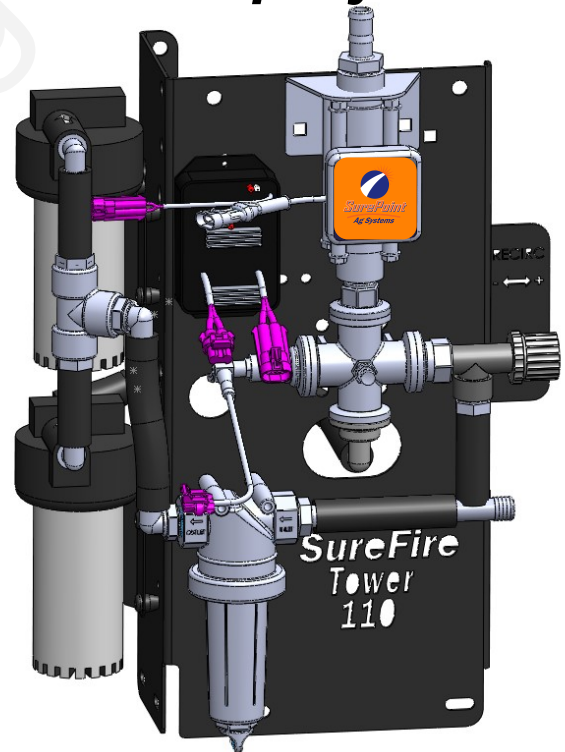
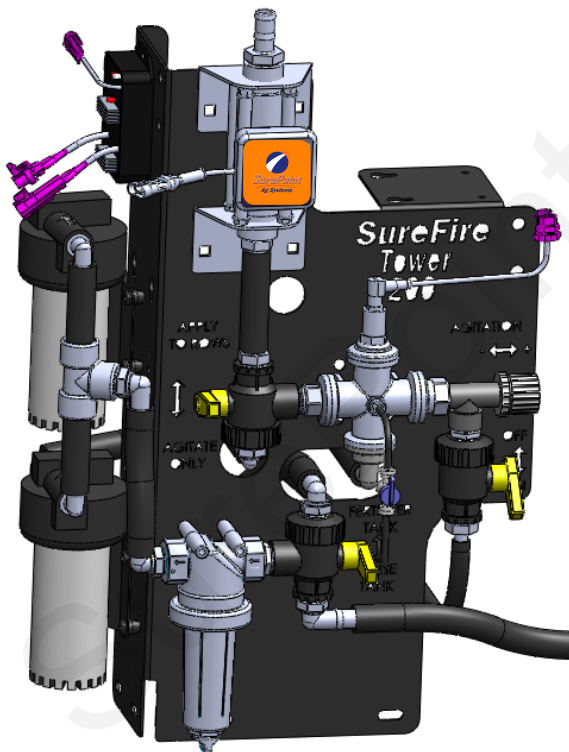

### Maximum Application Rates with Two 5.3 GPM Electric Pumps

Maximum Application Rates in GPA on 30" Rows at 6 MPH (no agitation)				
Rows	8	12	16	24
Max GPA	20	12	9	5

SurePoint Ag Systems



# Table Of Contents

## Introduction

- Safety Information, Basic Steps to Install your Fertilizer System .....2-3
- Complete Fertilizer System Example Drawings.....4-5

## Components - Liquid

- Flowmeters, Section Valves .....6-7
- Pressure Sensor, Pump Priming and Air Bleed Valve .....8
- Flow Indicators and Manifolds, Check Valves, Orifice Charts.....9-16
- Dual Check Valve Systems, Row Distribution, Metering Tube Chart .....17-21

## Components - Wiring & Electrical

- Ag Leader Liquid Product Control Module, Aux Input Module .....22-25
- ISO Liquid Rate and Liquid Swath Control Modules, L2 Rate & Swath Module 26-27
- ISO and L2 Aux Input and Imp Switch Modules, Gen 2 to Gen 1 Adapter .....28-29
- System Schematics.....30
- PWM EPD.....31
- Wiring Harness Drawings.....32-37

## Installation Overview

- Floating Ball Flow Indicators, Tower Mounting Options .....38-40
- Tower 110 Plumbing Overview and Valve Operation, Recirculation .....41
- Tower 200 Plumbing Overview and Valve Operation, Agitation.....42-43

## Setup & Operation (See this for initial setup and startup)

- Display Setup for LPCM, Configuration Setup, Liquid App Channel Setup .....44-45
- Controller Setup, Control Valve Settings, Manual Speed Entry .....46-47
- Pressure Sensor, Swath Control, Aux Input, Equipment Settings.....48
- Configuration Setup, Product Setup, Equipment Setup .....49
- Run Screen, Auto Test, Liquid diagnostics, Manual Test.....50-52
- InCommand / ISO Liquid Setup.....53
- Speed Input, Automatic Swath Control, Equipment Configuration .....54
- Product Setup .....55
- Equipment Setup—Vehicle, Implement, Controller.....56
- Controller Settings, Control Valve Settings, ISO Settings, Universal Terminal..57
- UT and Liquid ISO Run Screen, Settings, Calibration .....58-62
- Ag Leader Run Screen for ISO Liquid .....63-64

## Troubleshooting

- Pump Will Not Run, EPD Status Lights, Section Valve Won't Move .....65-67
- Application Rate Fluctuates, Slow Getting to Target Rate.....68
- Flowmeter Tap Test, Liquid Diagnostics Screen.....69-70

## Maintenance & Parts

- Winterization.....71
- Pre-season Service .....72-73

A

Introduction

B

Components  
Liquid

D

Components  
Wiring & Elec.

E

Installation  
Overview

F

Setup &  
Operation

G

Trouble-  
Shooting

H

Maintenance  
& Parts





# Safety

**TAKE NOTE! THIS SAFETY ALERT SYMBOL FOUND THROUGHOUT THIS MANUAL IS USED TO CALL YOUR ATTENTION TO INSTRUCTIONS INVOLVING YOUR PERSONAL SAFETY AND THE SAFETY OF OTHERS. FAILURE TO FOLLOW THESE INSTRUCTIONS CAN RESULT IN INJURY OR DEATH.**



**THIS SYMBOL MEANS  
ATTENTION!**

**BECOME ALERT!**

**YOUR SAFETY IS INVOLVED!**

Note the use of the signal words DANGER, WARNING and CAUTION with the safety messages. The appropriate signal word for each has been selected using the following guidelines:



**DANGER:** Indicates an imminently hazardous situation that, if not avoided, will result in death or serious injury. This signal word is to be limited to the most extreme situations typically for machine components which, for functional purposes, cannot be guarded.



**WARNING:** Indicates a potentially hazardous situation that, if not avoided, could result in death or serious injury, and includes hazards that are exposed when guards are removed. It may also be used to alert against unsafe practices.



**CAUTION:** Indicates a potentially hazardous situation that, if not avoided, may result in minor or moderate injury. It may also be used to alert against unsafe practices.

**NOTICE** is used to address safety practices not related to personal safety.



## A Word to the Operator

SAFETY IS YOUR RESPONSIBILITY.

YOU are the key to safety.

It is YOUR responsibility to read and understand the safety messages in this manual.

This system may be used to apply many different kinds of agricultural liquid products. Read and follow all label information and instructions related to the handling, storage, and application of the product you are using.

All electrical harnessing should be checked regularly and should be routed and secured so it will not be pinched, cut, or stretched.

# General Description

## A

### Introduction

You have purchased a SurePoint fertilizer system for your equipment. This system will be controlled by your Ag Leader display and Ag Leader Liquid Product Control Module or ISO Liquid Module, which you will need to purchase from your Ag Leader dealer. The rate controller will adjust the speed of the SurePoint electric pumps based on feedback from the flowmeter and vehicle speed. The system is capable of section control to minimize overlap areas with optional section valves. The system will also use the Ag Leader Aux Input Module and DirectCommand.

## Basic Installation Steps

1. Install Ag Leader display, Liquid Product Control Module, Aux Input Module, and DirectCommand per Ag Leader instructions.
2. Open the packages and familiarize yourself with the components. Refer to manual sections B & D for component information.
3. Mount the Tower on your equipment.
4. Plumb the tank to the Tower inlet. See section E for details.
5. Install the plumbing kit including section valves, flow indicator columns / manifolds, check valves, plumbing to each row unit delivery point. See section B for information on these components.
6. Attach the flowmeter outlet to section valve or manifold inlet. Attach section valve outlets to flow indicator inlets.
7. Attach harnesses as shown in Section D. Be sure to plug in the 2-pin Deutsch power connector.
8. Set up Controller for SurePoint fertilizer system as shown in Section F. For Ag Leader **L2 Rate Controller**, see the latest [Ag Leader documentation :Part No 2006954 - Direct Command L2 Rate Controller Manual](#). Many of the screenshots in Section F of this manual for the Ag Leader Liquid ISO Module are similar to the L2 screenshots.
9. Fill system with water, conduct initial operation and tests per Section F.
10. Winterize system with RV Antifreeze if freezing temperatures are expected.
11. Do pre-season service checks every year.

# System Overview - Example 1

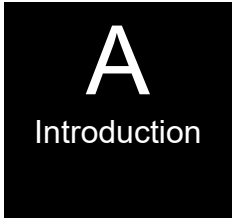

The following gives an example of a complete SurePoint Fertilizer system with these components:

- Ag Leader Display
- Ag Leader Liquid Product Control Module, Aux Input Module, and DirectCommand
- Tower 110
- Section Valves
- Flow Indicators
- Check Valves with Colored Disc Orifices

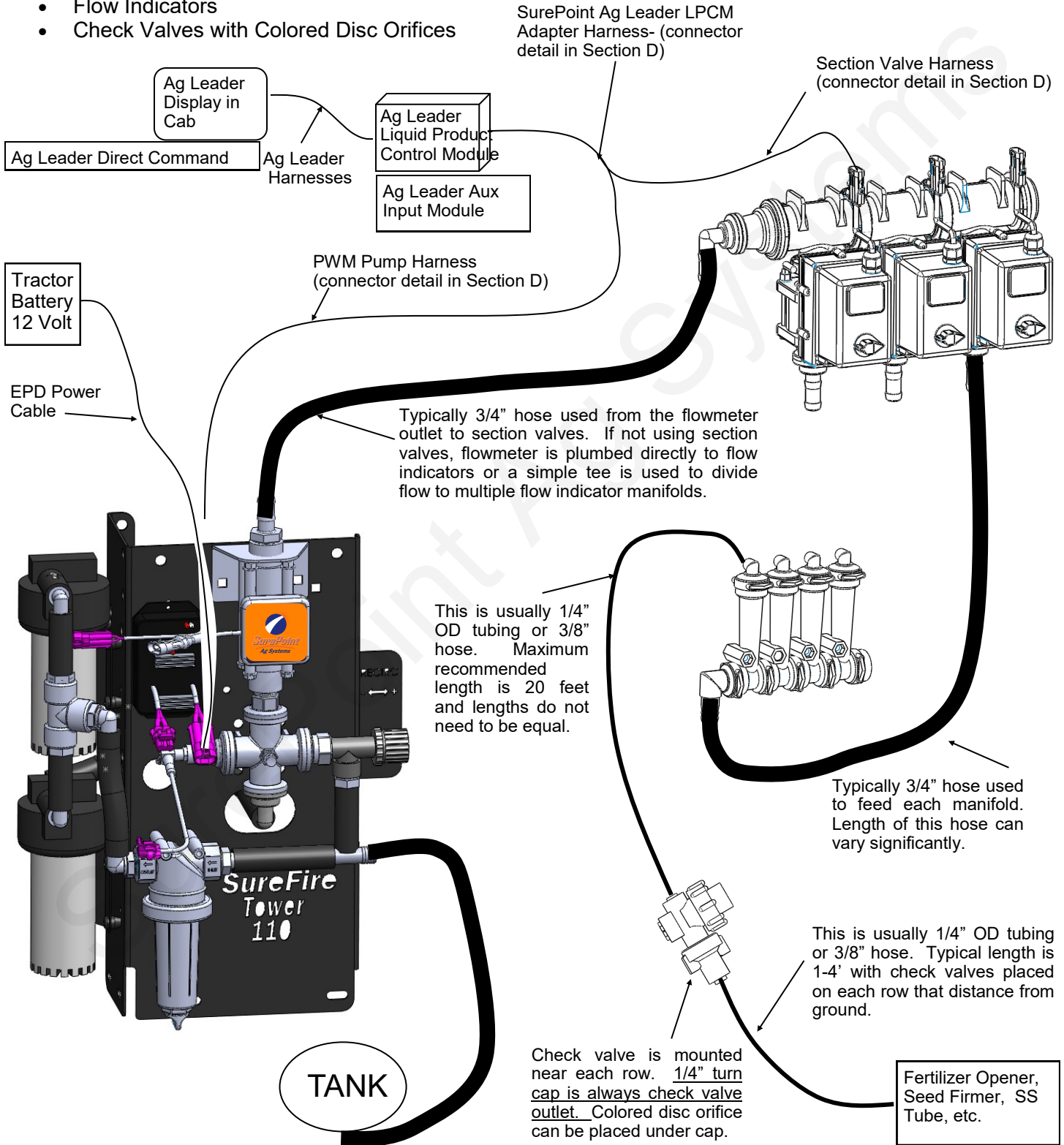

# System Overview - Example 2

The following gives an example of a complete SurePoint Fertilizer system with these components:

- Ag Leader Display
- Ag Leader Liquid Product Control Module, Aux Input Module, and DirectCommand
- Accelerator with Tower 200
- Dual Check Valve Distribution System
- Dual Metering Tube

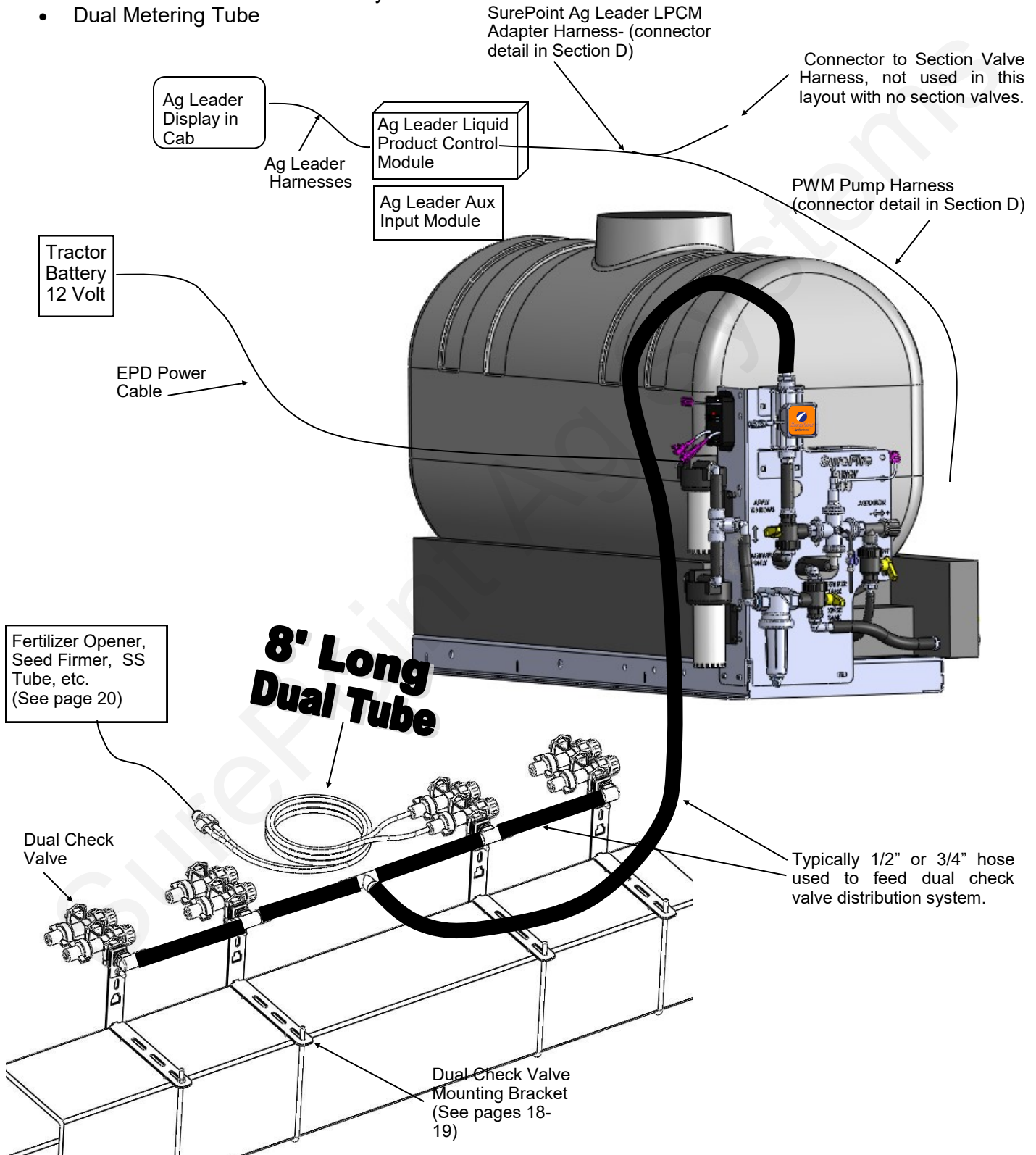

# Electromagnetic Flowmeter Kits

0.13 - 2.6 GPM  
 0.3 - 5.0 GPM  
 0.08 - 1.6 GPM

Item Number 500-02-2040  
 Item Number 500-02-2050

Flowmeter Only  
 204-01-46211CUF00  
 204-01-46211CUF01  
 204-01-46211CUF05

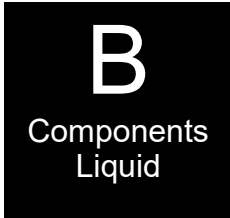

Kits include flowmeter, mounting bracket, hose barb fittings & hose clamps.

**Before doing any arc welding on the implement, unplug the cable to the flowmeter, or damage to the flowmeter may result.**

**New Look in 2017—Black body with orange label. Same accurate, reliable electromagnetic technology. 3-pin Amp SuperSeal connector is sealed to flowmeter body for tighter, cleaner connection.**

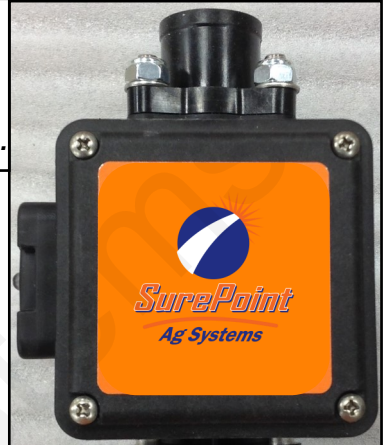

Mounting Bracket, Used in Tower 110 & 200 (Tower 200 shown) 410-2106Y1

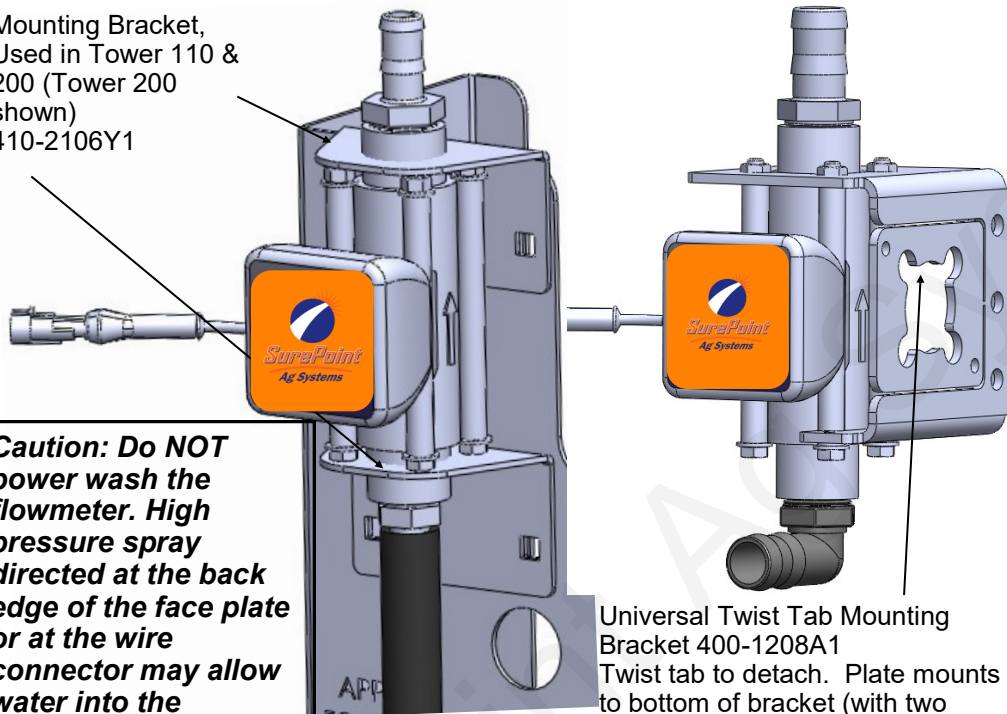

**Caution: Do NOT power wash the flowmeter. High pressure spray directed at the back edge of the face plate or at the wire connector may allow water into the flowmeter electronics.**

Universal Twist Tab Mounting Bracket 400-1208A1  
 Twist tab to detach. Plate mounts to bottom of bracket (with two 1/4"x1" carriage bolts) to capture flowmeter.

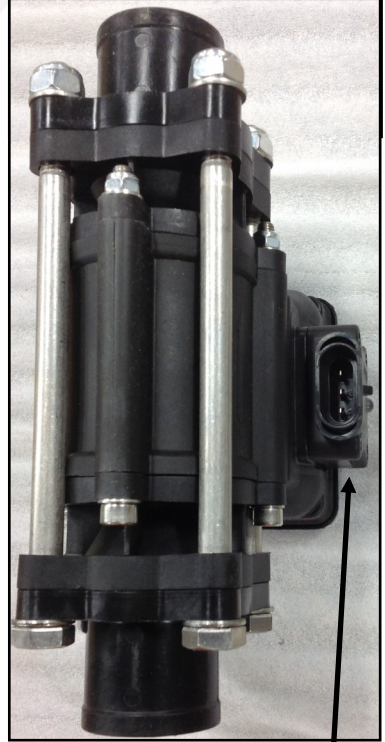

Amp SuperSeal 3-pin connector Use adapter 201-17842 to connect to 3-pin MP harness

Electromagnetic flowmeters are superior to traditional turbine flowmeters in two basic ways. First, they have no moving parts. This translates into no wear items or potential for contaminants to jam a spinning turbine.

Second, electromagnetic flowmeters detect the flow by electrically measuring the velocity of the liquid, which makes them less sensitive to viscosity or density of the fluid measured. They are generally extremely accurate using the standard calibration number.

**SurePoint still recommends you perform a catch test to verify the system is properly installed and configured. Adjust the flow cal as needed based on accurate catch tests with the actual product or observation of gallons applied and acres worked.**

Flowmeter Model (orange label or blue label)	Pulses/Gal	FPT Size	Hose Barb In kit	Flowmeter Low Limit
0.13 - 2.6 GPM	3000	3/4"	3/4"	0.1
0.3 - 5.0 GPM	3000	3/4"	3/4"	0.2
0.08-1.6 GPM	22710	3/4"	3/4"	-



Serial number label on side also shows pulses per gallon.

**\* Earlier model flowmeters (meters with white labels with black text) have different calibration numbers. See the documentation for those meters or look on serial number sticker to find calibration numbers.)**



# Section Valves

**B**  
Components  
Liquid

105-100075BRB90

105-100PLG (alternate  
105-100PLG025 includes 1/4" pipe  
thread for gauge)

Note: Ensure back-side port  
is capped prior to use

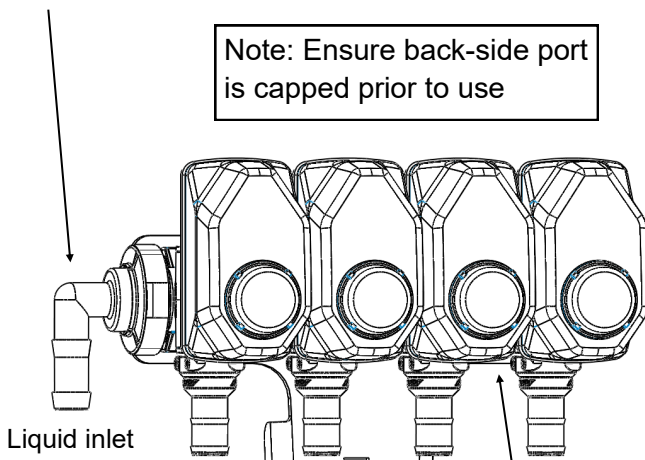

117-211-0066  
Liquid outlet to each section

103-2501Y1 (single complete valve)  
KZ Electric TX2 Series, 1 ball valve

**Additional Parts:**

- 1" Gasket 105-100G-H
- 1" Clamp 105-FC100

**Tower 110 Section Valve  
Bracket  
Item Number 410-2110Y2**

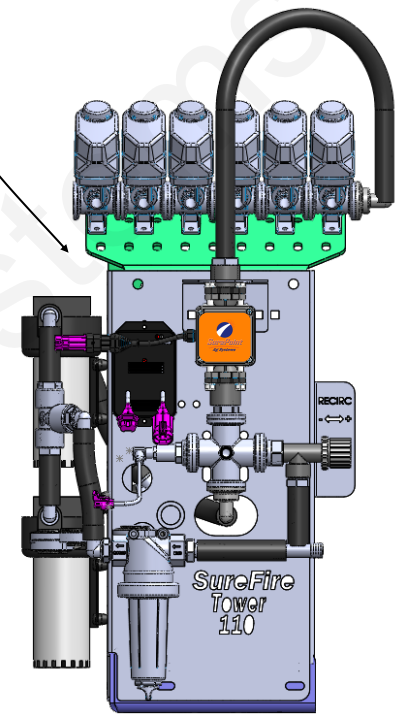

The Tower 110 can have up to 6 section valves mounted directly to the top of it with this bracket.

Green Light-  
Valve ON

Red Light  
Valve OFF—  
connected to  
Power

Replacement Valve Actuator—  
104-KZ1169—KZ Electric TX2  
Series Actuator

If valve indicator stays GREEN all the time or if valve indicator is not in full ON or full OFF position, replace actuator. Pull gray pin to remove actuator from valve.

**This is a 3-way valve.** If product will not flow when valve is ON, either move the outlet hose to the other port, or remove actuator and rotate valve ball 180°, and replace actuator.

**How it Works**

Section valves can be assembled into groups with a common inlet to control flow to each section. Common assemblies use up to 5-6 valves, however, more can be used where practical. Many alternate fittings can be used to accommodate different hose sizes and configurations.

The valves have a 3-pin weather pack electrical connector. This has a power, ground, and switched signal wire. The power measured to ground should have 12 volts when the controller is on. The switched signal wire will have 12 volts to turn the valve on, and 0 volts to turn the valve off.

**Wiring Connector:**  
Pin A—Red, 12 Volts +  
Pin B—Black, Ground -  
Pin C—White, Signal  
12V=on ; 0V=off

**Mounting Hardware:**  
2 Valve Bolt Kit 384-1100  
Mounting Bracket 400-2493Y1



# Pressure Sensor

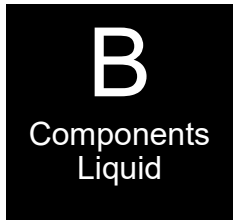

The Tower 110 and 200 come equipped with a 100 psi (0 to 5 volt) pressure sensor to work with Ag Leader. This sensor is a 3 wire type sensor for compatibility with Ag Leader. The sensor has a 1/4" MPT fitting. The Ag Leader display has the ability to show pressure from 2 sensors on the display.

The Ag Leader display will show the system pressure on the in cab screen. The pressure reading is only for informational purposes and is NOT used in the flow control process. Flow control uses the flowmeter feedback only.

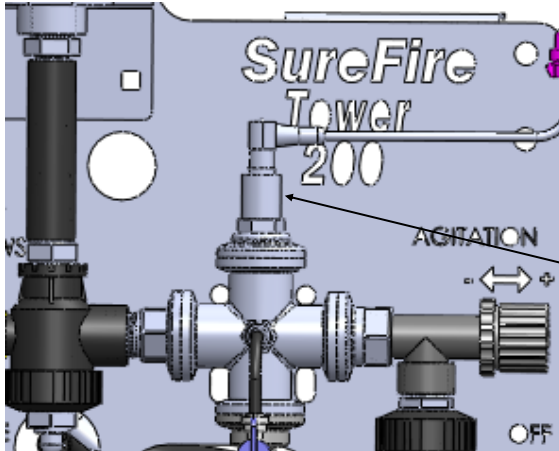

The pressure sensor is very helpful to optimize system performance and troubleshoot any issues.

The pressure transducer is factory calibrated and will display a very accurate pressure reading on the Ag Leader display. No manual gauge is required.

Pressure Sensor (3-wire type) with harness  
521-05-050150

Ag Leader Pressure Calibration:  
50 mv/psi

# Pump Priming and Air Bleed Valve

An air bleed valve is included with each pump to aid in system priming. It is shipped in the pump accessories bag and must be installed during system installation.

## Why use an air bleed valve:

Most fertilizer systems are equipped with a 4 lb or 10 lb check valve on the end of each hose delivering fertilizer to the ground. These valves do not let air escape from the system, unless it is pressurized. 12-volt liquid pumps are not good air compressors. Therefore, the pump can struggle to prime due to air trapped on the outlet side of the pump.

The air bleed valve is a small 1/4" valve that when opened lets air escape from the pump outlet at zero pressure. Open until liquid comes out and then close the valve.

## How to install the air bleed valve:

Remove the 1/4" plug from the quick connect fitting on the center cross on the Tower (see picture). Next, insert the 1/4" tubing in the quick connect fitting. Run the 1/4" tubing to an easily accessible spot on your equipment. Next, cut the tubing and push the 1/4" valve onto the tubing. Finally, run the tubing to a low location where any fertilizer that escapes will run on the ground.

**Be sure the air bleed valve tube does not become plugged with dirt or it will not allow the air to bleed.**

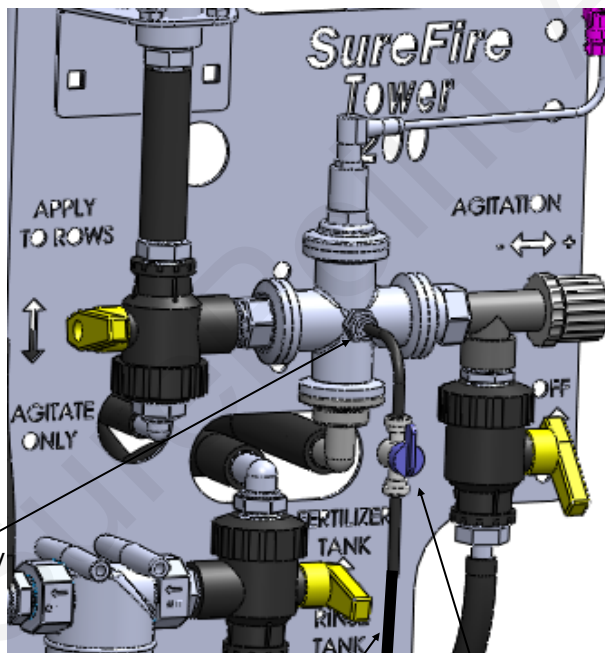

Shipped from factory with plug installed.

1/4" Tubing

1/4" air bleed valve

# Product Distribution

**To assure proper and even distribution to each row, the product being applied must be metered to each individual row. This metering is done by one of the 3 following methods which create back pressure so an equal amount of liquid is applied to each row.**

1. A metering orifice may be placed in the top cap of each floating ball flow indicator. (See photos on page 11—this is not used very often)
2. A metering orifice may be placed in the check valve cap in the line that leads to each row. (See photo on page 13)
3. A dual metering tube kit with dual check valves may be used. (See pages 17-21)

**B**  
Components  
Liquid

## Floating Ball Flow Indicator & Manifold System

Flow indicators give a clear visual signal that a fertilizer system is working. These indicators use an o-ring and wire clip connection to snap together in any configuration necessary.

SurePoint has simple tee brackets and U-bolts that will mount these to a variety of bar sizes.

Two main types of flow indicators are used. On 30" row spacing, the low flow column with 1/4" push to connect outlet is recommended for rates under 10 GPA. For rates over 10 GPA the full flow column with 3/8" hose barb outlet is preferred.

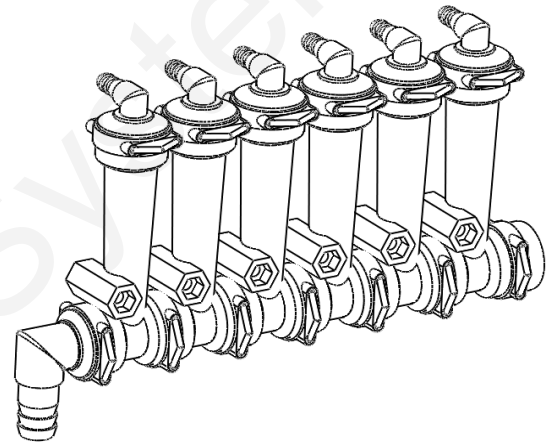

### Parts List

#### Complete Columns

701-20460-950	Single Full Flow Column with 3/8" HB - 90 Degree Outlet
701-20460-940	Single Full Flow Column with 3/8" QC - 90 Degree Outlet
701-20460-960	Single Full Flow Column with 1/2" HB - 90 Degree Outlet
701-20460-935	Single Low Flow Column with 3/8" QC - 90 Degree Outlet
701-20460-920	Single Low Flow Column with 1/4" QC - 90 Degree Outlet

#### Fittings

701-20503-00	ORS x 3/4" HB - Straight
701-20511-00	ORS x 3/8" HB - 90 Degree
701-20512-00	ORS x 1/2" HB - 90 Degree
701-20513-00	ORS x 3/4" HB - 90 Degree
701-20516-00	ORS x 1/4" QC - 90 Degree
701-20517-00	ORS x 3/8" QC - 90 Degree
701-20518-00	ORS x 1/4" FPT - 90 Degree
701-20519-00	ORS x 1/4" FPT - Straight
701-20520-00	ORS Male x ORS Female - 90 degree
701-20521-00	Wilger End Cap
701-20523-00	ORS Male x ORS Female x 3/8" FPT - Isolator
701-20525-00	ORS Male x ORS Male x 1" FPT - Tee

#### Service Parts Only

701-20460-02	Wilger Flow Indicator Ball Retainer
701-20460-03	FKM O-Ring for indicator body & fittings
701-20460-04	Wilger Lock U-clip
701-20460-05	Flow Indicator Ball - 1/2" SS Ball
701-20460-06	Flow Indicator Ball - Maroon Glass
701-20460-07	Flow Indicator Ball - Red Celcon
701-20460-08	Flow Indicator Ball - Green Poly
701-20460-09	Flow Indicator Ball - Black Poly
701-20460-15	Viton O-Ring for column & fittings
701-40225-05	Viton O-Ring for Orifice

#### Brackets & U-Bolts

400-1037A1	3-6 Row Bracket
400-3155Y1	7-12 Row Bracket
400-2011A1	White Backer Plate for 3-6 Row Bracket
400-2010A1	White Backer Plate for 7-12 Row Bracket
400-1315A2	Flow Indicator Bracket, 6-8 in wide hitch mount

## Floating Ball Flow Indicators- Full Flow Column (mostly 3/8" HB)

The full flow column is typically used with rates over 10 GPA on 30" rows. For rates less than 10 GPA SurePoint recommends the low flow columns with 1/4" push to connect outlet fittings.

The full flow columns are most often assembled with 3/8" hose barb outlets. See the low flow info below for the difference between full and low flow columns.

### Full Flow Indicators w/ 3/8" Hose Barb Outlet

Column Flow (GPM): .05-2.70 GPM  
Equivalent Application Rate  
On 30" Rows at 6 MPH: 2-70 GPA

### Ball Selection for 30" Rows

GPM	GPA	Ball
.05-.18	2-6 *	Green Plastic*
.09-.30	3-10 *	Red Plastic*
.31-.72	10-20	Maroon Glass
.40-2.1	13-70	Stainless Steel (1/2")

\*SurePoint recommends using the low flow column for these flow rates.

Plastic balls may float on heavier fertilizers, such as 10-34-0.

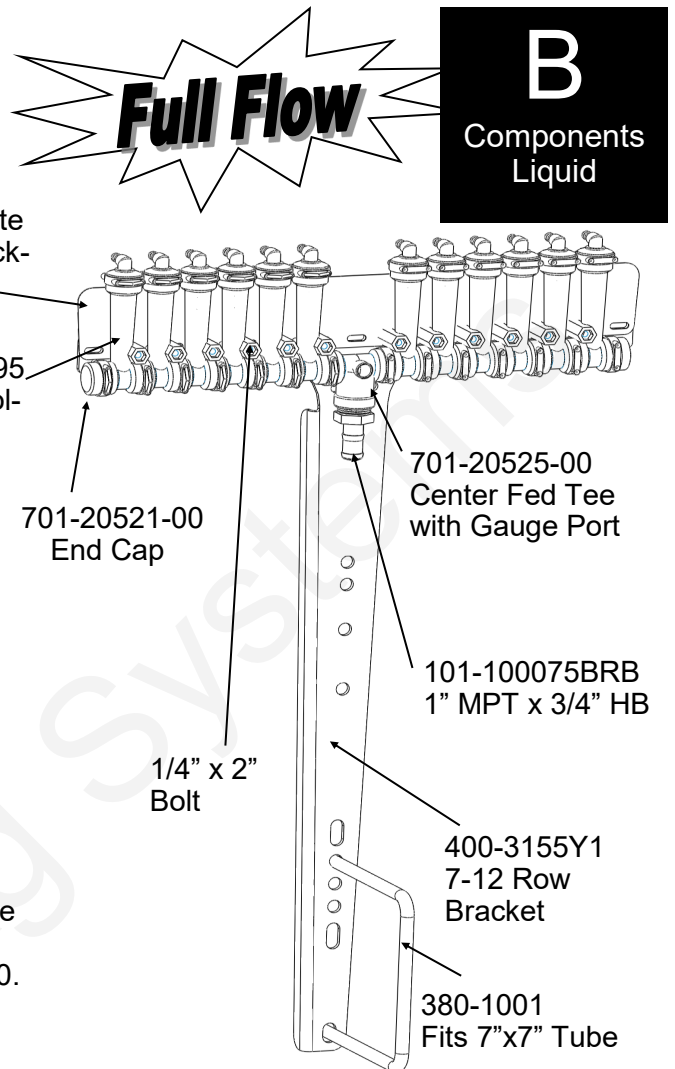

## Low Flow Column (mostly 1/4" QC)

The low flow column has a smaller internal diameter. This means a heavier ball can be used to monitor a smaller flow.

SurePoint uses the low flow columns with 1/4" push to connect outlet fittings. The flow capability of 1/4" tubing and the low flow column are a great pair for rates on 30" rows under 10 GPA.

Externally, the low flow column can only be identified by "Low Flow" molded into one side of the column. All the same fittings work with low flow and full flow columns.

### Low Flow Indicators w/ 1/4" Push to Connect Outlet

Column Flow (GPM): .03-.30 GPM  
\*\*\* Low Flow Column with 3/8" hose barb .03 - .70 GPM  
Equivalent Application Rate  
On 30" Rows at 6 MPH (1/4" QC): 1-10 GPA

### Ball Selection for 30" Rows

GPM	GPA	Ball
.03-.09	1-3	Green Plastic*
.05-.14	2-4	Red Plastic*
.10-.18	3-6	Maroon Glass
.15-.70	5-10	Stainless Steel (1/2")

\*These balls may float on heavier fertilizers, such as 10-34-0. Use Maroon Glass in this case.

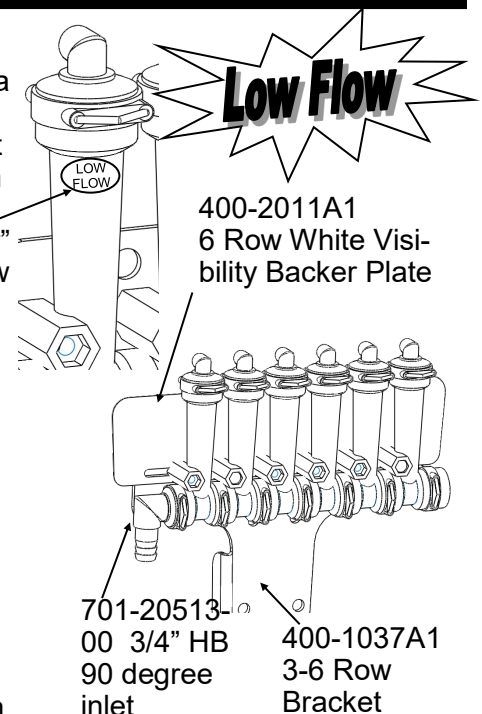

# Floating Ball Flow Indicators– Metering Orifice Selection for 30” Rows

See [www.SurePointag.com](http://www.SurePointag.com) for other row spacings

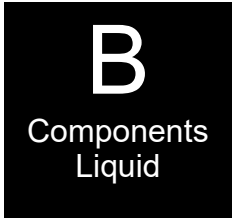

## 30” Spacing

Orifice	PSI	Gal/Min 28-0-0	MPH						
			4.0	4.5	5.0	5.5	6.0	6.5	7.0
28	10	0.043	2.15	1.91	1.72	1.56	1.43	1.32	1.23
	20	0.061	3.02	2.69	2.42	2.20	2.02	1.86	1.73
	30	0.075	3.72	3.31	2.98	2.71	2.48	2.29	2.13
	40	0.087	4.29	3.82	3.43	3.12	2.86	2.64	2.45
	50	0.097	4.82	4.28	3.85	3.50	3.21	2.97	2.75
	60	0.106	5.26	4.67	4.21	3.82	3.50	3.23	3.00
35	10	0.070	3.46	3.08	2.77	2.52	2.31	2.13	1.98
	20	0.098	4.86	4.32	3.89	3.54	3.24	2.99	2.78
	30	0.120	5.96	5.30	4.77	4.33	3.97	3.67	3.40
	40	0.139	6.88	6.11	5.50	5.00	4.58	4.23	3.93
	50	0.156	7.71	6.85	6.17	5.61	5.14	4.74	4.41
	60	0.170	8.41	7.48	6.73	6.12	5.61	5.18	4.81
40	10	0.090	4.47	3.97	3.57	3.25	2.98	2.75	2.55
	20	0.127	6.31	5.61	5.05	4.59	4.21	3.88	3.60
	30	0.157	7.75	6.89	6.20	5.64	5.17	4.77	4.43
	40	0.181	8.94	7.94	7.15	6.50	5.96	5.50	5.11
	50	0.202	9.99	8.88	7.99	7.26	6.66	6.15	5.71
	60	0.221	10.95	9.73	8.76	7.96	7.30	6.74	6.26
46	10	0.119	5.91	5.26	4.73	4.30	3.94	3.64	3.38
	20	0.169	8.37	7.44	6.69	6.08	5.58	5.15	4.78
	30	0.207	10.25	9.11	8.20	7.45	6.83	6.31	5.86
	40	0.239	11.83	10.51	9.46	8.60	7.88	7.28	6.76
	50	0.267	13.23	11.76	10.58	9.62	8.82	8.14	7.56
	60	0.293	14.50	12.89	11.60	10.55	9.67	8.92	8.29
52	10	0.149	7.36	6.54	5.89	5.35	4.91	4.53	4.21
	20	0.210	10.38	9.23	8.31	7.55	6.92	6.39	5.93
	30	0.257	12.70	11.29	10.16	9.24	8.47	7.82	7.26
	40	0.296	14.67	13.04	11.74	10.67	9.78	9.03	8.39
	50	0.332	16.43	14.60	13.14	11.95	10.95	10.11	9.39
	60	0.363	17.96	15.96	14.37	13.06	11.97	11.05	10.26
63	10	0.218	10.78	9.58	8.62	7.84	7.18	6.63	6.16
	20	0.307	15.20	13.51	12.16	11.05	10.13	9.35	8.69
	30	0.376	18.62	16.55	14.89	13.54	12.41	11.46	10.64
	40	0.435	21.51	19.12	17.21	15.64	14.34	13.24	12.29
	50	0.486	24.05	21.38	19.24	17.49	16.03	14.80	13.74
	60	0.532	26.33	23.40	21.06	19.15	17.55	16.20	15.04
78	10	0.341	16.87	14.99	13.49	12.27	11.24	10.38	9.64
	20	0.481	23.83	21.18	19.06	17.33	15.89	14.66	13.62
	30	0.590	29.22	25.97	23.37	21.25	19.48	17.98	16.70
	40	0.681	33.73	29.98	26.98	24.53	22.49	20.76	19.27
	50	0.762	37.72	33.53	30.17	27.43	25.14	23.21	21.55
	60	0.835	41.31	36.72	33.05	30.04	27.54	25.42	23.60
98	10	0.553	27.38	24.34	21.90	19.91	18.25	16.85	15.64
	20	0.782	38.72	34.42	30.98	28.16	25.82	23.83	22.13
	30	0.956	47.31	42.05	37.85	34.41	31.54	29.11	27.03
	40	1.106	54.76	48.67	43.81	39.82	36.50	33.70	31.29
	50	1.239	61.33	54.51	49.06	44.60	40.88	37.74	35.04
	60	1.354	67.02	59.58	53.62	48.74	44.68	41.24	38.30
107	10	0.649	32.11	28.54	25.69	23.35	21.41	19.76	18.35
	20	0.920	45.56	40.50	36.45	33.13	30.37	28.04	26.03
	30	1.124	55.63	49.45	44.51	40.46	37.09	34.24	31.79
	40	1.301	64.39	57.24	51.52	46.83	42.93	39.63	36.80
	50	1.451	71.84	63.86	57.47	52.25	47.89	44.21	41.05
	60	1.584	78.41	69.70	62.73	57.03	52.27	48.25	44.81
130	10	0.938	46.43	41.27	37.15	33.77	30.96	28.57	26.53
	20	1.319	65.27	58.02	52.22	47.47	43.51	40.17	37.30
	30	1.619	80.16	71.26	64.13	58.30	53.44	49.33	45.81
	40	1.867	92.43	82.16	73.94	67.22	61.62	56.88	52.82
	50	2.088	103.38	91.89	82.70	75.19	68.92	63.62	59.07
	60	2.292	113.46	100.85	90.76	82.51	75.64	69.82	64.83

### Tower Electric Pump Pressure Recommendations (with 4 lb check valves):

- Minimum 10 PSI
- Maximum 30 PSI *(The pumps will operate up to 60 PSI, but the pump output decreases greatly at higher pressures. If pump will hit rate, high pressure is not a problem.)*

### PumpRight Pressure Recommendations (with 10 lb check valves):

- Minimum 20 PSI
- Maximum 80 PSI

### Chart is for 28-0-0 Fertilizer @ 70°

- Heavier fertilizers (like 10-34-0) will have 5-15% less flow than chart indicates for a certain pressure
- Cold fertilizers will cause system pressure to increase at a given application rate.
- Tower Electric Pump Systems will have reduced flow and increased electrical current draw due to cold fertilizer increasing operating pressure. **Use the largest orifice possible for cold weather operation.**

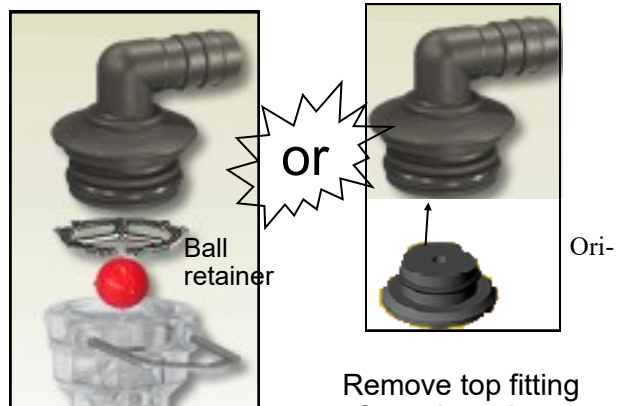

If using a metering orifice in the flow indicator, the orifice replaces the ball retainer. If not using an orifice here, the ball retainer must be in place.

Remove top fitting of each column. Then push the metering orifice into bottom of each outlet fitting.

All application rates (gallons/acres) are estimates based on 0-28-0 (10.65 lbs/gallon) at 70 degrees F.

# Check Valves

## 10 lb check valve with 3/8" hose barbs

The recommended check valve for most **PumpRight** installations is the 10 lb check with 3/8" hose barbs. This works with 3/8" rubber hose which SurePoint recommends for most applications over 10 GPA on 30" rows. The recommended minimum system operating pressure for this check is 20 psi, to ensure all checks open fully.

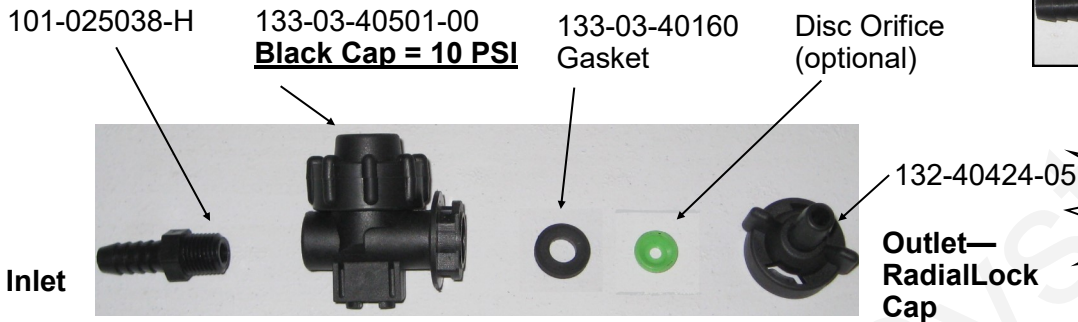

**B**  
Components  
Liquid



FLOW →

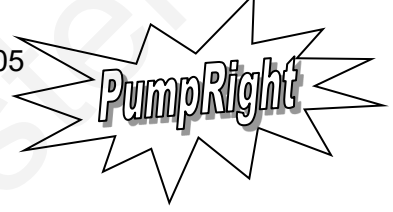

## 4 lb check valve with 1/4" quick connect fittings

4 lb check valves are typically used with **electric pump systems**. SurePoint recommends this valve for use with 1/4" tubing applying up to 10 GPA on 30" rows. The recommended minimum system operating pressure for this check is 10 psi, to ensure all checks open fully.



FLOW →

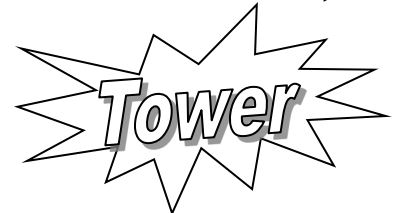

## Special Purpose Check Valve Assemblies

Assembly Part Number	Description	Suggested Uses (30" rows)
136-10-04QC04QC	1/4" QC x 1/4" QC 10 lb	< 10 GPA with <b>PumpRight</b> & 1/4" Tubing
136-10-06QC06QC	3/8" QC x 3/8" QC 10 lb	With 3/8" tubing plumbing
136-04-06HB06HB	3/8" HB x 3/8" HB 4 lb	> 10 GPA with <b>Electric Pumps</b>
136-04-08HB08HB	1/2" HB x 1/2" HB 4 lb	> 50 GPA with <b>PumpRight</b>
136-10-08HB08HB	1/2" HB x 1/2" HB 10 lb	> 50 GPA with <b>PumpRight</b>

# Colored Disc Orifice Chart for 30" rows

# B

Components  
Liquid

## 30" Spacing

Orifice Color (Approx Size)	PSI	Gal/Min 28-0-0	MPH						
			4.0	4.5	5.0	5.5	6.0	6.5	7.0
Pink (24)	10	0.033	1.62	1.44	1.30	1.18	1.08	1.00	0.93
	20	0.046	2.28	2.02	1.82	1.66	1.52	1.40	1.30
	30	0.057	2.80	2.49	2.24	2.04	1.87	1.73	1.60
	40	0.065	3.24	2.88	2.59	2.36	2.16	1.99	1.85
	50	0.073	3.64	3.23	2.91	2.64	2.42	2.24	2.08
	60	0.081	3.99	3.54	3.19	2.90	2.66	2.45	2.28
Gray (30)	10	0.050	2.50	2.22	2.00	1.82	1.66	1.54	1.43
	20	0.072	3.55	3.15	2.84	2.58	2.37	2.18	2.03
	30	0.088	4.34	3.85	3.47	3.15	2.89	2.67	2.48
	40	0.101	4.99	4.44	4.00	3.63	3.33	3.07	2.85
	50	0.112	5.56	4.95	4.45	4.05	3.71	3.42	3.18
	60	0.124	6.13	5.45	4.91	4.46	4.09	3.77	3.50
Black (35)	10	0.070	3.46	3.08	2.77	2.52	2.31	2.13	1.98
	20	0.098	4.86	4.32	3.89	3.54	3.24	2.99	2.78
	30	0.120	5.96	5.30	4.77	4.33	3.97	3.67	3.40
	40	0.139	6.88	6.11	5.50	5.00	4.58	4.23	3.93
	50	0.156	7.71	6.85	6.17	5.61	5.14	4.74	4.41
	60	0.170	8.41	7.48	6.73	6.12	5.61	5.18	4.81
Brown (41)	10	0.094	4.64	4.13	3.71	3.38	3.10	2.86	2.65
	20	0.132	6.53	5.80	5.22	4.75	4.35	4.02	3.73
	30	0.162	8.02	7.13	6.41	5.83	5.34	4.93	4.58
	40	0.187	9.24	8.22	7.39	6.72	6.16	5.69	5.28
	50	0.209	10.34	9.19	8.27	7.52	6.89	6.36	5.91
	60	0.228	11.30	10.05	9.04	8.22	7.53	6.95	6.46
Orange (46)	10	0.119	5.91	5.26	4.73	4.30	3.94	3.64	3.38
	20	0.169	8.37	7.44	6.69	6.08	5.58	5.15	4.78
	30	0.207	10.25	9.11	8.20	7.45	6.83	6.31	5.86
	40	0.239	11.83	10.51	9.46	8.60	7.88	7.28	6.76
	50	0.267	13.23	11.76	10.58	9.62	8.82	8.14	7.56
	60	0.293	14.50	12.89	11.60	10.55	9.67	8.92	8.29
Maroon (52)	10	0.149	7.36	6.54	5.89	5.35	4.91	4.53	4.21
	20	0.210	10.38	9.23	8.31	7.55	6.92	6.39	5.93
	30	0.257	12.70	11.29	10.16	9.24	8.47	7.82	7.26
	40	0.296	14.67	13.04	11.74	10.67	9.78	9.03	8.39
	50	0.332	16.43	14.60	13.14	11.95	10.95	10.11	9.39
	60	0.363	17.96	15.96	14.37	13.06	11.97	11.05	10.26
Red (63)	10	0.218	10.78	9.58	8.62	7.84	7.18	6.63	6.16
	20	0.307	15.20	13.51	12.16	11.05	10.13	9.35	8.69
	30	0.376	18.62	16.55	14.89	13.54	12.41	11.46	10.64
	40	0.435	21.51	19.12	17.21	15.64	14.34	13.24	12.29
	50	0.486	24.05	21.38	19.24	17.49	16.03	14.80	13.74
	60	0.532	26.33	23.40	21.06	19.15	17.55	16.20	15.04
Blue (80)	10	0.351	17.39	15.46	13.91	12.65	11.59	10.70	9.94
	20	0.496	24.57	21.84	19.66	17.87	16.38	15.12	14.04
	30	0.608	30.09	26.75	24.08	21.89	20.06	18.52	17.20
	40	0.702	34.74	30.88	27.79	25.26	23.16	21.38	19.85
	50	0.785	38.86	34.54	31.08	28.26	25.90	23.91	22.20
	60	0.859	42.53	37.81	34.03	30.93	28.36	26.18	24.31
Yellow (95)	10	0.506	25.06	22.27	20.05	18.22	16.70	15.42	14.32
	20	0.715	35.39	31.46	28.32	25.74	23.60	21.78	20.23
	30	0.876	43.37	38.55	34.69	31.54	28.91	26.69	24.78
	40	1.009	49.94	44.39	39.95	36.32	33.29	30.73	28.54
	50	1.133	56.07	49.84	44.86	40.78	37.38	34.51	32.04
	60	1.239	61.33	54.51	49.06	44.60	40.88	37.74	35.04
Green (110)	10	0.686	33.95	30.18	27.16	24.69	22.63	20.89	19.40
	20	0.973	48.19	42.83	38.55	35.04	32.12	29.65	27.53
	30	1.186	58.70	52.18	46.96	42.69	39.13	36.12	33.54
	40	1.372	67.90	60.35	54.32	49.38	45.27	41.78	38.80
	50	1.531	75.78	67.36	60.63	55.12	50.52	46.64	43.30
	60	1.681	83.23	73.98	66.58	60.53	55.49	51.22	47.56

### Tower Electric Pump Pressure Recommendations (with 4 lb check valves):

- Minimum 10 PSI
- Maximum 30 PSI (The pumps will operate up to 60 PSI, but the pump output decreases greatly at higher pressures. If pump will hit rate, high pressure is not a problem.)

### PumpRight Pressure Recommendations (with 10 lb check valves):

- Minimum 20 PSI
- Maximum 80 PSI

### Chart is for 28-0-0 Fertilizer @ 70°

- Heavier fertilizers (like 10-34-0) will have 5-15% less flow than chart indicates for a certain pressure
- Cold fertilizers will cause system pressure to increase at a given application rate.
- Tower Electric Pump Systems will have reduced flow and increased electrical current draw due to cold fertilizer increasing operating pressure. **Use the largest orifice possible for cold weather operation.**

Colored Disc Orifice assembles under the check valve cap in most cases. (Drop the orifice with the hole down into the cap, then put the gasket on top of it.) The orifice can also be installed in a manifold (common on grain drills).

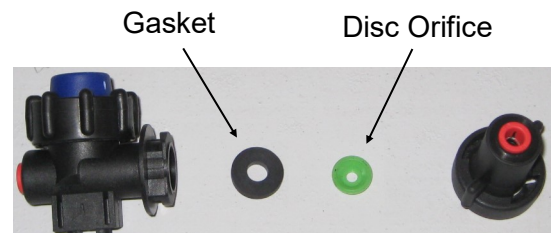

FLOW → 1/4 Turn Cap is Outlet

# Colored Disc Orifice Chart Common Grain Drill Row Spacings



## 7.5" Spacing

Orifice Color (Approx Size)	PSI	Gal/Min	MPH						
		28-0-0	4.0	4.5	5.0	5.5	6.0	6.5	7.0
Pink (24)	10	0.033	6.5	5.8	5.2	4.7	4.3	4.0	3.7
	20	0.046	9.1	8.1	7.3	6.6	6.1	5.6	5.2
	30	0.057	11.2	10.0	9.0	8.2	7.5	6.9	6.4
	40	0.065	13.0	11.5	10.4	9.4	8.6	8.0	7.4
	50	0.073	14.5	12.9	11.6	10.6	9.7	8.9	8.3
	60	0.081	15.9	14.2	12.8	11.6	10.6	9.8	9.1
Gray (30)	10	0.050	10.0	8.9	8.0	7.3	6.7	6.1	5.7
	20	0.072	14.2	12.6	11.4	10.3	9.5	8.7	8.1
	30	0.088	17.3	15.4	13.9	12.6	11.6	10.7	9.9
	40	0.101	20.0	17.8	16.0	14.5	13.3	12.3	11.4
	50	0.112	22.3	19.8	17.8	16.2	14.8	13.7	12.7
	60	0.124	24.5	21.8	19.6	17.8	16.4	15.1	14.0
Black (35)	10	0.070	13.8	12.3	11.1	10.1	9.2	8.5	7.9
	20	0.098	19.4	17.3	15.6	14.1	13.0	12.0	11.1
	30	0.120	23.8	21.2	19.1	17.3	15.9	14.7	13.6
	40	0.139	27.5	24.5	22.0	20.0	18.3	16.9	15.7
	50	0.156	30.8	27.4	24.7	22.4	20.6	19.0	17.6
	60	0.170	33.6	29.9	26.9	24.5	22.4	20.7	19.2
Brown (41)	10	0.094	19	17	15	14	12	11	11
	20	0.132	26	23	21	19	17	16	15
	30	0.162	32	29	26	23	21	20	18
	40	0.187	37	33	30	27	25	23	21
	50	0.209	41	37	33	30	28	25	24
	60	0.228	45	40	36	33	30	28	26
Orange (46)	10	0.119	24	21	19	17	16	15	14
	20	0.169	33	30	27	24	22	21	19
	30	0.207	41	36	33	30	27	25	23
	40	0.239	47	42	38	34	32	29	27
	50	0.267	53	47	42	38	35	33	30
	60	0.293	58	52	46	42	39	36	33
Maroon (52)	10	0.149	29	26	24	21	20	18	17
	20	0.210	42	37	33	30	28	26	24
	30	0.257	51	45	41	37	34	31	29
	40	0.296	59	52	47	43	39	36	34
	50	0.332	66	58	53	48	44	40	38
	60	0.363	72	64	57	52	48	44	41
Red (63)	10	0.218	43	38	34	31	29	27	25
	20	0.307	61	54	49	44	41	37	35
	30	0.376	74	66	60	54	50	46	43
	40	0.435	86	76	69	63	57	53	49
	50	0.486	96	86	77	70	64	59	55
	60	0.532	105	94	84	77	70	65	60
Blue (80)	10	0.351	70	62	56	51	46	43	40
	20	0.496	98	87	79	71	66	60	56
	30	0.608	120	107	96	88	80	74	69
	40	0.702	139	124	111	101	93	86	79
	50	0.785	155	138	124	113	104	96	89
	60	0.859	170	151	136	124	113	105	97
Yellow (95)	10	0.506	100	89	80	73	67	62	57
	20	0.715	142	126	113	103	94	87	81
	30	0.876	173	154	139	126	116	107	99
	40	1.009	200	178	160	145	133	123	114
	50	1.133	224	199	179	163	150	138	128
	60	1.239	245	218	196	178	164	151	140

## 10" Spacing

Orifice Color (Approx Size)	PSI	Gal/Min	MPH						
		28-0-0	4.0	4.5	5.0	5.5	6.0	6.5	7.0
Pink (24)	10	0.033	4.9	4.3	3.9	3.5	3.2	3.0	2.8
	20	0.046	6.8	6.1	5.5	5.0	4.6	4.2	3.9
	30	0.057	8.4	7.5	6.7	6.1	5.6	5.2	4.8
	40	0.065	9.7	8.6	7.8	7.1	6.5	6.0	5.6
	50	0.073	10.9	9.7	8.7	7.9	7.3	6.7	6.2
	60	0.081	12.0	10.6	9.6	8.7	8.0	7.4	6.8
Gray (30)	10	0.050	7.5	6.7	6.0	5.4	5.0	4.6	4.3
	20	0.072	10.6	9.5	8.5	7.7	7.1	6.6	6.1
	30	0.088	13.0	11.6	10.4	9.5	8.7	8.0	7.4
	40	0.101	15.0	13.3	12.0	10.9	10.0	9.2	8.6
	50	0.112	16.7	14.8	13.4	12.1	11.1	10.3	9.5
	60	0.124	18.4	16.4	14.7	13.4	12.3	11.3	10.5
Black (35)	10	0.070	10.4	9.2	8.3	7.6	6.9	6.4	5.9
	20	0.098	14.6	13.0	11.7	10.6	9.7	9.0	8.3
	30	0.120	17.9	15.9	14.3	13.0	11.9	11.0	10.2
	40	0.139	20.6	18.3	16.5	15.0	13.8	12.7	11.8
	50	0.156	23.1	20.6	18.5	16.8	15.4	14.2	13.2
	60	0.170	25.2	22.4	20.2	18.4	16.8	15.5	14.4
Brown (41)	10	0.094	14	12	11	10	9	9	8
	20	0.132	20	17	16	14	13	12	11
	30	0.162	24	21	19	17	16	15	14
	40	0.187	28	25	22	20	18	17	16
	50	0.209	31	28	25	23	21	19	18
	60	0.228	34	30	27	25	23	21	19
Orange (46)	10	0.119	18	16	14	13	12	11	10
	20	0.169	25	22	20	18	17	15	14
	30	0.207	31	27	25	22	21	19	18
	40	0.239	35	32	28	26	24	22	20
	50	0.267	40	35	32	29	26	24	23
	60	0.293	43	39	35	32	29	27	25
Maroon (52)	10	0.149	22	20	18	16	15	14	13
	20	0.210	31	28	25	23	21	19	18
	30	0.257	38	34	30	28	25	23	22
	40	0.296	44	39	35	32	29	27	25
	50	0.332	49	44	39	36	33	30	28
	60	0.363	54	48	43	39	36	33	31
Red (63)	10	0.218	32	29	26	24	22	20	18
	20	0.307	46	41	36	33	30	28	26
	30	0.376	56	50	45	41	37	34	32
	40	0.435	65	57	52	47	43	40	37
	50	0.486	72	64	58	52	48	44	41
	60	0.532	79	70	63	57	53	49	45
Blue (80)	10	0.351	52	46	42	38	35	32	30
	20	0.496	74	66	59	54	49	45	42
	30	0.608	90	80	72	66	60	56	52
	40	0.702	104	93	83	76	69	64	60
	50	0.785	117	104	93	85	78	72	67
	60	0.859	128	113	102	93	85	79	73
Yellow (95)	10	0.506	75	67	60	55	50	46	43
	20	0.715	106	94	85	77	71	65	61
	30	0.876	130	116	104	95	87	80	74
	40	1.009	150	133	120	109	100	92	86
	50	1.133	168	150	135	122	112	104	96
	60	1.239	184	164	147	134	123	113	105

All application rates (gallons/acres) are estimates based on 0-28-0 (10.65 lbs/gallon) at 70 degrees F

All application rates (gallons/acres) are estimates based on 0-28-0 (10.65 lbs/gallon) at 70 degrees F



# Colored Disc Orifice Chart



## 15" Spacing

Orifice Color (Approx Size)	PSI	Gal/Min 28-0-0	MPH						
			4.0	4.5	5.0	5.5	6.0	6.5	7.0
Pink (24)	10	0.033	3.2	2.9	2.6	2.4	2.2	2.0	1.9
	20	0.046	4.6	4.0	3.6	3.3	3.0	2.8	2.6
	30	0.057	5.6	5.0	4.5	4.1	3.7	3.5	3.2
	40	0.065	6.5	5.8	5.2	4.7	4.3	4.0	3.7
	50	0.073	7.3	6.5	5.8	5.3	4.8	4.5	4.2
	60	0.081	8.0	7.1	6.4	5.8	5.3	4.9	4.6
Gray (30)	10	0.050	5.0	4.4	4.0	3.6	3.3	3.1	2.9
	20	0.072	7.1	6.3	5.7	5.2	4.7	4.4	4.1
	30	0.088	8.7	7.7	6.9	6.3	5.8	5.3	5.0
	40	0.101	10.0	8.9	8.0	7.3	6.7	6.1	5.7
	50	0.112	11.1	9.9	8.9	8.1	7.4	6.8	6.4
	60	0.124	12.3	10.9	9.8	8.9	8.2	7.5	7.0
Black (35)	10	0.070	6.9	6.2	5.5	5.0	4.6	4.3	4.0
	20	0.098	9.7	8.6	7.8	7.1	6.5	6.0	5.6
	30	0.120	11.9	10.6	9.5	8.7	7.9	7.3	6.8
	40	0.139	13.8	12.2	11.0	10.0	9.2	8.5	7.9
	50	0.156	15.4	13.7	12.3	11.2	10.3	9.5	8.8
	60	0.170	16.8	15.0	13.5	12.2	11.2	10.4	9.6
Brown (41)	10	0.094	9.3	8.3	7.4	6.8	6.2	5.7	5.3
	20	0.132	13.1	11.6	10.4	9.5	8.7	8.0	7.5
	30	0.162	16.0	14.3	12.8	11.7	10.7	9.9	9.2
	40	0.187	18.5	16.4	14.8	13.4	12.3	11.4	10.6
	50	0.209	20.7	18.4	16.5	15.0	13.8	12.7	11.8
	60	0.228	22.6	20.1	18.1	16.4	15.1	13.9	12.9
Orange (46)	10	0.119	11.8	10.5	9.5	8.6	7.9	7.3	6.8
	20	0.169	16.7	14.9	13.4	12.2	11.2	10.3	9.6
	30	0.207	20.5	18.2	16.4	14.9	13.7	12.6	11.7
	40	0.239	23.7	21.0	18.9	17.2	15.8	14.6	13.5
	50	0.267	26.5	23.5	21.2	19.2	17.6	16.3	15.1
	60	0.293	29.0	25.8	23.2	21.1	19.3	17.8	16.6
Maroon (52)	10	0.149	15	13	12	11	10	9	8
	20	0.210	21	18	17	15	14	13	12
	30	0.257	25	23	20	18	17	16	15
	40	0.296	29	26	23	21	20	18	17
	50	0.332	33	29	26	24	22	20	19
	60	0.363	36	32	29	26	24	22	21
Red (63)	10	0.218	22	19	17	16	14	13	12
	20	0.307	30	27	24	22	20	19	17
	30	0.376	37	33	30	27	25	23	21
	40	0.435	43	38	34	31	29	26	25
	50	0.486	48	43	38	35	32	30	27
	60	0.532	53	47	42	38	35	32	30
Blue (80)	10	0.351	35	31	28	25	23	21	20
	20	0.496	49	44	39	36	33	30	28
	30	0.608	60	54	48	44	40	37	34
	40	0.702	69	62	56	51	46	43	40
	50	0.785	78	69	62	57	52	48	44
	60	0.859	85	76	68	62	57	52	49
Yellow (95)	10	0.506	50	45	40	36	33	31	29
	20	0.715	71	63	57	51	47	44	40
	30	0.876	87	77	69	63	58	53	50
	40	1.009	100	89	80	73	67	61	57
	50	1.133	112	100	90	82	75	69	64
	60	1.239	123	109	98	89	82	75	70
Green (110)	10	0.686	68	60	54	49	45	42	39
	20	0.973	96	86	77	70	64	59	55
	30	1.186	117	104	94	85	78	72	67
	40	1.372	136	121	109	99	91	84	78
	50	1.531	152	135	121	110	101	93	87
	60	1.681	166	148	133	121	111	102	95
White (125)	10	0.867	86	76	69	62	57	53	49
	20	1.230	122	108	97	89	81	75	70
	30	1.504	149	132	119	108	99	92	85
	40	1.735	172	153	137	125	114	106	98
	50	1.938	192	171	153	140	128	118	110
	60	2.124	210	187	168	153	140	129	120
Lime Green (156)	10	1.372	136	121	109	99	91	84	78
	20	1.947	193	171	154	140	128	119	110
	30	2.381	236	209	189	171	157	145	135
	40	2.752	272	242	218	198	182	168	156
	50	3.071	304	270	243	221	203	187	174
	60	3.363	333	296	266	242	222	205	190

All application rates (gallons/acres) are estimates based on 0-28-0 (10.65 lbs/gallon) at 70 degrees F.

## 20" Spacing

Orifice Color (Approx Size)	PSI	Gal/Min 28-0-0	MPH						
			4.0	4.5	5.0	5.5	6.0	6.5	7.0
Pink (24)	10	0.033	2.4	2.2	1.9	1.8	1.6	1.5	1.4
	20	0.046	3.4	3.0	2.7	2.5	2.3	2.1	2.0
	30	0.057	4.2	3.7	3.4	3.1	2.8	2.6	2.4
	40	0.065	4.9	4.3	3.9	3.5	3.2	3.0	2.8
	50	0.073	5.5	4.8	4.4	4.0	3.6	3.4	3.1
	60	0.081	6.0	5.3	4.8	4.3	4.0	3.7	3.4
Gray (30)	10	0.050	3.7	3.3	3.0	2.7	2.5	2.3	2.1
	20	0.072	5.3	4.7	4.3	3.9	3.5	3.3	3.0
	30	0.088	6.5	5.8	5.2	4.7	4.3	4.0	3.7
	40	0.101	7.5	6.7	6.0	5.4	5.0	4.6	4.3
	50	0.112	8.3	7.4	6.7	6.1	5.6	5.1	4.8
	60	0.124	9.2	8.2	7.4	6.7	6.1	5.7	5.3
Black (35)	10	0.070	5.2	4.6	4.2	3.8	3.5	3.2	3.0
	20	0.098	7.3	6.5	5.8	5.3	4.9	4.5	4.2
	30	0.120	8.9	7.9	7.1	6.5	6.0	5.5	5.1
	40	0.139	10.3	9.2	8.3	7.5	6.9	6.3	5.9
	50	0.156	11.6	10.3	9.3	8.4	7.7	7.1	6.6
	60	0.170	12.6	11.2	10.1	9.2	8.4	7.8	7.2
Brown (41)	10	0.094	7.0	6.2	5.6	5.1	4.6	4.3	4.0
	20	0.132	9.8	8.7	7.8	7.1	6.5	6.0	5.6
	30	0.162	12.0	10.7	9.6	8.7	8.0	7.4	6.9
	40	0.187	13.9	12.3	11.1	10.1	9.2	8.5	7.9
	50	0.209	15.5	13.8	12.4	11.3	10.3	9.5	8.9
	60	0.228	17.0	15.1	13.6	12.3	11.3	10.4	9.7
Orange (46)	10	0.119	8.9	7.9	7.1	6.5	5.9	5.5	5.1
	20	0.169	12.6	11.2	10.0	9.1	8.4	7.7	7.2
	30	0.207	15.4	13.7	12.3	11.2	10.3	9.5	8.8
	40	0.239	17.7	15.8	14.2	12.9	11.8	10.9	10.1
	50	0.267	19.8	17.6	15.9	14.4	13.2	12.2	11.3
	60	0.293	21.7	19.3	17.4	15.8	14.5	13.4	12.4
Maroon (52)	10	0.149	11	10	9	8	7	7	6
	20	0.210	16	14	12	11	10	10	9
	30	0.257	19	17	15	14	13	12	11
	40	0.296	22	20	18	16	15	14	13
	50	0.332	25	22	20	18	16	15	14
	60	0.363	27	24	22	20	18	17	15
Red (63)	10	0.218	16	14	13	12	11	10	9
	20	0.307	23	20	18	17	15	14	13
	30	0.376	28	25	22	20	19	17	16
	40	0.435	32	29	26	23	22	20	18
	50	0.486	36	32	29	26	24	22	21
	60	0.532	39	35	32	29	26	24	23
Blue (80)	10	0.351	26	23	21	19	17	16	15
	20	0.496	37	33	29	27	25	23	21
	30	0.608	45	40	36	33	30	28	26
	40	0.702	52	46	42	38	35	32	30
	50	0.785	58	52	47	42	39	36	33
	60	0.859	64	57	51	46	43	39	36
Yellow (95)	10	0.506	38	33	30	27	25	23	21
	20	0.715	53	47	42	39	35	33	30
	30	0.876	65	58	52	47	43	40	37
	40	1.009	75	67	60	54	50	46	43
	50	1.133	84	75	67	61	56	52	48
	60	1.239	92	82	74	67	61	57	53
Green (110)	10	0.686	51	45	41	37	34	31	29
	20	0.973	72	64	58	53	48	44	41
	30	1.186	88	78	70	64	59	54	50
	40	1.372	102	91	81	74	68	63	58
	50	1.531	114	101	91	83	76	70	65
	60	1.681	125	111	100	91	83	77	71
White (125)	10	0.867	64	57	52	47	43	40	37
	20	1.230	91	81	73	66	61	56	52
	30	1.504	112	99	89	81	74	69	64
	40	1.735	129	114	103	94	86	79	74
	50	1.938	144	128	115	105	96	89	82
	60	2.124	158	140	126	115	105	97	90
Lime Green (156)	10	1.372	102	91	81	74	68	63	58
	20	1.947	145	128	116	105	96	89	83
	30	2.381	177	157	141	129	118	109	101
	40	2.752	204	182	163	149	136	126	117
	50	3.071	228	203	182	166	152	140	130
	60	3.363	250	222	200	182	166	154	143

All application rates (gallons/acres) are estimates based on 0-28-0 (10.65 lbs/gallon) at 70 degrees F.



# Colored Disc Orifice Chart

# B

Components  
Liquid

22" Spacing

22" Spacing

22" Spacing

Orifice Color (Approx Size)	PSI	MPH							
		Gal/Min 28-0-0	4.0	4.5	5.0	5.5	6.0	6.5	7.0
Pink (24)	10	0.033	2.2	2.0	1.8	1.6	1.5	1.4	1.3
	20	0.046	3.1	2.8	2.5	2.3	2.1	1.9	1.8
	30	0.057	3.8	3.4	3.1	2.8	2.5	2.4	2.2
	40	0.065	4.4	3.9	3.5	3.2	2.9	2.7	2.5
	50	0.073	5.0	4.4	4.0	3.6	3.3	3.1	2.8
60	0.081	5.4	4.8	4.3	4.0	3.6	3.3	3.1	
Gray (30)	10	0.050	3.4	3.0	2.7	2.5	2.3	2.1	1.9
	20	0.072	4.8	4.3	3.9	3.5	3.2	3.0	2.8
	30	0.088	5.9	5.3	4.7	4.3	3.9	3.6	3.4
	40	0.101	6.8	6.1	5.4	5.0	4.5	4.2	3.9
	50	0.112	7.6	6.7	6.1	5.5	5.1	4.7	4.3
60	0.124	8.4	7.4	6.7	6.1	5.6	5.1	4.8	
Black (35)	10	0.070	4.7	4.2	3.8	3.4	3.1	2.9	2.7
	20	0.098	6.6	5.9	5.3	4.8	4.4	4.1	3.8
	30	0.120	8.1	7.2	6.5	5.9	5.4	5.0	4.6
	40	0.139	9.4	8.3	7.5	6.8	6.3	5.8	5.4
	50	0.156	10.5	9.3	8.4	7.6	7.0	6.5	6.0
60	0.170	11.5	10.2	9.2	8.3	7.6	7.1	6.6	
Brown (41)	10	0.094	6.3	5.6	5.1	4.6	4.2	3.9	3.6
	20	0.132	8.9	7.9	7.1	6.5	5.9	5.5	5.1
	30	0.162	10.9	9.7	8.7	8.0	7.3	6.7	6.2
	40	0.187	12.6	11.2	10.1	9.2	8.4	7.8	7.2
	50	0.209	14.1	12.5	11.3	10.3	9.4	8.7	8.1
60	0.228	15.4	13.7	12.3	11.2	10.3	9.5	8.8	
Orange (46)	10	0.119	8.1	7.2	6.5	5.9	5.4	5.0	4.6
	20	0.169	11.4	10.1	9.1	8.3	7.6	7.0	6.5
	30	0.207	14.0	12.4	11.2	10.2	9.3	8.6	8.0
	40	0.239	16.1	14.3	12.9	11.7	10.8	9.9	9.2
	50	0.267	18.0	16.0	14.4	13.1	12.0	11.1	10.3
60	0.293	19.8	17.6	15.8	14.4	13.2	12.2	11.3	
Maroon (52)	10	0.149	10	9	8	7	7	6	6
	20	0.210	14	13	11	10	9	9	8
	30	0.257	17	15	14	13	12	11	10
	40	0.296	20	18	16	15	13	12	11
	50	0.332	22	20	18	16	15	14	13
60	0.363	24	22	20	18	16	15	14	
Red (63)	10	0.218	15	13	12	11	10	9	8
	20	0.307	21	18	17	15	14	13	12
	30	0.376	25	23	20	18	17	16	15
	40	0.435	29	26	23	21	20	18	17
	50	0.486	33	29	26	24	22	20	19
60	0.532	36	32	29	26	24	22	21	
Blue (80)	10	0.351	24	21	19	17	16	15	14
	20	0.496	34	30	27	24	22	21	19
	30	0.608	41	36	33	30	27	25	23
	40	0.702	47	42	38	34	32	29	27
	50	0.785	53	47	42	39	35	33	30
60	0.859	58	52	46	42	39	36	33	
Yellow (95)	10	0.506	34	30	27	25	23	21	20
	20	0.715	48	43	39	35	32	30	28
	30	0.876	59	53	47	43	39	36	34
	40	1.009	68	61	54	50	45	42	39
	50	1.133	76	68	61	56	51	47	44
60	1.239	84	74	67	61	56	51	48	
Green (110)	10	0.686	46	41	37	34	31	28	26
	20	0.973	66	58	53	48	44	40	38
	30	1.186	80	71	64	58	53	49	46
	40	1.372	93	82	74	67	62	57	53
	50	1.531	103	92	83	75	69	64	59
60	1.681	113	101	91	83	76	70	65	
White (125)	10	0.867	59	52	47	43	39	36	33
	20	1.230	83	74	66	60	55	51	47
	30	1.504	102	90	81	74	68	62	58
	40	1.735	117	104	94	85	78	72	67
	50	1.938	131	116	105	95	87	81	75
60	2.124	143	127	115	104	96	88	82	
Lime Green (156)	10	1.372	93	82	74	67	62	57	53
	20	1.947	131	117	105	96	88	81	75
	30	2.381	161	143	129	117	107	99	92
	40	2.752	186	165	149	135	124	114	106
	50	3.071	207	184	166	151	138	128	118
60	3.363	227	202	182	165	151	140	130	

All application rates (gallons/acre) are estimates based on 0-28-0 (10.65 lbs/gallon) at 70 degrees F.

36" Spacing

36" Spacing

36" Spacing

Orifice Color (Approx Size)	PSI	MPH							
		Gal/Min 28-0-0	4.0	4.5	5.0	5.5	6.0	6.5	7.0
Pink (24)	10	0.033	1.4	1.2	1.1	1.0	0.9	0.8	0.8
	20	0.046	1.9	1.7	1.5	1.4	1.3	1.2	1.1
	30	0.057	2.3	2.1	1.9	1.7	1.6	1.4	1.3
	40	0.065	2.7	2.4	2.2	2.0	1.8	1.7	1.5
	50	0.073	3.0	2.7	2.4	2.2	2.0	1.9	1.7
60	0.081	3.3	3.0	2.7	2.4	2.2	2.0	1.9	
Gray (30)	10	0.050	2.1	1.8	1.7	1.5	1.4	1.3	1.2
	20	0.072	3.0	2.6	2.4	2.2	2.0	1.8	1.7
	30	0.088	3.6	3.2	2.9	2.6	2.4	2.2	2.1
	40	0.101	4.2	3.7	3.3	3.0	2.8	2.6	2.4
	50	0.112	4.6	4.1	3.7	3.4	3.1	2.9	2.6
60	0.124	5.1	4.5	4.1	3.7	3.4	3.1	2.9	
Black (35)	10	0.070	2.9	2.6	2.3	2.1	1.9	1.8	1.6
	20	0.098	4.1	3.6	3.2	2.9	2.7	2.5	2.3
	30	0.120	5.0	4.4	4.0	3.6	3.3	3.1	2.8
	40	0.139	5.7	5.1	4.6	4.2	3.8	3.5	3.3
	50	0.156	6.4	5.7	5.1	4.7	4.3	4.0	3.7
60	0.170	7.0	6.2	5.6	5.1	4.7	4.3	4.0	
Brown (41)	10	0.094	3.9	3.4	3.1	2.8	2.6	2.4	2.2
	20	0.132	5.4	4.8	4.4	4.0	3.6	3.3	3.1
	30	0.162	6.7	5.9	5.3	4.9	4.5	4.1	3.8
	40	0.187	7.7	6.8	6.2	5.6	5.1	4.7	4.4
	50	0.209	8.6	7.7	6.9	6.3	5.7	5.3	4.9
60	0.228	9.4	8.4	7.5	6.8	6.3	5.8	5.4	
Orange (46)	10	0.119	4.9	4.4	3.9	3.6	3.3	3.0	2.8
	20	0.169	7.0	6.2	5.6	5.1	4.6	4.3	4.0
	30	0.207	8.5	7.6	6.8	6.2	5.7	5.3	4.9
	40	0.239	9.9	8.8	7.9	7.2	6.6	6.1	5.6
	50	0.267	11.0	9.8	8.8	8.0	7.3	6.8	6.3
60	0.293	12.1	10.7	9.7	8.8	8.1	7.4	6.9	
Maroon (52)	10	0.149	6	5	5	4	4	4	4
	20	0.210	9	8	7	6	6	5	5
	30	0.257	11	9	8	8	7	7	6
	40	0.296	12	11	10	9	8	8	7
	50	0.332	14	12	11	10	9	8	8
60	0.363	15	13	12	11	10	9	9	
Red (63)	10	0.218	9	8	7	7	6	6	5
	20	0.307	13	11	10	9	8	8	7
	30	0.376	16	14	12	11	10	10	9
	40	0.435	18	16	14	13	12	11	10
	50	0.486	20	18	16	15	13	12	11
60	0.532	22	20	18	16	15	14	13	
Blue (80)	10	0.351	14	13	12	11	10	9	8
	20	0.496	20	18	16	15	14	13	12
	30	0.608	25	22	20	18	17	15	14
	40	0.702	29	26	23	21	19	18	17
	50	0.785	32	29	26	24	22	20	19
60	0.859	35	32	28	26	24	22	20	
Yellow (95)	10	0.506	21	19	17	15	14	13	12
	20	0.715	29	26	24	21	20	18	17
	30	0.876	36	32	29	26	24	22	21
	40	1.009	42	37	33	30	28	26	24
	50	1.133	47	42	37	34	31	29	27
60	1.239	51	45	41	37	34	31	29	
Green (110)	10	0.686	28	25	23	21	19	17	16
	20	0.973	40	36	32	29	27	25	23
	30	1.186	49	43	39	36	33	30	28
	40	1.372	57	50	45	41	38	35	32
	50	1.531	63	56	51	46	42	3	

# Dual Metering Tube Plumbing Kits with Dual Check Valve

(For more information on metering tube, see [this article](http://www.SurePointag.com/cms/images/Metering-Tube-Maze_Reduced.pdf). ([http://www.SurePointag.com/cms/images/Metering-Tube-Maze\\_Reduced.pdf](http://www.SurePointag.com/cms/images/Metering-Tube-Maze_Reduced.pdf))

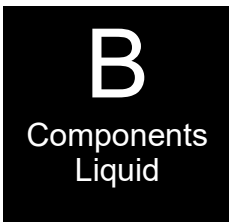

SurePoint dual metering tube plumbing kits are a great way to plumb a planter to apply starter fertilizer. They'll also work on other implements when applying low rates or high rates of fertilizer.

These plumbing kits will contain everything you need to distribute fertilizer from the flowmeter outlet down to the ground application device of your choice (not included).

These instructions will show you where all the pieces go. It will provide guidance on how much metering tube to use. There are some optional fittings included in each plumbing kit. These instructions will show you where and why you'd want to use the optional pieces.

The dual check valve assembly is a key piece in the dual metering tube design. In addition to a check valve to stop fertilizer from draining when the system is shut off, **each check valve has an on/off valve on top of it. These on / off valves allow the operator to turn on only tube 1, only tube 2, or both tube 1 and 2. This provides for three different application ranges**, which is especially helpful when using Black Label Zn fertilizer (or any other liquid) which has a highly variable viscosity based on temperature changes.

## Dual Advantage of Dual Metering Tube

Metering tube provides a larger passage-way diameter than a comparable orifice. For a 5 GPA rate on 30" rows, a size 0.046" orifice would be used. For the same rate a 0.110" meter tube that is 8' long would be used. This 8' tube with more than twice the diameter creates a fertilizer system resistant to plugging while providing excellent row to row distribution.

By using two metering tubes, the fertilizer system can handle Black Label ZN (or most other liquid solutions) and provide the proper system pressure as the fertilizer properties change due to temperature, mixtures and other factors.

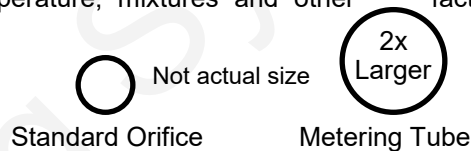

## Field Operation of Dual Metering Tube - Dual Check Valve System

The dual metering tube allows for three application rate ranges. Black Label ZN and other liquid fertilizers can have a widely variable viscosity range. Therefore, based on temperature, tank mixing and fertilizer batch, the best tube to use will change.

SurePoint recommends you start with the Green (or larger) tube ON only. This is the middle application range and is a good starting point. Conduct a test using the test speed mode to determine your system pressure. Recommended pressure is between 8 - 30 PSI. If pressure is below 8 psi, some check valves may not open and row to row distribution will be uneven. If pressure is too high, pump output will decrease and you may not reach the target rate.

**Start with green (or larger) tube ON, blue tube OFF:**

• **Pressure below 10 PSI: Turn green tube OFF and blue tube ON.**

**Pressure over 30 PSI: Turn BOTH tubes ON.**

(Other color tubes are available for different application rates.)

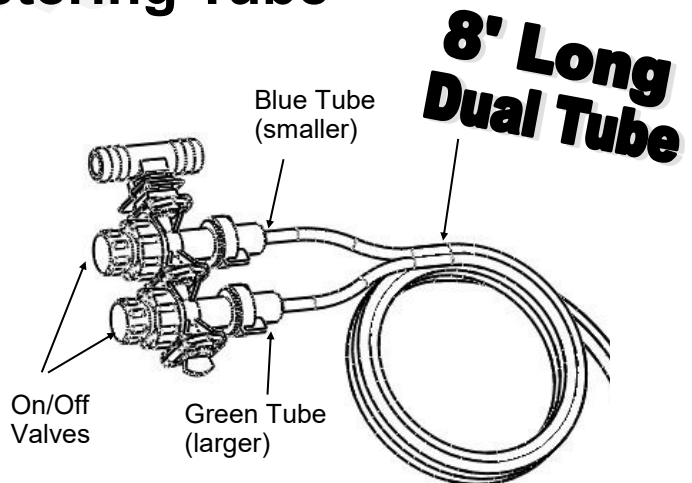

	GPA on 30" rows (approx, will vary)
Blue Tube	1.5 - 3
Green Tube	3 - 6
Blue & Green Tube	6 - 10
Minimum Recommended flow for Blue Tube (8 ft)	4 - 5 oz/min

**\*\* Ultra Low Rate Application** –For rates from 2-5 oz/min/row use a 12 foot length of metering tube. To calculate oz/min/row:  $Oz/min/row = (GPA \times MPH \times spacing \text{ (inches)}) \div 46.4$

## Dual Check Valve Plumbing Diagram

4 Row Planter Shown, add rows as necessary

136-04-200400, Dual 4 PSI check valve with 1/4" QC caps and 3/8" FPT inlet

101-075075038-HBT-M-W 3/4" HB x 3/4" HB x 3/8" MPT Tee

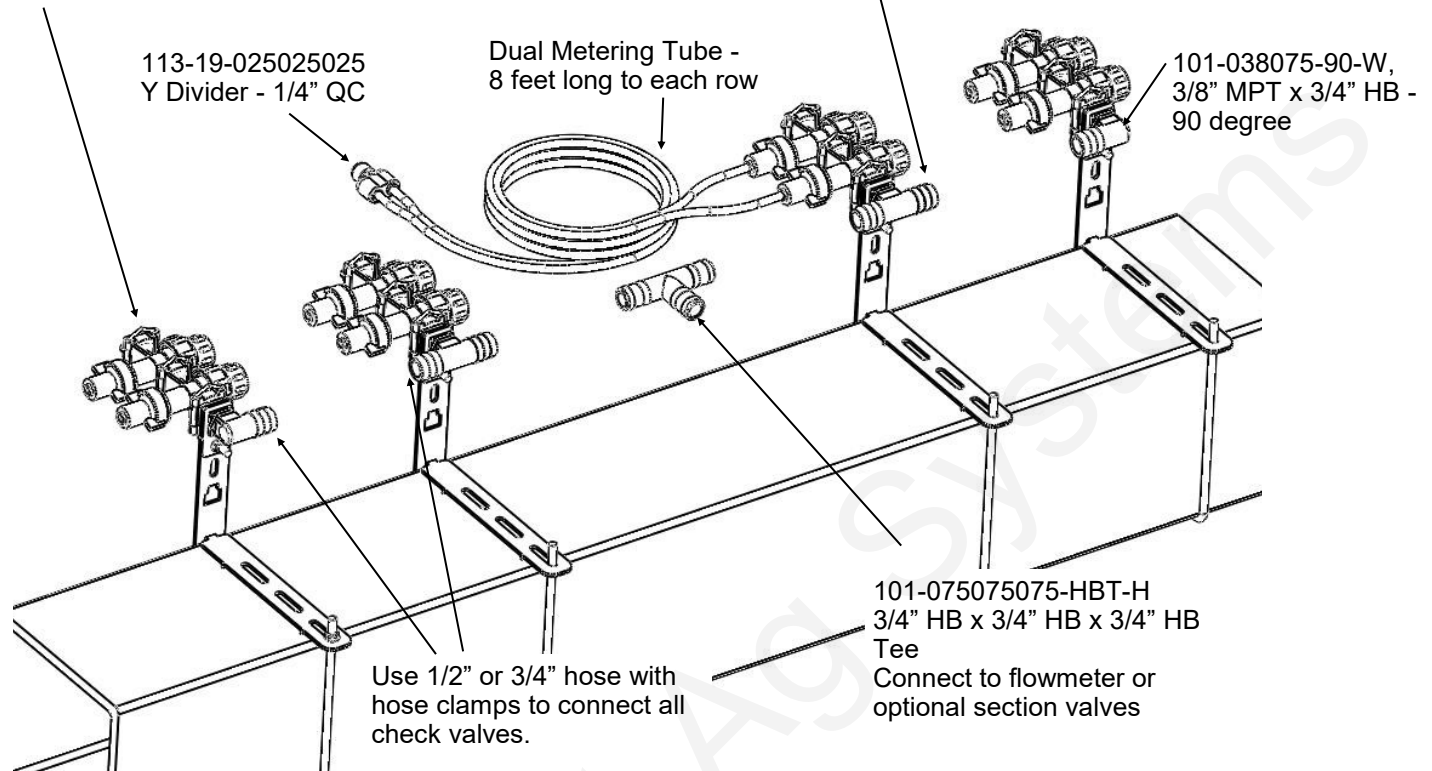

This is a general diagram showing the dual check valve assembly mounted on a planter toolbar. The check valve and bracket are very flexible in their mounting. The check valve can mount behind, directly over, or in front of the toolbar. The check valve can be put in the bracket facing up & down or sideways (shown). In addition the steel bracket could be rotated 90 degrees and clamp around the bar. The multiple slots in the bracket are used to mount to any tube 7x7 inches or smaller.

## Sectional Plumbing Diagram with Dual Check Valves

12 Row Planter Shown

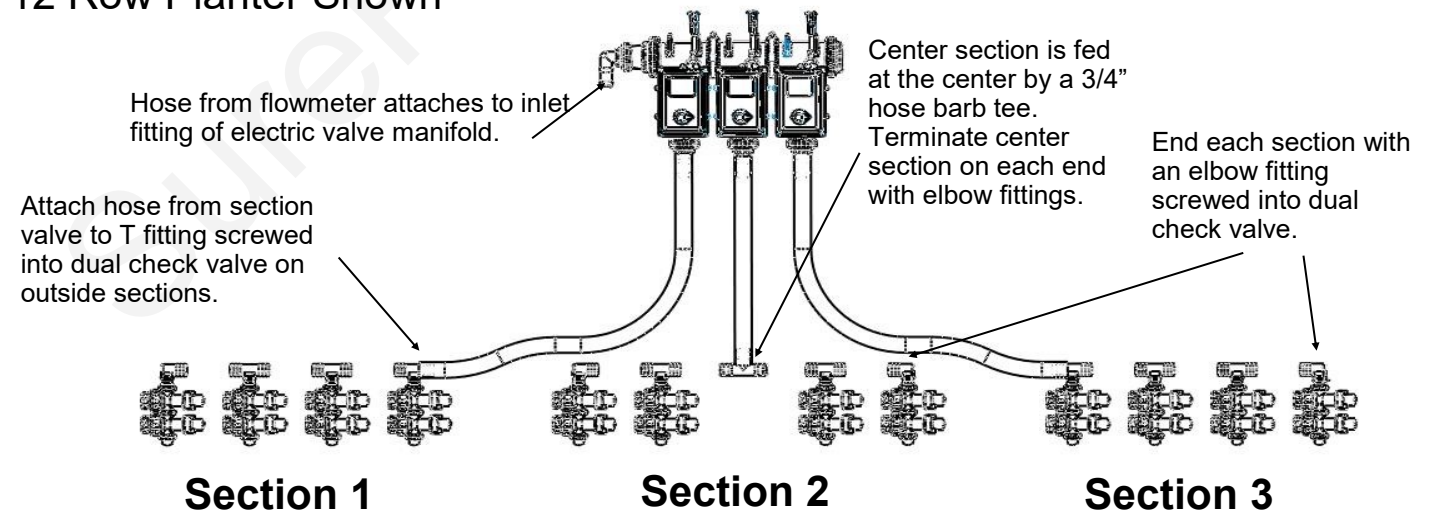

For a **2 section plumbing system**, omit the center section and plumb similar to the outside 2 sections.

# Dual Check Valve Assembly Steps

**B**  
Components  
Liquid

Follow these steps to mount each check valve to the steel bracket.

1. Screw the 3/8" MPT x 3/4" HB tee or elbow into the check valve using blue thread sealer. Orient the hose barb to run the 3/4" hose down the planter toolbar.
2. Insert the check valve into the "C" notch in the end of the bracket, according to how you want the check valve to be mounted on your planter. Orient the wire clips up or to the side for easiest access.
3. Slide the small "C" clamp bracket around the check valve to lock it in place.
4. Install the 1/4" carriage bolt and flange nut to secure the "C" clamp plate around the check valve.
5. Now, mount the check valve on the bar. Hold the check valve and long bracket assembly on the toolbar. Slide the tab on the front of the short bracket into the upper or lower notch on the long bracket.
6. Slide the L bolt into the appropriate slots on the brackets for your tube size. Tighten the 1/4" flange nuts to hold the bracket in place.

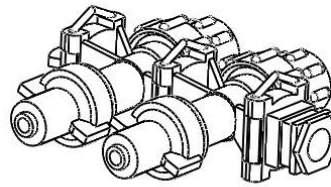

Clamp Bracket

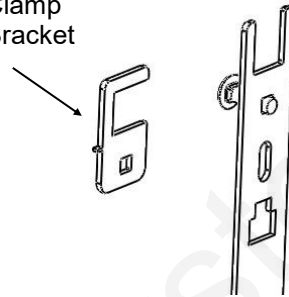

Elbow at end of section, Tee in mid-locations.

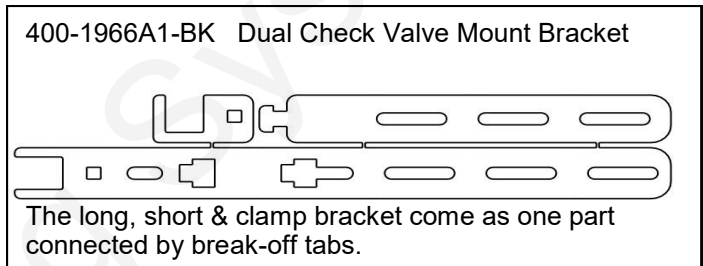

## Check Valve Mounting Options

The dual check valve mounting bracket is very flexible to fit many different planter configurations. Three options are shown here to illustrate some of the possibilities.

Example 1. Use the long bracket on the top of a bar. The check valve is mounted vertically. The liquid supply hose is run directly on the front side of the bar. The U-bolt is placed in slots to clamp on a 4x6 inch tube.

Example 2. Use the long bracket on the rear of a bar. The check valve is mounted over the top of the bar. The supply line would run above and behind the bar. The short bracket is placed in the notch to mount the check valve closer to the bar.

Example 3. Use the long bracket on the front of a 3x7 bar (vacuum tube on some planters). Mount the check valve hanging forward of the bar. The supply line will run directly over the bar. The excess bolt and bracket length can be cut off.

Short Bracket

Long Bracket

311-0408000800-05  
1/4" L Bolt

## Connection to Keeton Seed Firmer, Rebounder Seed Covers or through thin wall stainless steel tubes

**B**  
Components  
Liquid

1. Mount the Keeton Seed Firmer or Rebounder Seed Cover.
2. Route the tube included in the above kit as instructed.
3. Attach the 1/4" tube to the 1/4" QC Y divider fitting.
4. Zip all tubing to the planter and row unit in as many locations as possible.

For thin wall stainless steel tubes, you can push the 1/4" black tubing all the way through the stainless steel tube so fertilizer will run directly from the tubing onto the ground.

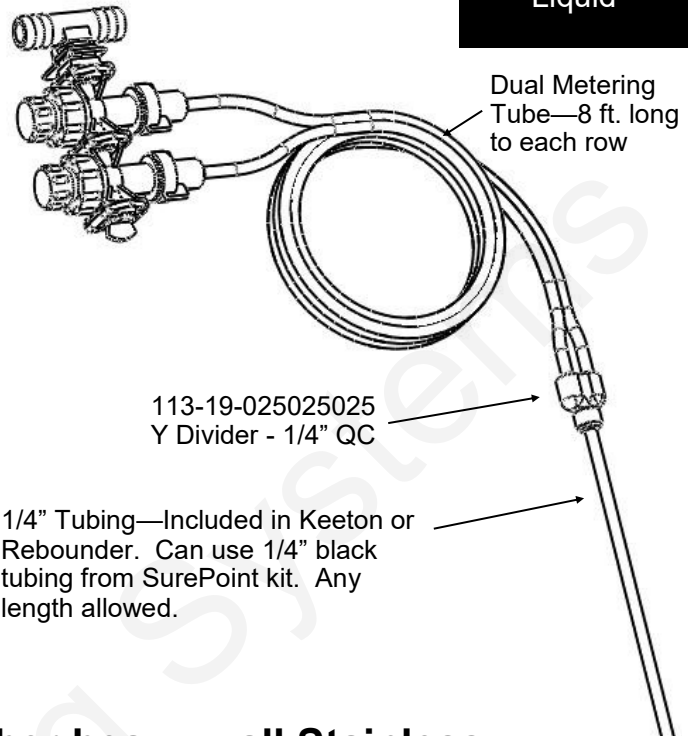

## Connection to Totally Tubular or other heavy wall Stainless Steel Tube Ground Application Devices

When using a 3/8" OD stainless steel tube to apply fertilizer to the ground, there are two options for the delivery tube plumbing. If the tube ID is less than 1/4" (tubing will not fit inside tube) this attachment method must be used. The description following is for Option 1. See bottom right picture for Option 2.

1. Use the 1/4" x 3/8" QC fitting shown. Push the 3/8" end onto the stainless steel tube. (Hint: if the fitting slips off the stainless steel tube, use sandpaper or a file to roughen the end of the tube slightly)
2. Use a short piece of 1/4" black tubing to connect the Y fitting to the reducer fitting on the stainless steel tube.
3. Zip all tubing to the planter and row unit in as many locations as possible.

### Option 1: QC Fitting attaches to SS Tube

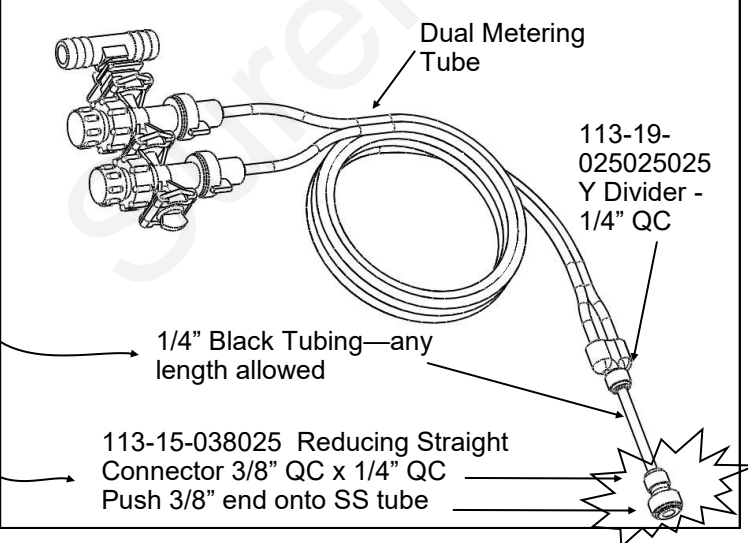

### Option 2: 3/8" Hose attaches to SS Tube

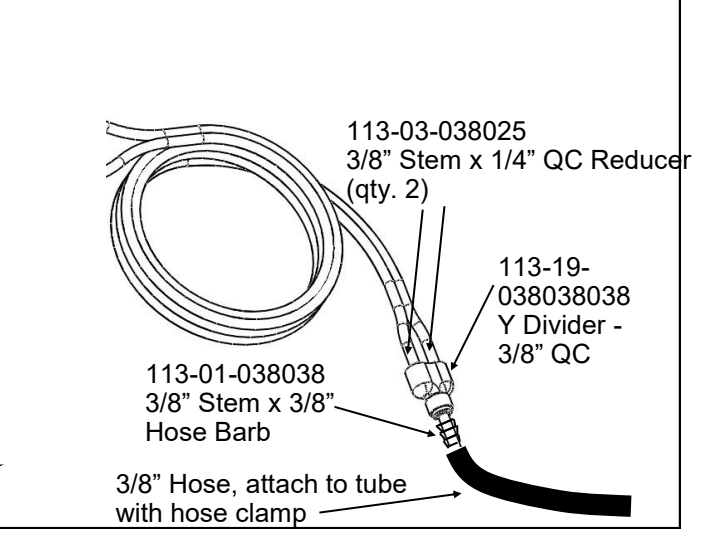

**Electric Pump (Tower) Systems--10-40 PSI (Tubes 8' unless noted)**

Low Viscosity (28-0-0 approx 10.7 lb/gal)				Medium-Low Viscosity (32-0-0 approx 11.0 lb/gal)			
	oz/min	mL/min	gal/min		oz/min	mL/min	gal/min
Tube Color	Flow Range	Flow Range	Flow Range	Tube Color	Flow Range	Flow Range	Flow Range
Gray	3.5-7.4	105-220	0.03 - 0.06	Gray	2.5-5.5	74-163	0.02-0.04
Purple	6-14.4	175-415	0.05 - 0.11	Purple	4.1-11.1	121-328	0.03-0.09
Brown	8-18.2	235-540	0.06 - 0.14	Brown	5.7-14.3	170-425	0.04-0.11
Blue	10-22.6	295-670	0.08 - 0.18	Blue	7.5-18	220-530	0.06-0.14
Green	18-40.2	530-1190	0.14 - 0.31	Green	14-33.2	415-980	0.11-0.26
Tan	25-55	740-1625	0.19 - 0.43	Tan	20-46.4	590-1370	0.16-0.36
Orange	44-93.6	1300-2770	0.34 - 0.73	Orange	36-83	1065-2455	0.28-0.65
Yellow	55-114.4	1625-3380	0.43 - 0.89	Yellow	44-100	1300-2955	0.34-0.78
Black	72-152	2130-4495	0.56 - 1.19	Black	60-129	1775-3815	0.47-1.01
5' Tan	33-73	975-2160	0.26 - 0.57	5' Tan	27-63	800-1865	0.21-0.49
5' Orange	57-121	1685-3580	0.45 - 0.95	5' Orange	49-113	1450-3340	0.38-0.88
5' Yellow	70-145	2070-4290	0.55 - 1.13	5' Yellow	59-134	1745-3965	0.46-1.05
5' Black	95-200	2810-5915	0.74 - 1.56	5' Black	80-172	2365-5085	0.63-1.34

**10-40 PSI 60°F**

Medium Viscosity (Starter, N-P Blend, approx 11.2 lb/gal)				High Viscosity (10-34-0 approx 11.6 lb/gal)			
	oz/min	mL/min	gal/min		oz/min	mL/min	gal/min
Tube Color	Flow Range	Flow Range	Flow Range	Tube Color	Flow Range	Flow Range	Flow Range
Gray	1.5-3.7	45-110	0.01-0.03	Gray			
Purple	2.2-7.8	65-230	0.02-0.06	Purple	1.0-2.8	30-83	0.008-0.02
Brown	3.5-10.4	105-310	0.03-0.08	Brown	1.4-4.2	41-124	0.011-0.03
Blue	5-13.7	150-405	0.04-0.11	Blue	1.8-5.5	53-163	0.014-0.04
Green	9.5-26	280-770	0.07-0.20	Green	2.6-9.4	77-280	0.02-0.07
Tan	14-37.4	415-1105	0.11-0.29	Tan	4-14.8	120-440	0.03-0.12
Orange	27-72	800-2130	0.21-0.56	Orange	9-30	265-885	0.07-0.23
Yellow	33-85	975-2515	0.26-0.66	Yellow	13-42	385-1240	0.10-0.33
Black	48-106	1420-3135	0.38-0.83	Black	18-55	530-1625	0.14-0.43
5' Tan	20-53	590-1565	0.16-0.41	5' Tan	6-22.2	165-655	0.04-0.17
5' Orange	38-101	1125-2985	0.30-0.79	5' Orange	13-43	380-1270	0.10-0.34
5' Yellow	46-118	1360-3490	0.36-0.92	5' Yellow	18-58	540-1715	0.14-0.45
5' Black	67-148	1980-4375	0.52-1.16	5' Black	25-76	740-2250	0.20-0.59

**10-40 PSI 60°F--For 10-34-0 select a tube with additional capacity for cold weather.**

Water (8.34 lb/gal)			
	oz/min	mL/min	gal/min
Tube Color	Flow Range	Flow Range	Flow Range
White	2.5-5.5	75-165	0.02-0.04
Gray	5.8-11.6	170-340	0.045-0.09
Purple	10-20	295-590	0.08-0.16
Brown	12.5-25	370-740	0.10-0.20
Blue	17.5-35	520-1040	0.14-0.28
Green	26-52	770-1540	0.20-0.40
Tan	34-68	1005-2010	0.27-0.54
Orange	60-120	1775-3550	0.47-0.94
Yellow	75-150	2220-44400	0.59-1.18

**These charts are typical flow rates from 10 to 40 PSI.**

**The capacity of electric pumps declines as the pressure increases. If total pump output is low enough, they can operate at 50 psi or more.**

**These charts are designed for typical N-P fertilizers. Suspension, granular, and/or clay/based products may not follow these charts.**

**These charts are for product at 60° F. Products will be thicker and pressure will be higher at lower temperatures (esp 10-34-0). *MAW***

# Ag Leader Liquid Product Control Module

D

Wiring & Elec.

The Liquid Product Control Module is the legacy Ag Leader control module. It is still a very good control module.

Ag Leader also has an ISO Liquid Control module. The following pages show how to connect to both of these.

SurePoint Fertilizer Systems begin at the Ag Leader Liquid Product Control Module. The picture below shows this control module. You will need to purchase this module from your Ag Leader dealer.

The rate controller has four harness connections. The function of each connection is labeled in the picture below and on the next page. The following pages show system diagrams for single section, 2-6 section and 7-12 (maximum of 10 sections of LPCM) section configurations. Detailed harness drawings follow for information and troubleshooting.

Instructions for setting up the Ag Leader in cab display are in Section F. Detailed screen shots of the display are included showing exactly what settings are required and recommended for SurePoint Fertilizer Systems.

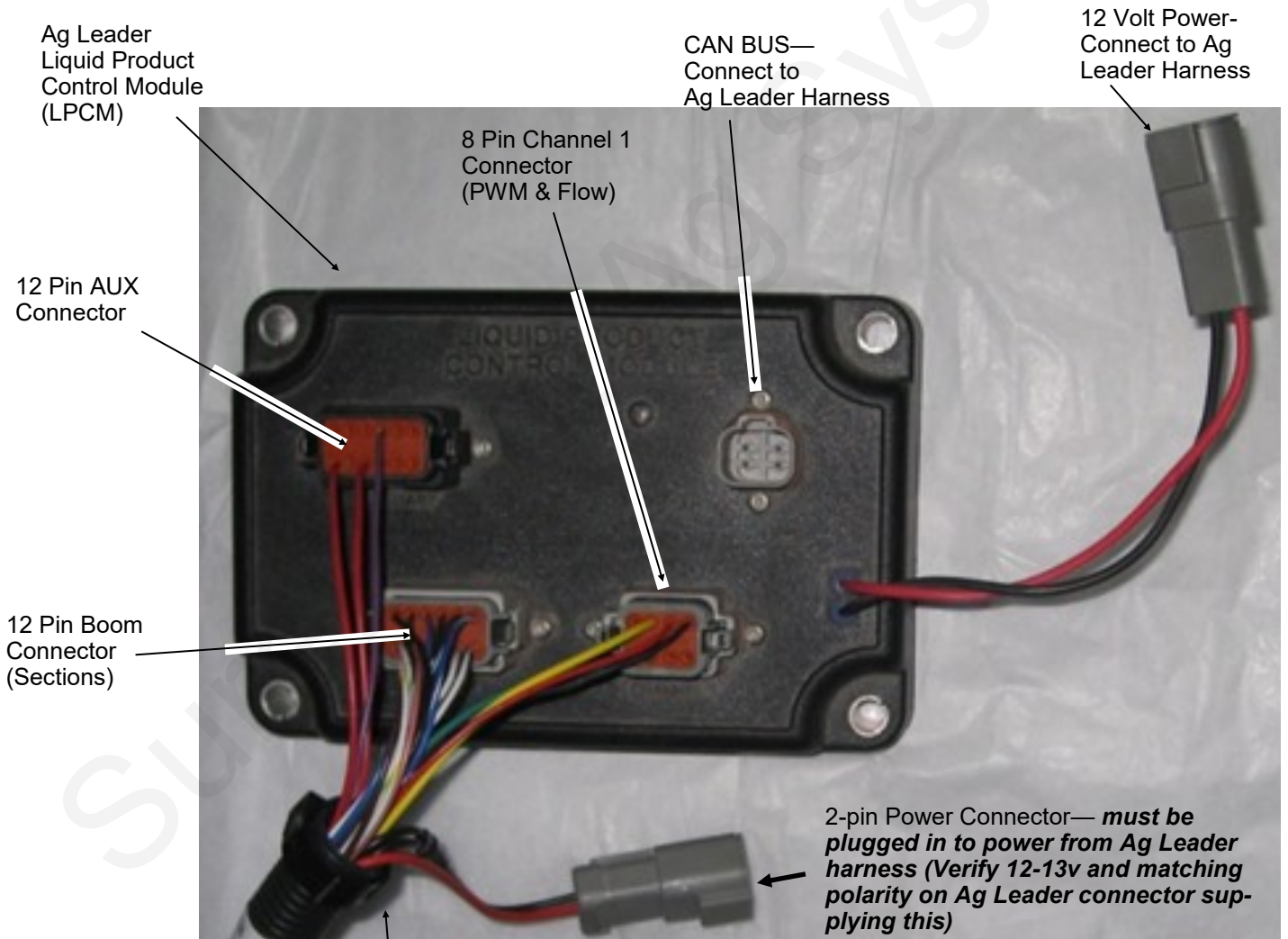

SurePoint adapter for Ag Leader LPCM to pump and sections.  
SurePoint PN **201-215468Y\*** or **213-01-3768Y\***.

**Implement Lift Switch Jumper (included) MUST be installed if no implement lift switch installed**

# Ag Leader Liquid Product Control Module

**D**  
Wiring & Elec.

This chart shows you the output functions by pin location on the Ag Leader Liquid Product Control Module. Use this information to verify if the Ag Leader system is providing the correct output. If the module is not providing the correct output, contact your Ag Leader dealer to repair the problem. Also review any applicable settings on the display to verify the system is properly set up.

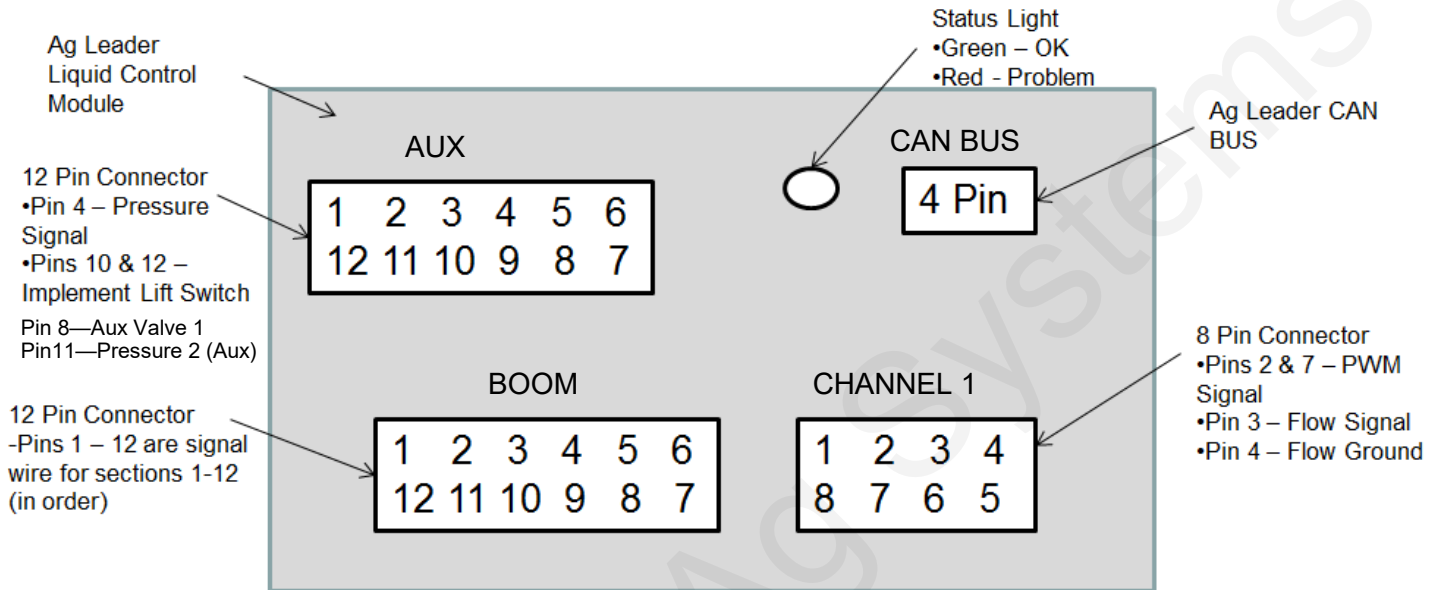

## Common Troubleshooting:

**PWM Signal to Pump:** Pin 2 to 7 should have 0-12 volts to turn pump on. Use manual mode to increase signal. Should get up to 12 volts after holding increase button.

**Flow meter Tap Test:** Pins 4 and 3 are Flow Ground and Signal. If no flow is registering on the display, you can tap between these two pins with a short wire. This produces a pulse. The display should indicate a flow when this is done rapidly.

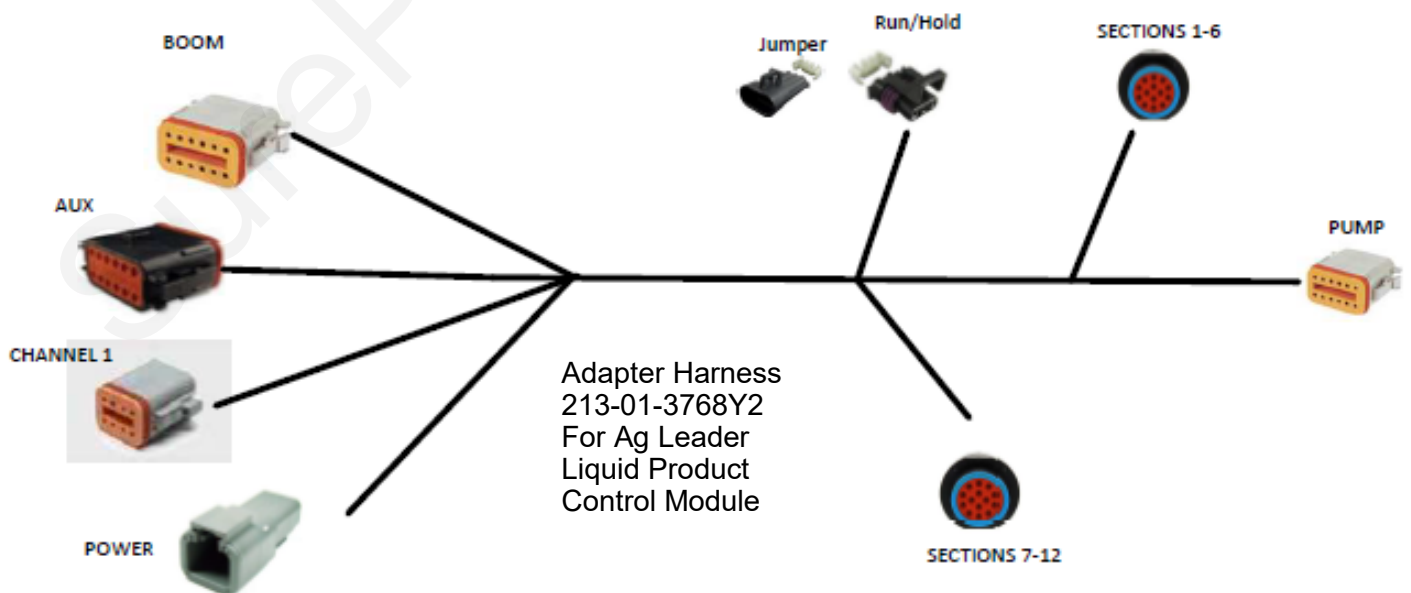

# Connecting Liquid Product Control Module

**D**  
Wiring & Elec.

Plug in Adapter Har-  
ness  
213-01-3768Y\_  
Or previous Sure Fire  
systems used  
201-215468Y\_

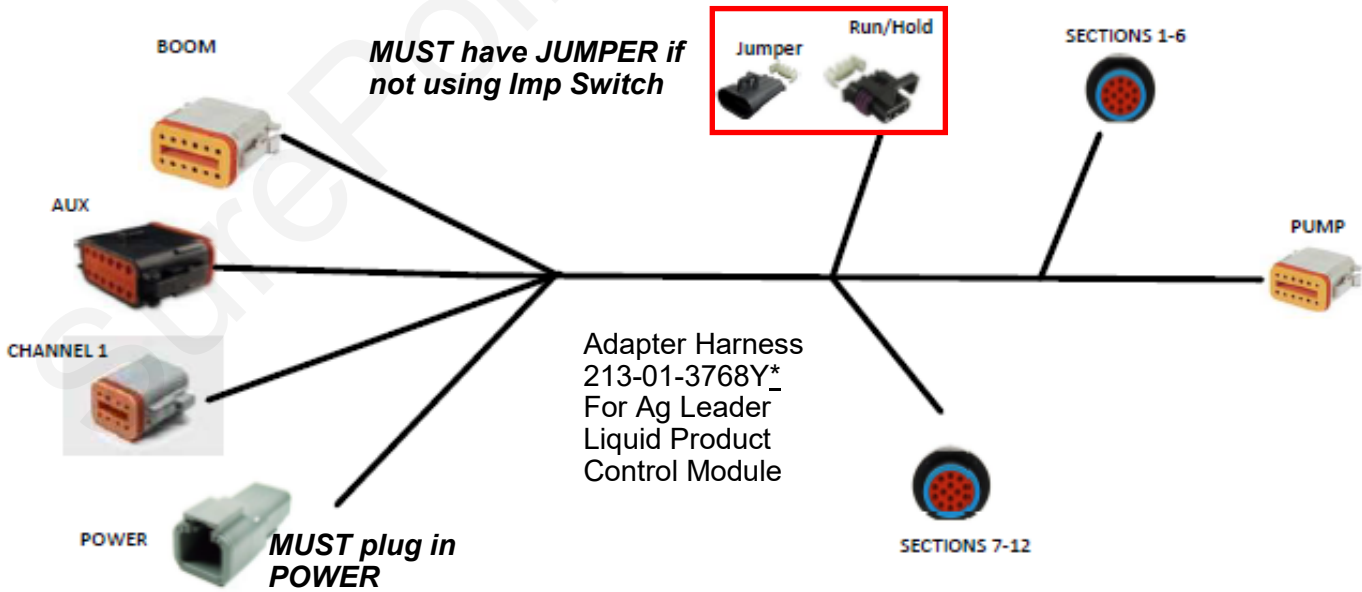
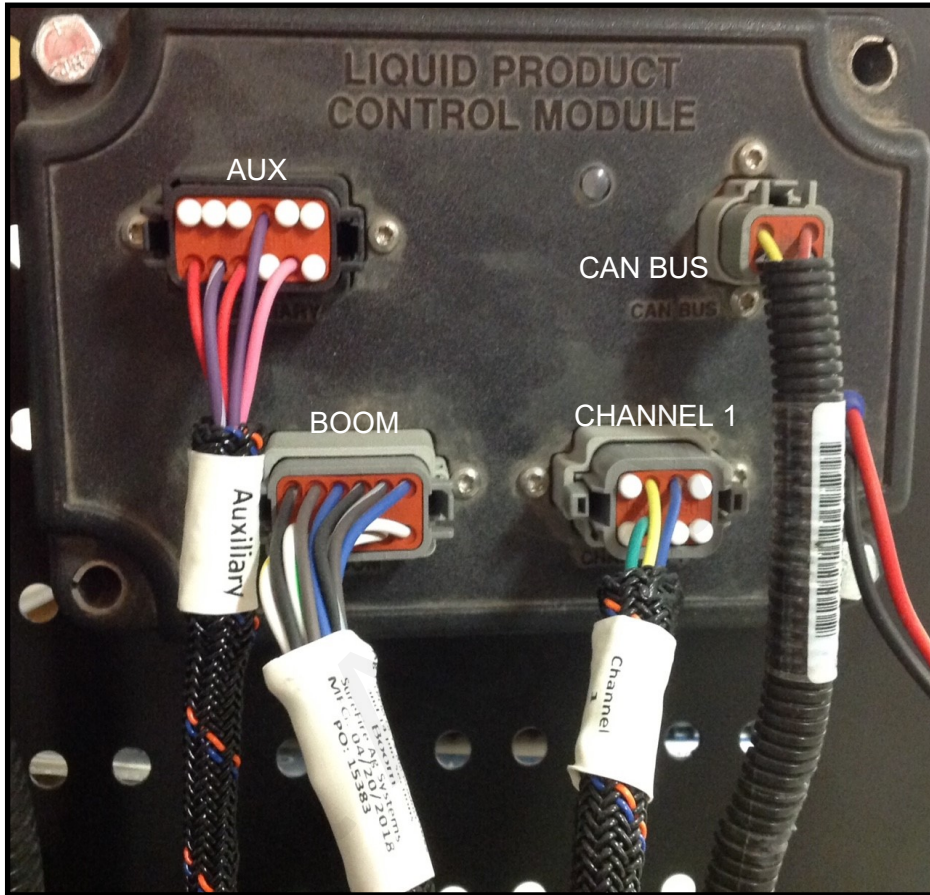

# Auxiliary Input Module

Connects to Ag Leader Display with Ag Leader harnessing

D

Wiring & Elec.

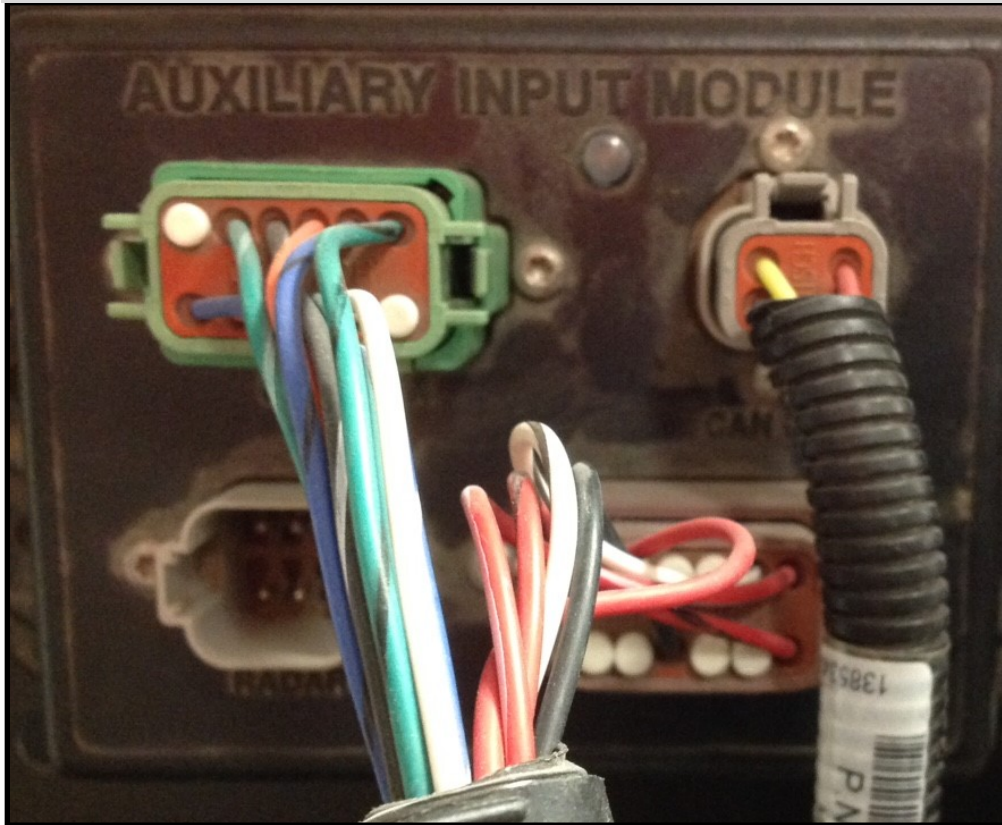

# Ag Leader ISO Liquid Rate and Liquid Swath Control

**D**  
Wiring & Elec.



Ag Leader harnesses

4002597-xxx  
ISOBUS Breakout

4002767 High Current Power

4002567 Local CAN Breakout

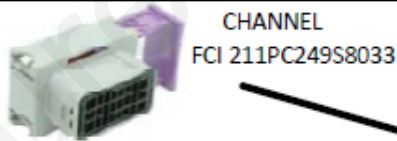
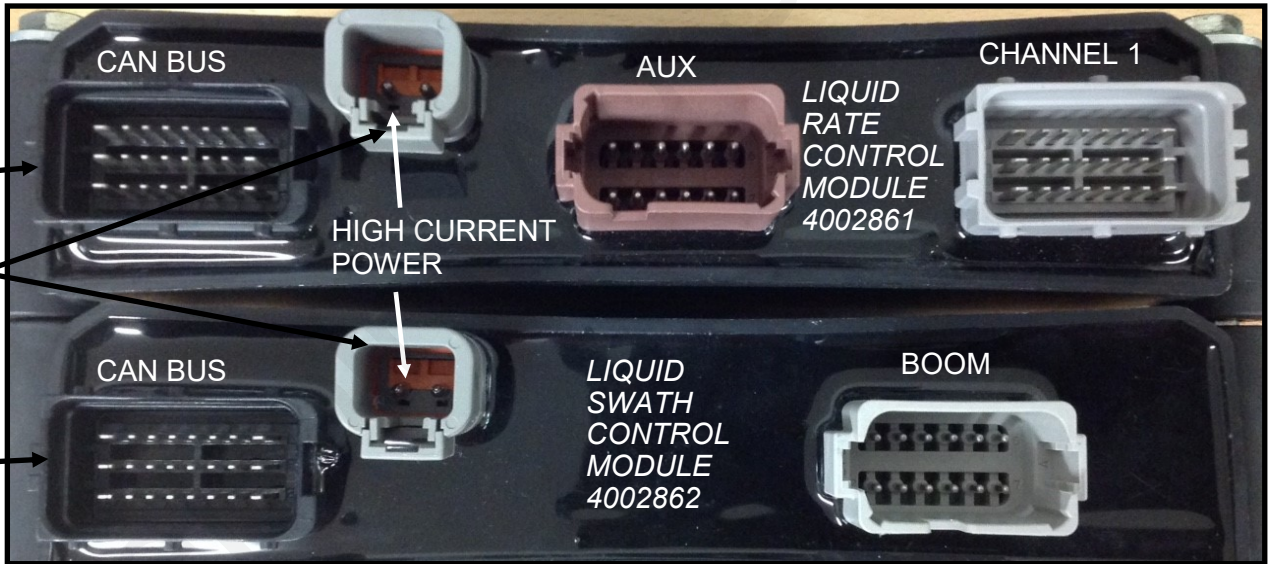

Use SurePoint Adapter Harness 213-01-3620Y\*  
For Ag Leader  
ISO Liquid Rate and Swath Modules

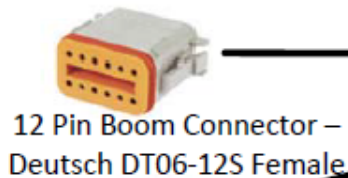

12 Pin Boom Connector –  
Deutsch DT06-12S Female

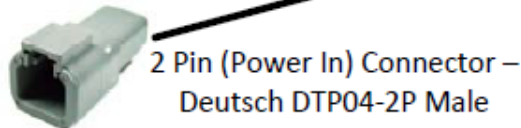

2 Pin (Power In) Connector –  
Deutsch DTP04-2P Male

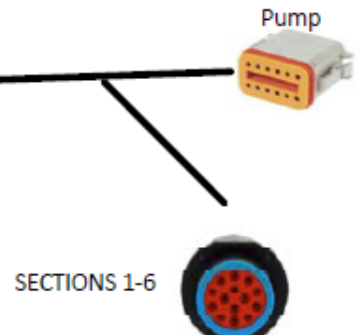

# Ag Leader L2 Liquid Rate and L2 Liquid Swath Control

**D**  
Wiring & Elec.

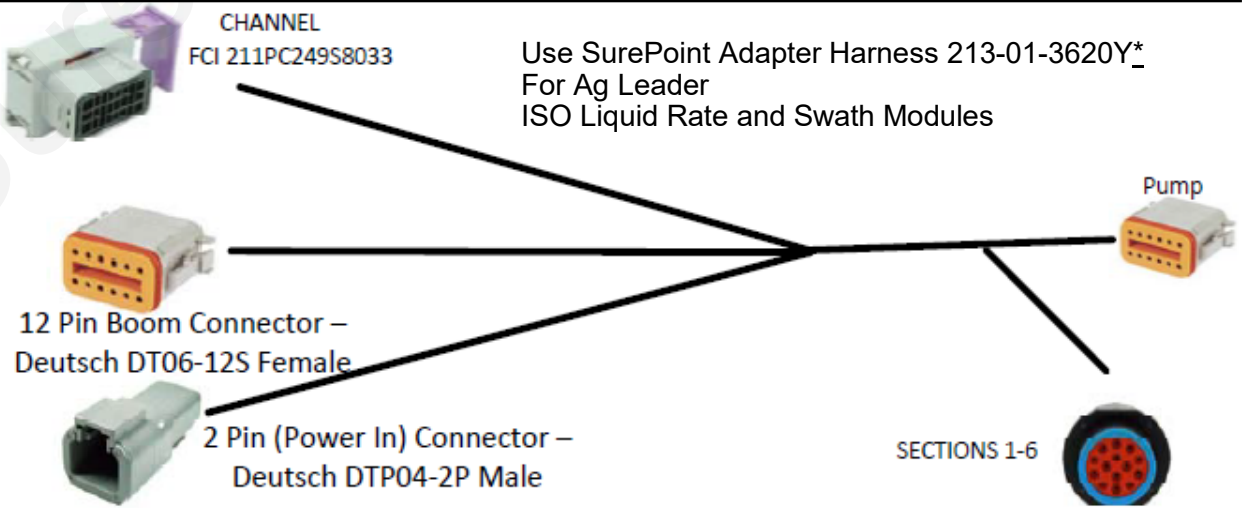
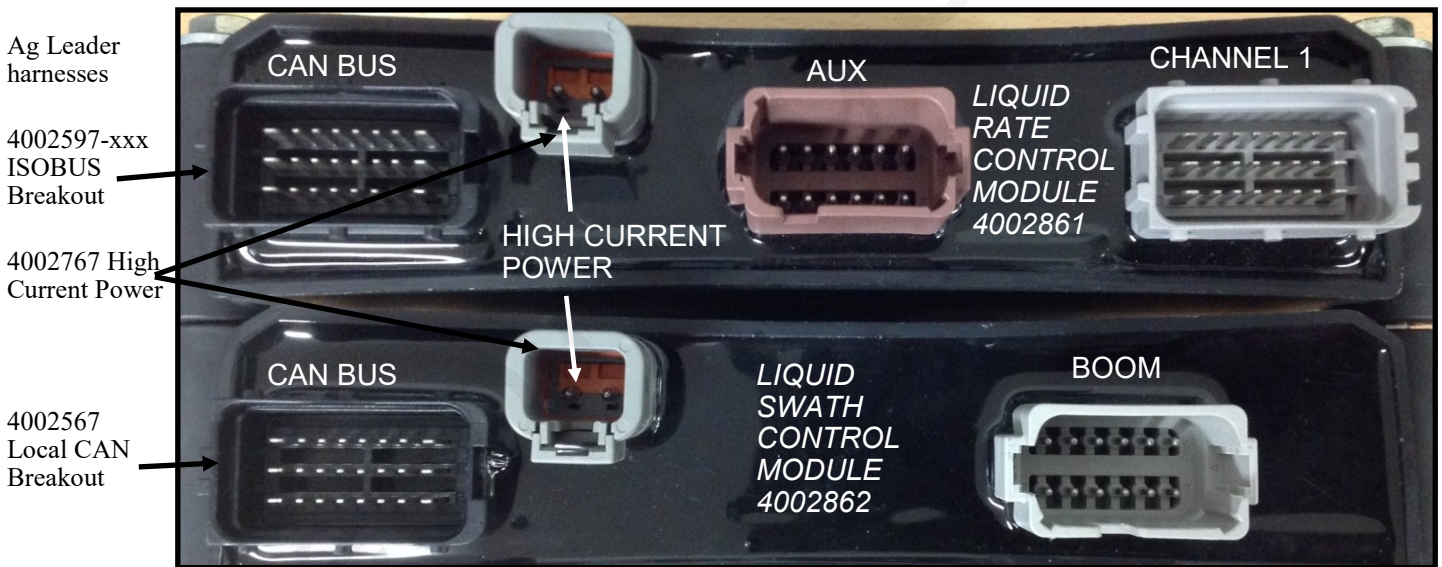
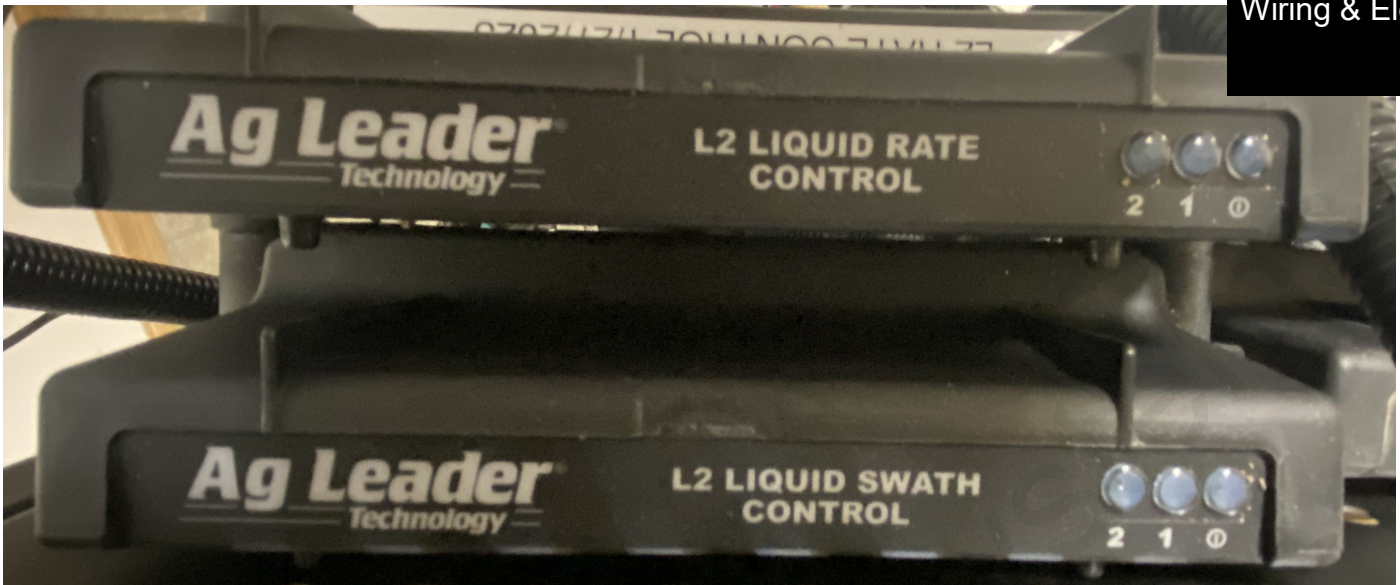

# Ag Leader ISO Aux Input and Implement Switch Module

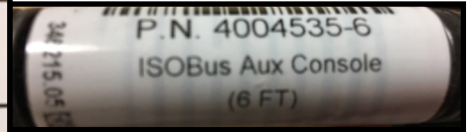

Master  
 Boom Sections (1-7)  
 Rate 1, Rate 2,  
 Manual  
 Target Increment,  
 Increase/Decrease

Items needed for Implement Switch (Optional from Ag Leader)

CAN Implement Switch Module	4002911
CAN Implement Switch Cable	4002658

Some kind of Implement Switch (available from

# Ag Leader Gen 2 to Gen 1 Liquid Adapter

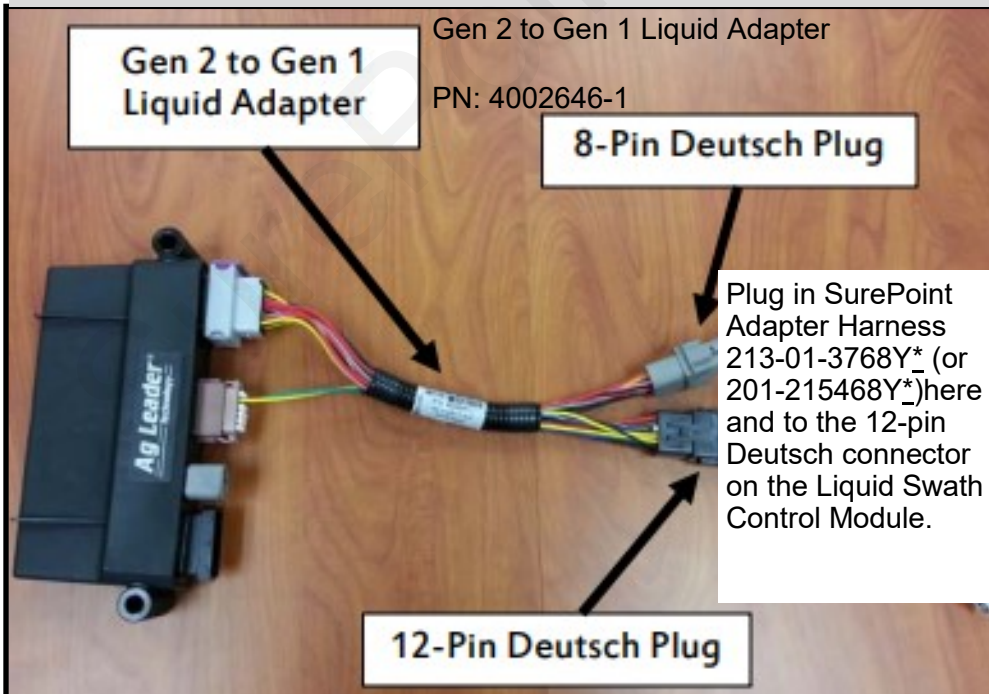

If the ISO Liquid Module is replacing an Ag Leader Liquid Product Control Module, start with the Gen 2 to Gen 1 Adapter and then use the same harnessing that was used before.

This adapter can also be used on a new setup if you will be using the Gen 1 harnessing from SurePoint.

The adapter is not necessary if using SurePoint 213-01-3620Y\* adapter harness.

# Ag Leader SC110 Switch Console for L2 Control



# Tower & Ag Leader Control Layout

Control: PWM EPD

Sections: 3



Both Connect to 12 Volt Power Connection on Ag Leader Harness

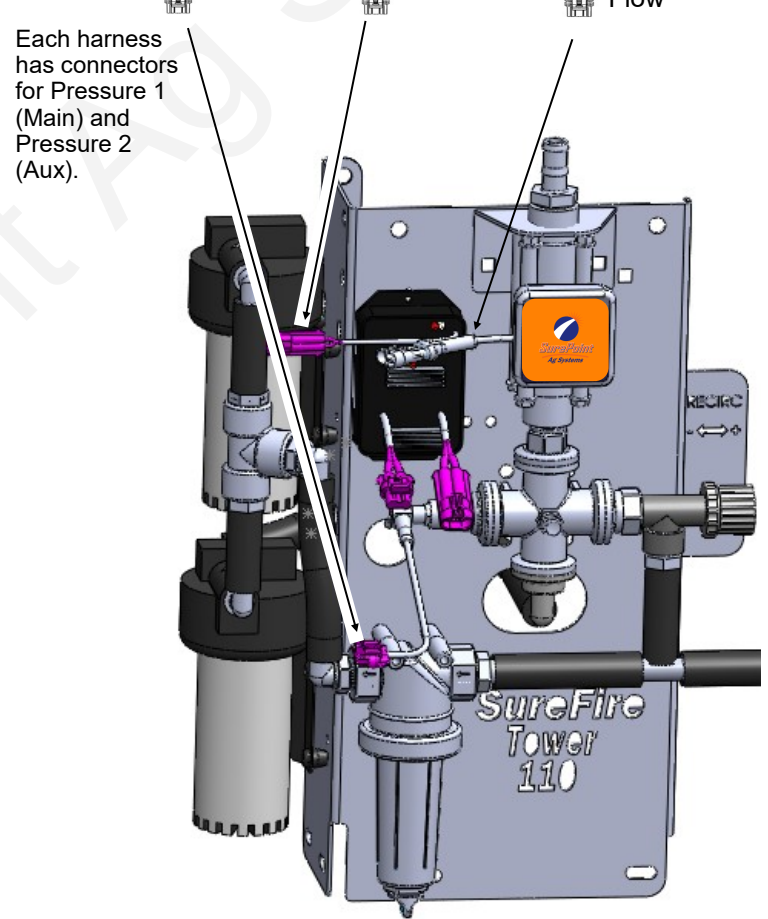
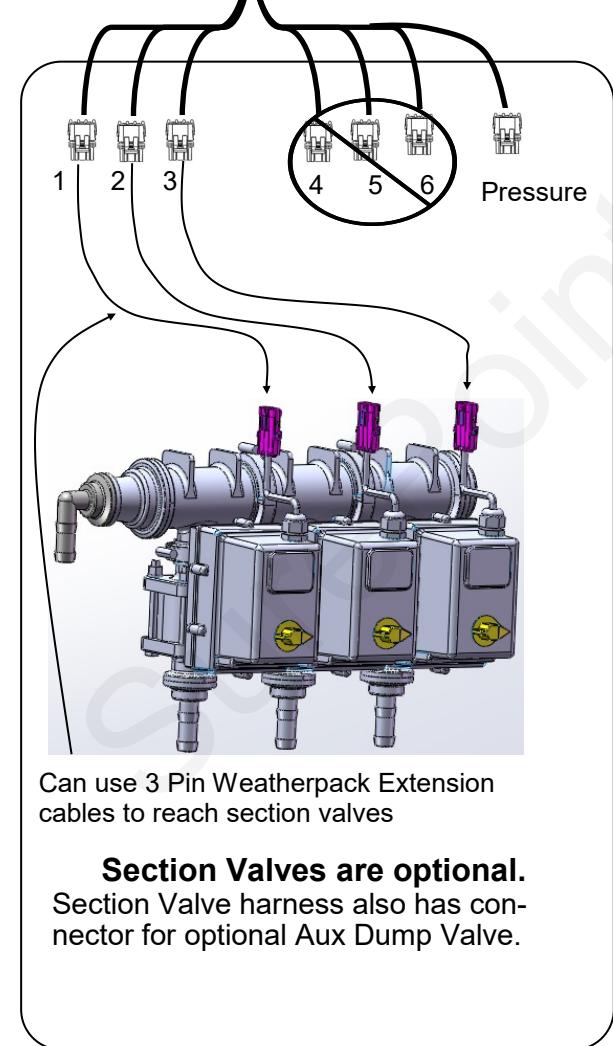
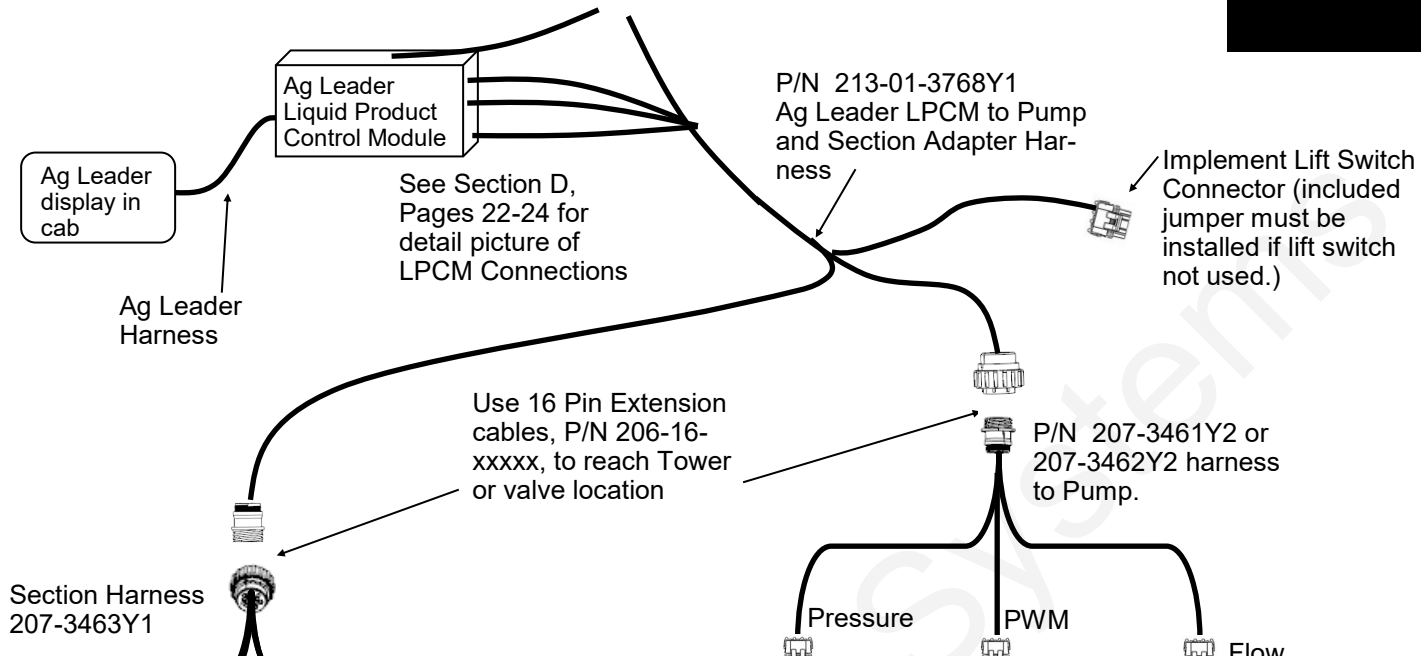

# 40 Amp PWM EPD

(Pulse Width Modulated Electric Pump Driver)

Item Number: 205-19024 with Anderson connectors  
(replaces 205-18385 with 480 MP connectors)



The Electric Pump Driver powers 1 or 2 electric pumps by providing a pulse width modulated signal to control pump speed. It needs to have a power connection and wiring capable of carrying up to 40 amps of current. **It must be connected directly to the tractor battery.** SurePoint recommends 8 gauge wire (or heavier) if extending harnesses in the field.

## 205-19024

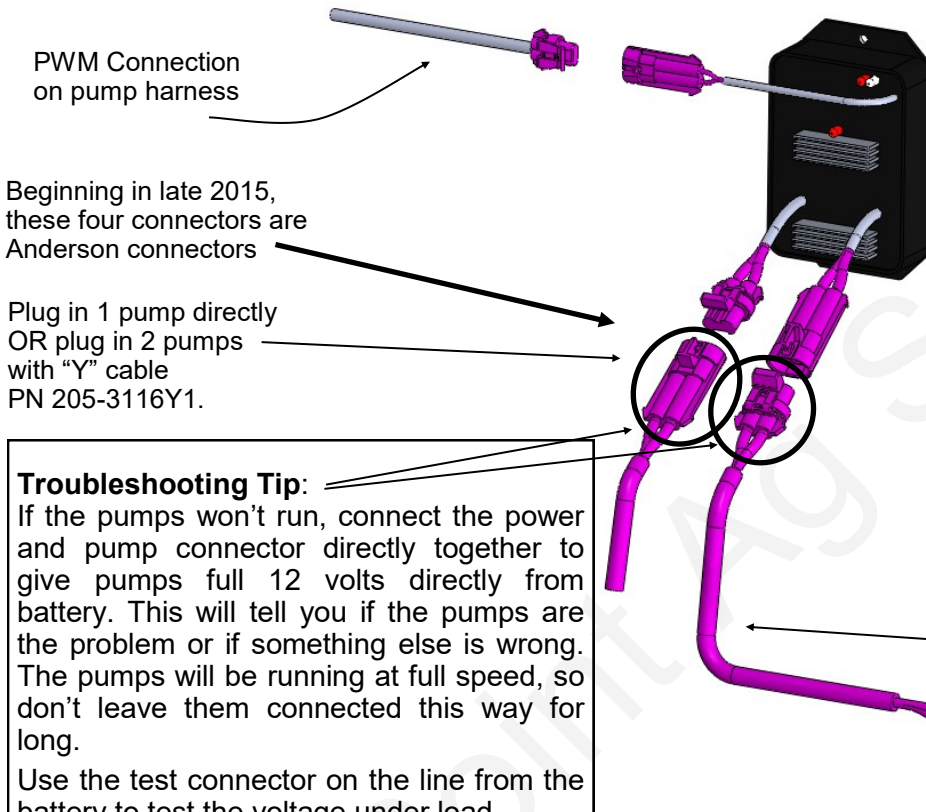
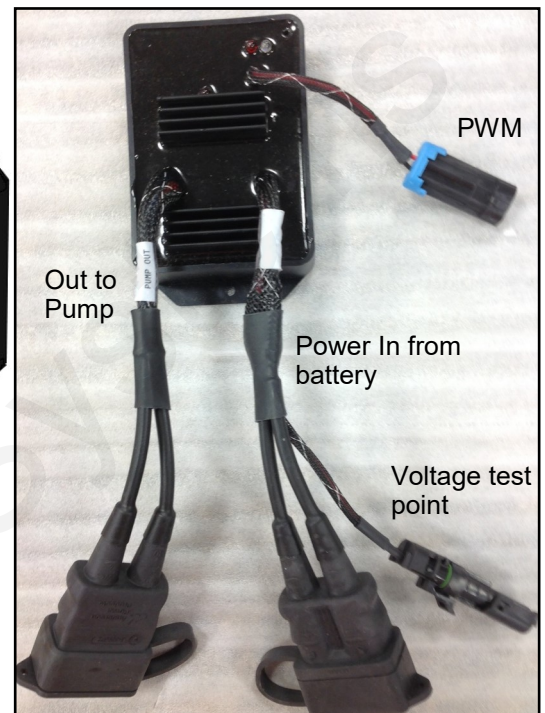

### Troubleshooting Tip:

If the pumps won't run, connect the power and pump connector directly together to give pumps full 12 volts directly from battery. This will tell you if the pumps are the problem or if something else is wrong. The pumps will be running at full speed, so don't leave them connected this way for long.

Use the test connector on the line from the battery to test the voltage under load.

**The most common issue with the EPD will be a low voltage condition delivered to the EPD from the battery. Voltage drop occurs anytime current is moved through a wire. A low-voltage (12 v) system with long runs (60-80 feet) may have unacceptable voltage drops if any part of the system is weak or the load is high. This could be bad (corroded, weak, loose or burnt) connectors (at the battery, at the hitch, and at the EPD), too small of wire used (smaller wire equals more voltage drop), low source voltage, and heavy load. Any or all of these may contribute to a low voltage condition under load that may shut down the processor in the EPD module. This will be indicated by 4 quick flashes of the red light, followed by a short pause. Unplug the power-in connector to reset the EPD.**

EPD Power Harness PN 205-3118Y1 (20 feet) - **connect to tractor battery.** This is 6 AWG wire.

40 Amp in-line fuse

Use EPD **Power Harness Extensions** as needed (These have Anderson Connectors)

Part Number	Description	Wire Size
206-02-3120Y1	1' Extension	10 gauge
206-02-3121Y1	5' Extension	10 gauge
206-02-3122Y1	10' Extension	8 gauge
206-02-3123Y1	20' Extension	8 gauge
206-02-3124Y1	30' Extension	30' and longer—6 AWG
206-02-3125Y1	40' Extension	
206-02-3126Y1	50' Extension	
206-02-3127Y1	60' Extension	
206-02-3128Y1	2' Anderson Ext w/ Power Switch-8 AWG	

SurePoint recommends a single long extension harness as multiple connectors will reduce voltage, increase current and hurt performance of your electric pump system.

# Ag Leader Harness Wiring Diagrams



Your Ag Leader system may have one of the following sets of harnesses. The first set is being introduced for the 2018 season. The second set is the legacy set that has been used for several years.

## ***New Ag Leader harnesses for the 2018 season for Liquid Product Control Module:***

### **Adapter Harness**

213-01-3768Y2 Ag Leader LPCM Adapter harness with 12-pin Product and 14-pin Section connectors

### **Pump Harness**

207-3461Y2 12-pin Final Cable for Tower with 1 or 2 Section Valves (PWM, Flow, Pressure, Sections 1 and 2)

Or  
207-3462Y2 12-pin Final Cable for SurePoint Liquid System (PWM, Flow, Pressure)

### **Section Harness (if needed)**

207-3463Y1 14-pin 6-section Final Cable

## ***Ag Leader Legacy Harnesses for Liquid Product Control Module***

### **Adapter Harness**

201-215468Y4 Ag Leader Liquid Module to twin 16-pin AMP connectors

### **Pump Harness**

207-215223Y2 PWM Pump Cable

### **Section Harness**

207-215466Y2 16-pin 6-Section Harness

## ***Harnesses for Ag Leader ISO Liquid Rate Control Module***

### **Adapter Harness**

213-01-3620Y1 Ag Leader Liquid ISO Module Adapter Harness with 6 sections

### **Pump Harness**

207-3461Y2 12-pin Final Cable for Tower with 1 or 2 Section Valves (PWM, Flow, Pressure, Sections 1 and 2)

Or  
207-3462Y2 12-pin Final Cable for SurePoint Liquid System (PWM, Flow, Pressure)

### **Section Harness (if needed)**

207-3463Y1 14-pin 6-section Final Cable

# 213-01-3768Y2

## Ag Leader Adapter Cable LPCM to 12-pin Product and 14-pin Sections

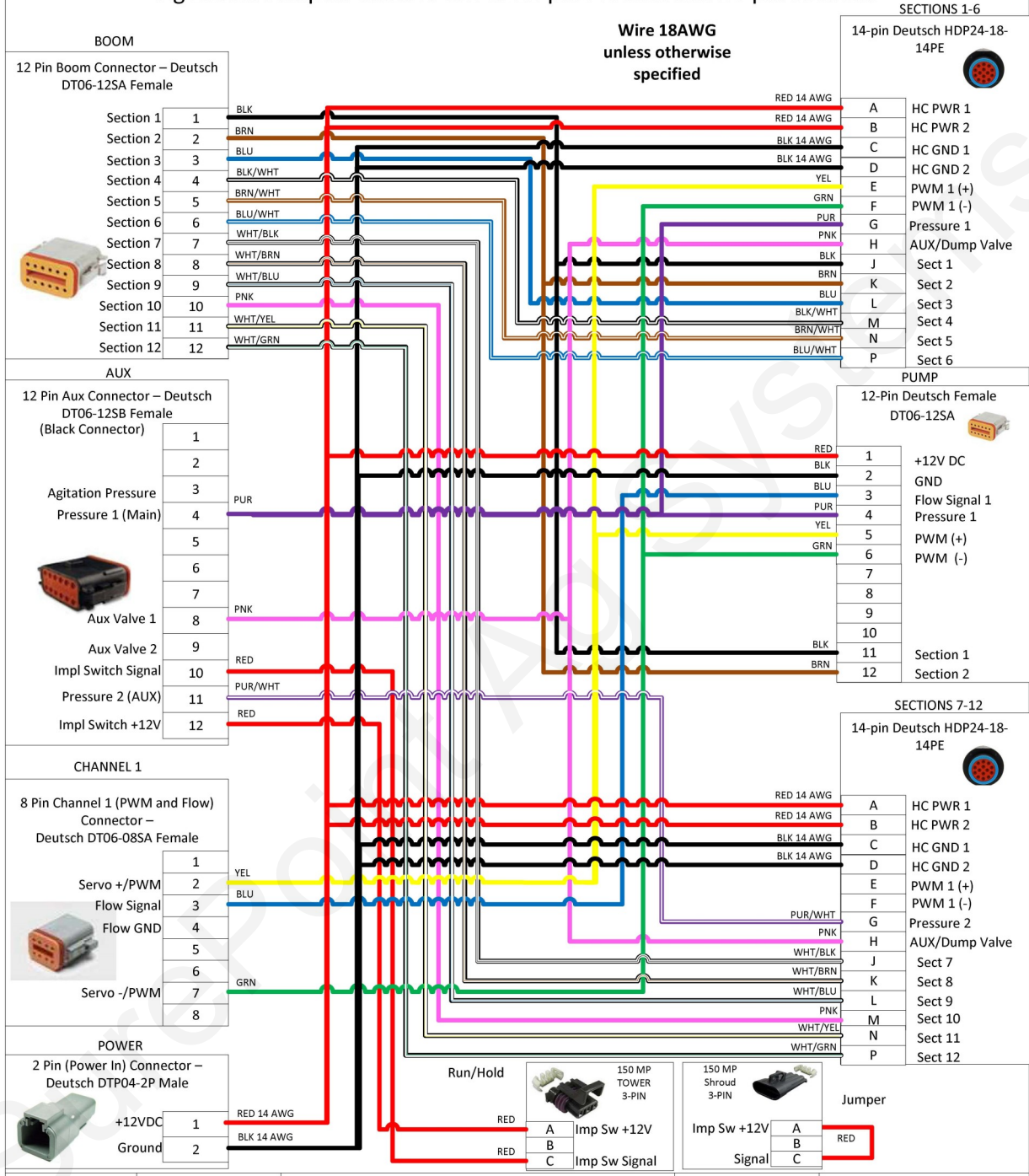

207-3461Y2

Final Cable for Tower With 1-2 Section Valves (pwm, flow, pres., sec 1, sec 2)

Wire 18AWG  
unless otherwise  
specified

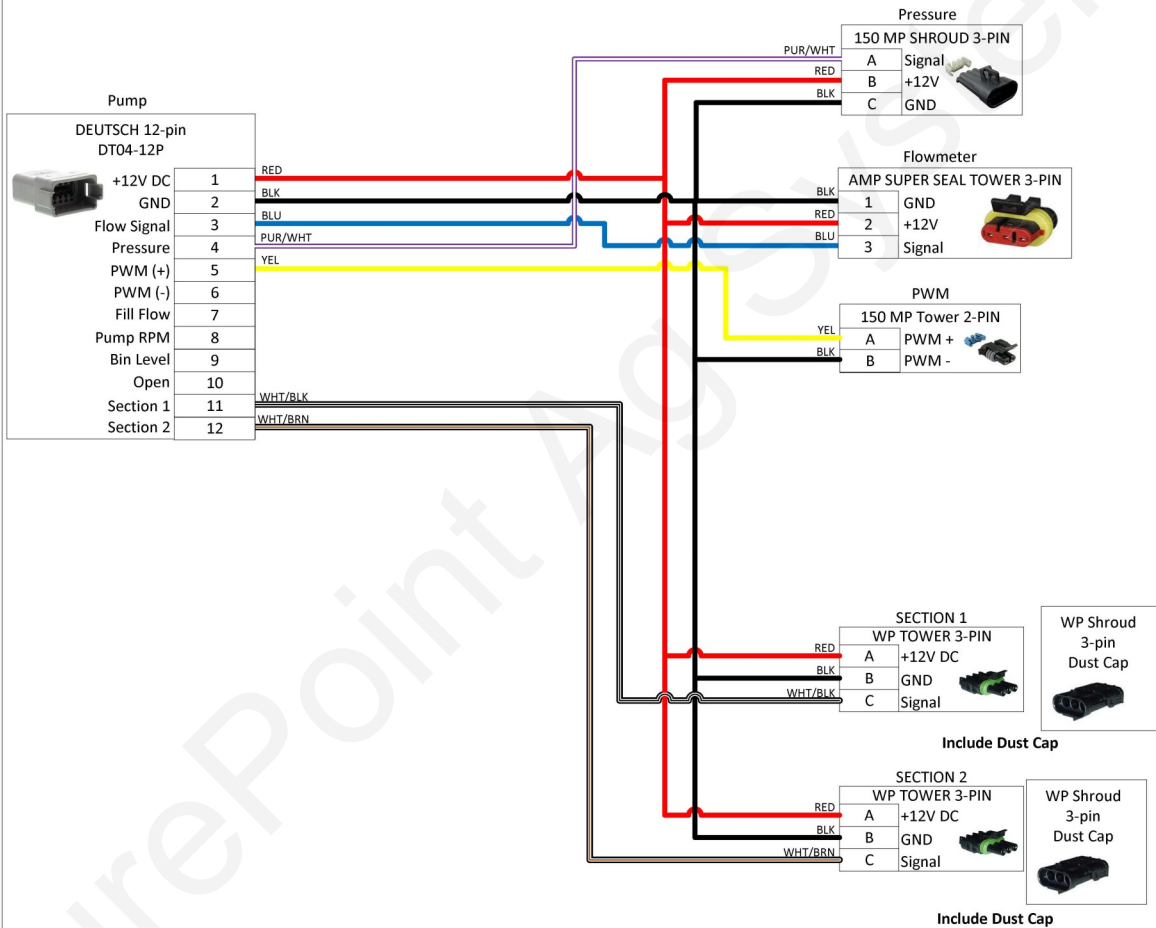

207-3462Y2

Final Cable for SurePoint Liquid Pump System (pwm, flow, pres., pump rpm)

Wire 18AWG  
unless otherwise  
specified

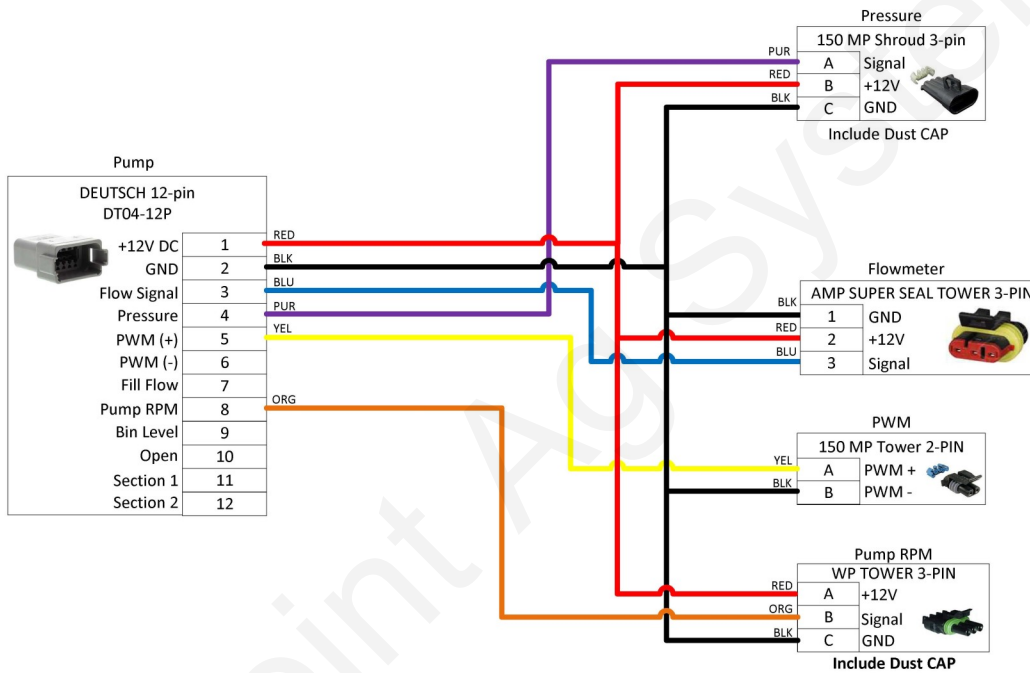

207-3463Y1

14-Pin 6 Section Final Cable (6 sections, flow return, pressure)

Wire 18AWG  
unless otherwise  
specified

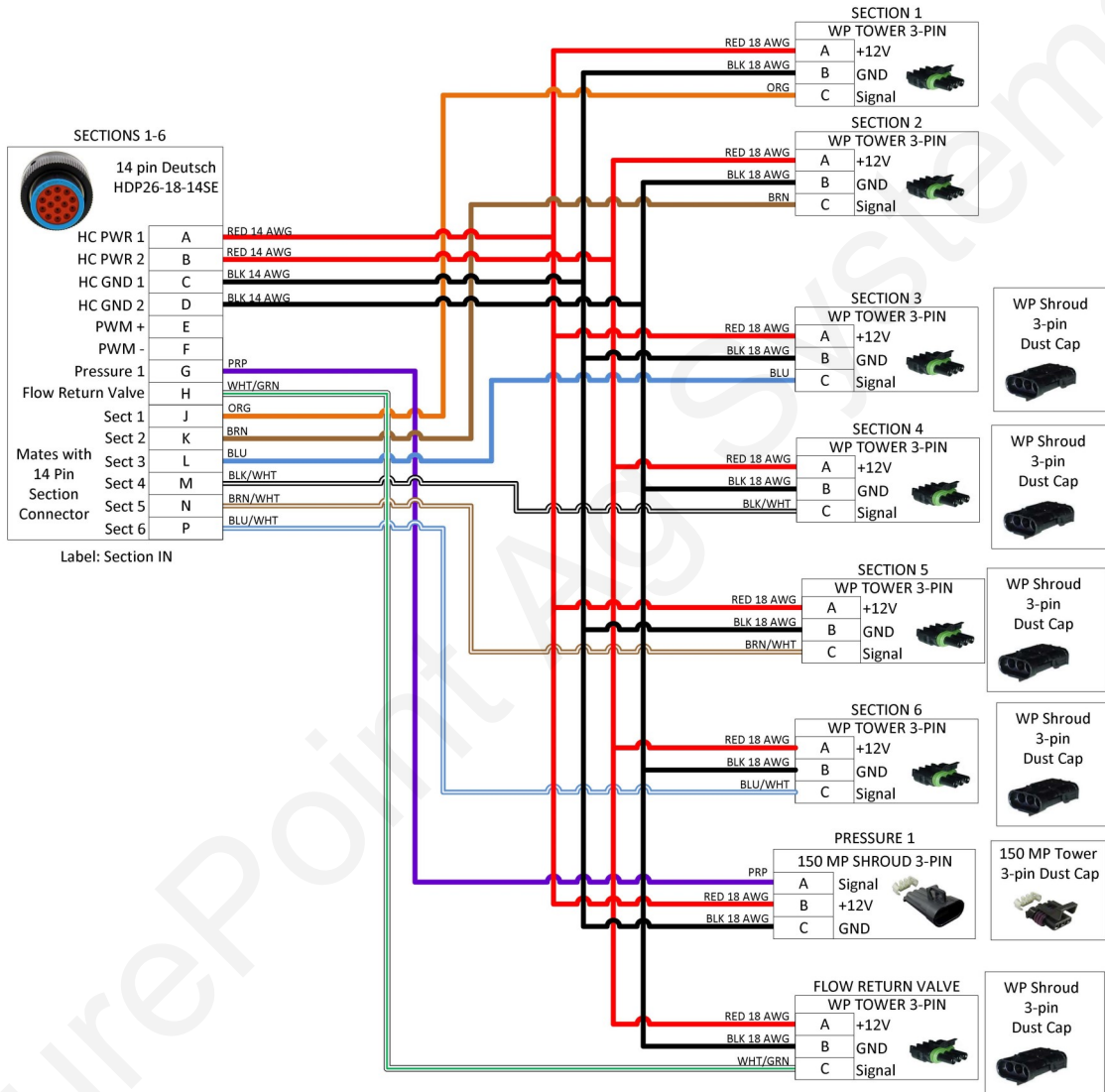

213-01-3620Y1

Ag Leader Liquid ISO Module Adapter Harness (PR 1, Sec 1-6)

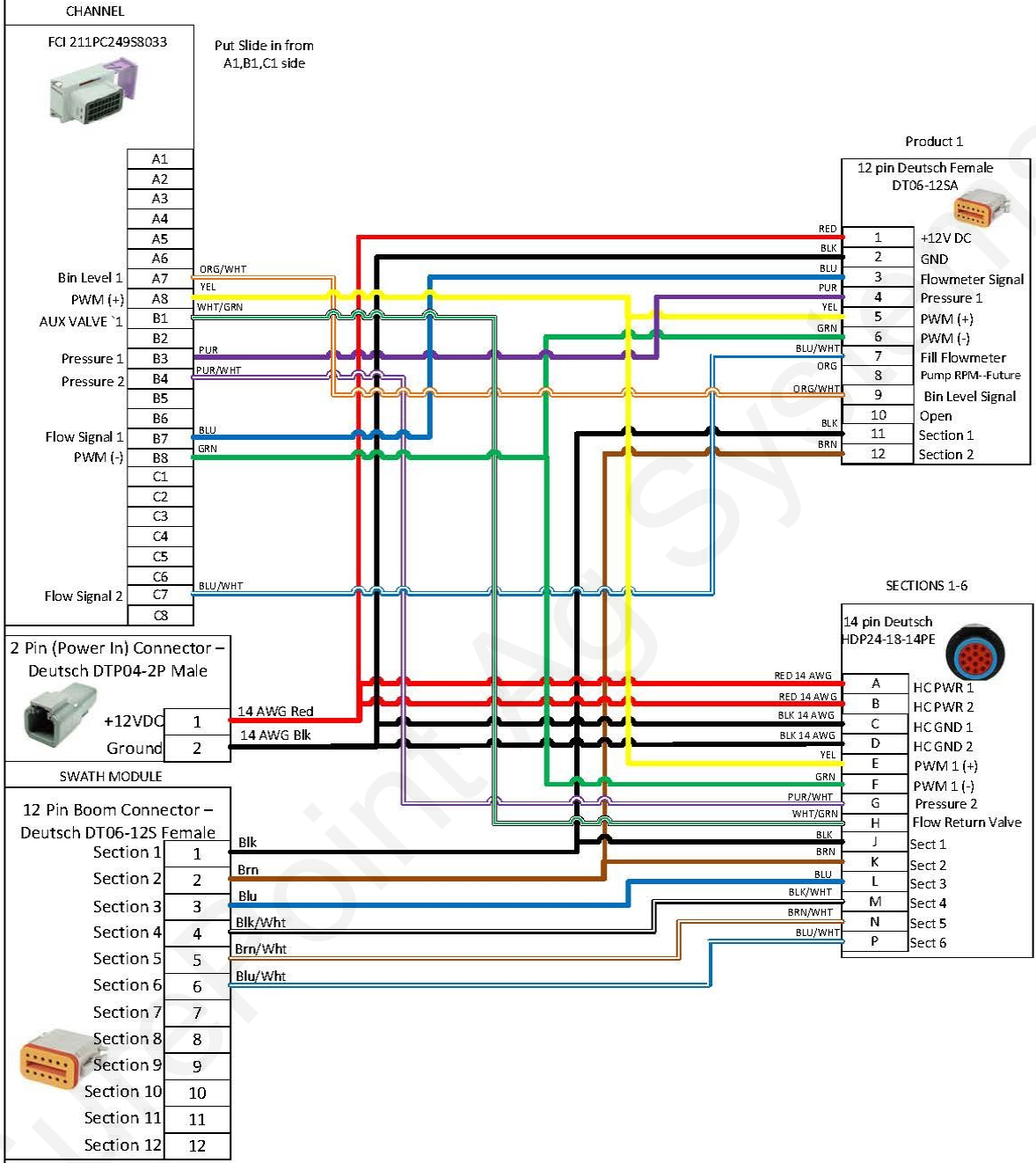

# Floating Ball Flow Indicators

Flow Indicators are extremely flexible and can be mounted in hundreds of different configurations on various types of liquid application equipment. This page is to give you some ideas and let you customize the installation for what works best on your equipment.

## E Installation Overview

### 16-Row

#### Split 6 - 4 - 6

This configuration works well on a 16-row front fold planter. Each flow indicator manifold is shown fed by a cross in a single section installation. Each manifold could be fed by a section valve if desired.

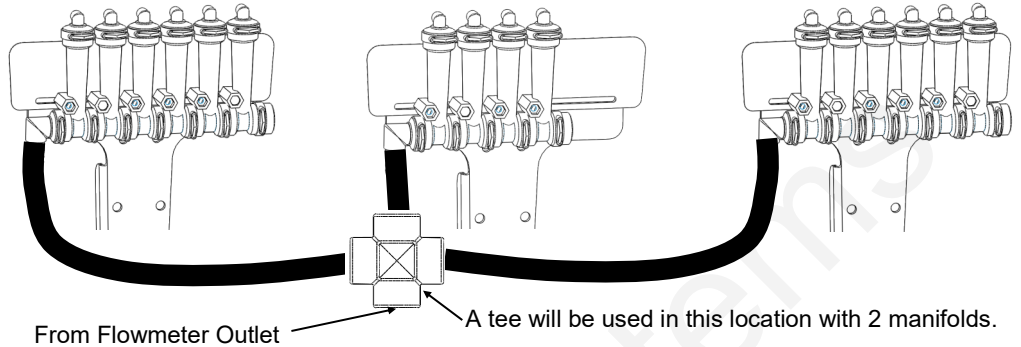

### 12-Row

#### Split 3 - 3 - 3 - 3

Shown here is a 12-row with four 3 row sections controlled by four section valves. Note each 6 row T-Bracket can hold two separate 3-row manifolds.

A 4-section 24-row could be similar with four 6-row manifolds on two large T-Brackets.

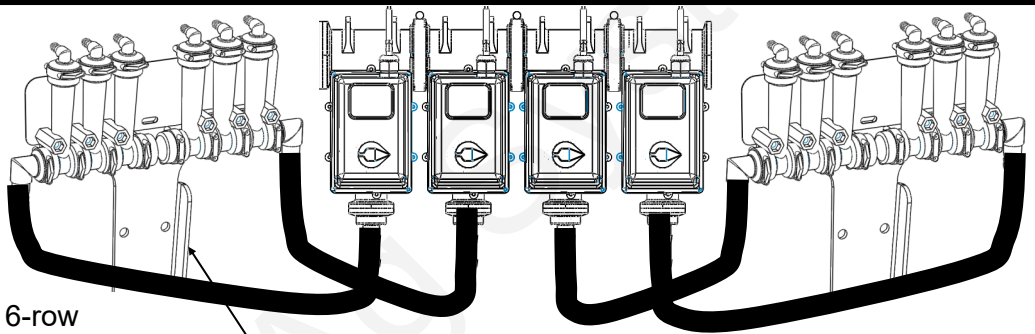

### 12-Row Dual Product

#### Product 1 Split 4 - 4 - 4 / Product 2 Split 4 - 4 - 4

In this case each manifold would be fed by a section valve. There would be 6 total section valves (3 sections X 2 products). Most often one set (top) of flow indicators would be Full Flow for high rate fertilizer and 2nd set (bottom) would be Low Flow for starter.

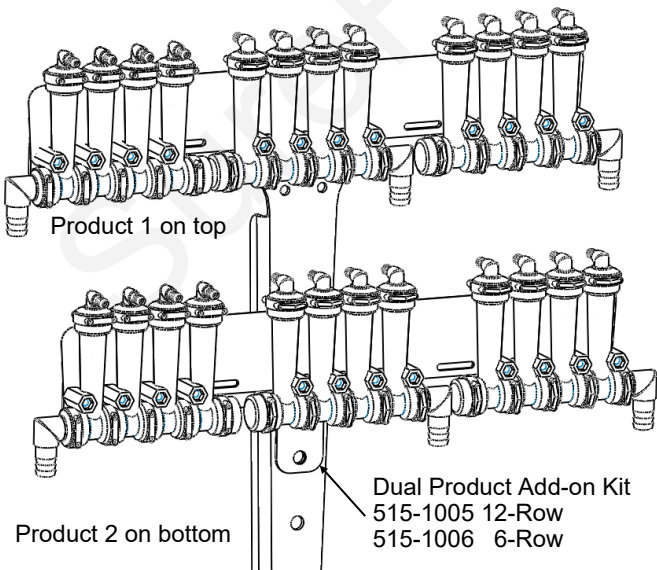

### General Plumbing Guidelines

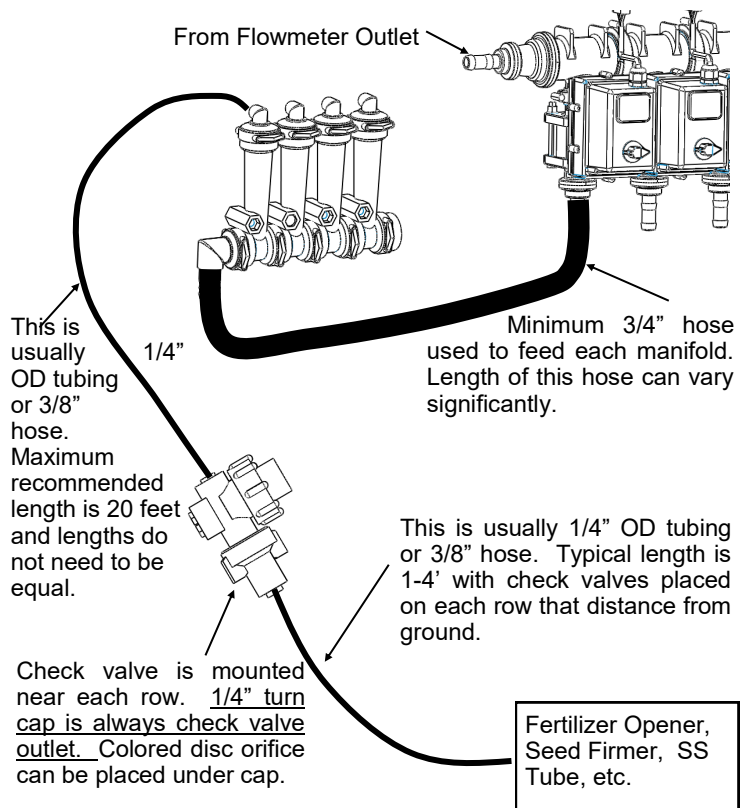

# Tower 110 & 200 Mounting Options

# E

Installation  
Overview

## Tower Basic Mounting Bracket

Item Number:

**511-1007 (8x16 hitch)**

**511-1008 (8x12 hitch)**

This kit includes a bracket to mount to the top side of a bar or hitch and mount the tower directly over that bar. It is often used on front fold planter hitches. U-bolts to mount to two common hitch sizes are included in the kits as labeled above.

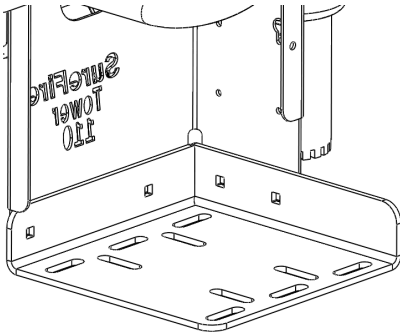

## Tower Offset Mounting Bracket

Item Number **511-1010**

The Tower is available as a stand alone item. This kit includes a bracket to mount to the top side of a bar and hold the Tower. U-bolts are NOT INCLUDED. They must be ordered separately based on mounting bar size. Multiple slots allow the Tower to be mounted away from or directly over the bar.

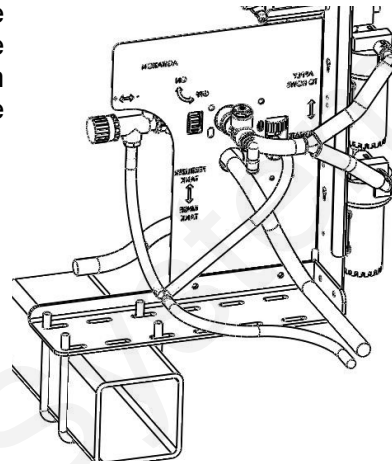

## Tractor Front Mount Elliptical Cradle Tower Mounting Bracket

Item Number **511-1009**

Mounts a Tower directly to the front of tractor front mount 200 & 300 gallon elliptical tank cradles. This bracket will mount the back of the tower just over 4 1/2" forward of the flat bracket mounting face. When using a tractor mounted tank, SurePoint recommends mounting the Tower near the tank, not back on the implement. Electric pumps work better to push the liquid than to suck the liquid a long distance into the pump inlet.

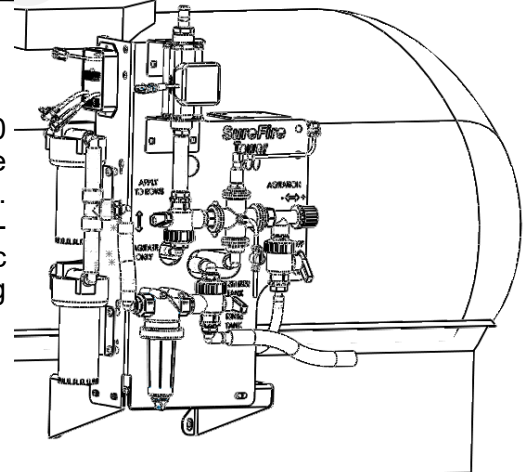

## 500 Gallon Elliptical Cradle Tower Mounting Bracket

Item Number **526-10-200500**

Mounts a Tower directly to the side of the SurePoint 500 gallon elliptical tank cradle. This bracket will mount the back of the tower just over 9" forward of the flat bracket mounting face.

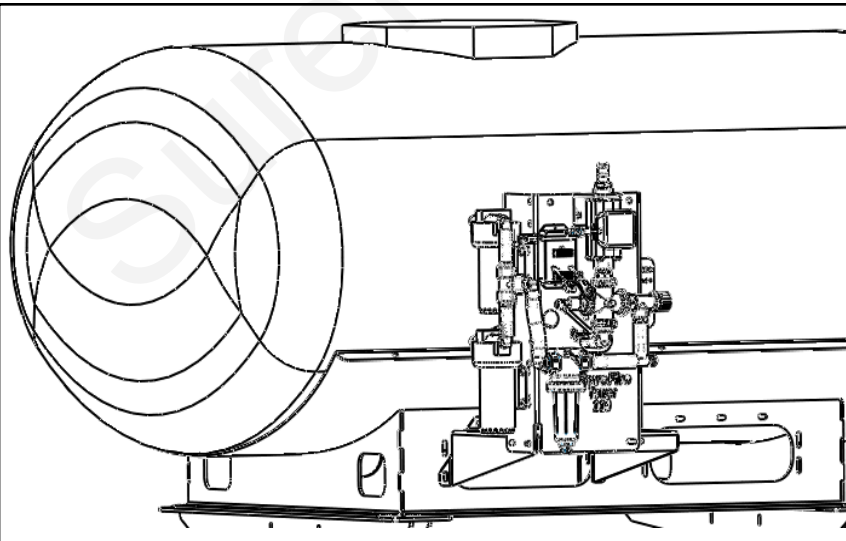

# Accelerator with Tower 200 Pump Panel



The Accelerator is a completely assembled and tested fertilizer system. It has a 55, 110, or 155 gallon tank resting in a custom molded tank base that doubles as a rinse water tank. This bolts to a steel frame with eighteen 5/8" mounting slots for flexible mounting to fit many situations. The Tower 200 is often used with the accelerator to work with the rinse tank base.

### Dimensions:

- 55 Gallon: 27" W x 54" L x 36" T
- 110 Gallon: 28" W x 72" L x 36" T
- 155 Gallon: 28" W x 72" L x 46" T

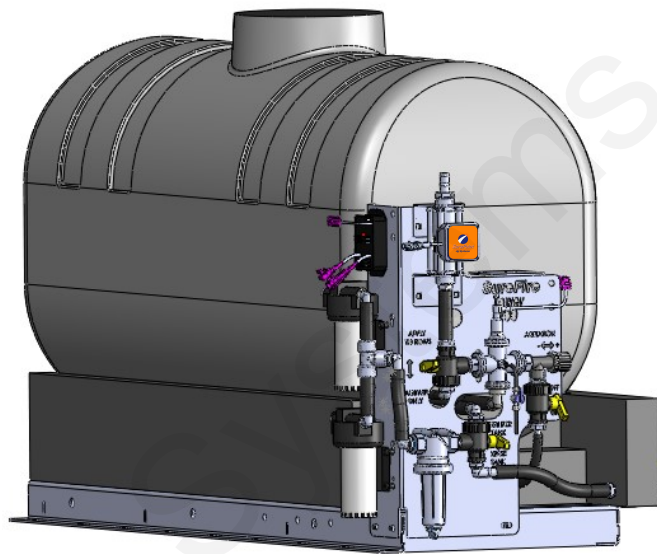

## Accelerator Z Mount Kit (fits 5" to 7" wide bars, included bolts fit 7" tall bar) Item Number 526-01-100300

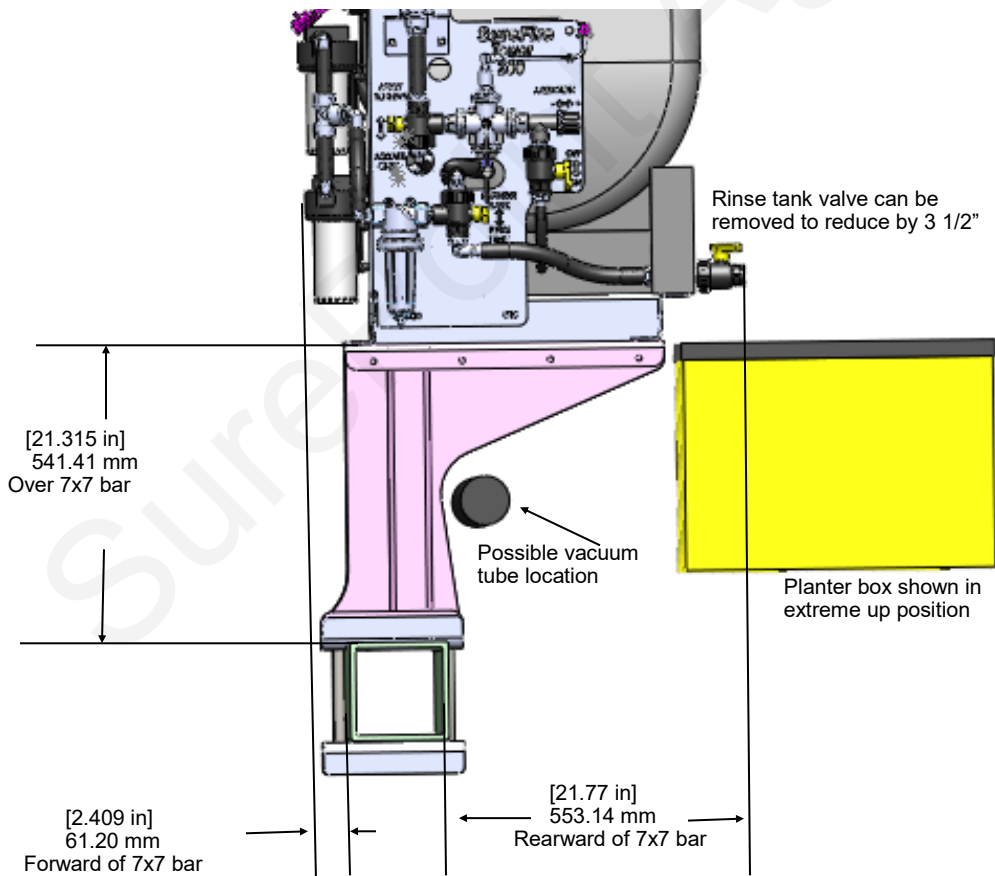

This mount kit includes two welded brackets to mount any of the 3 sizes of accelerator tanks above and offset from the 7x7 planter toolbar as shown.

# Tower 110 Plumbing Overview & Valve Operation

# E

Installation  
Overview

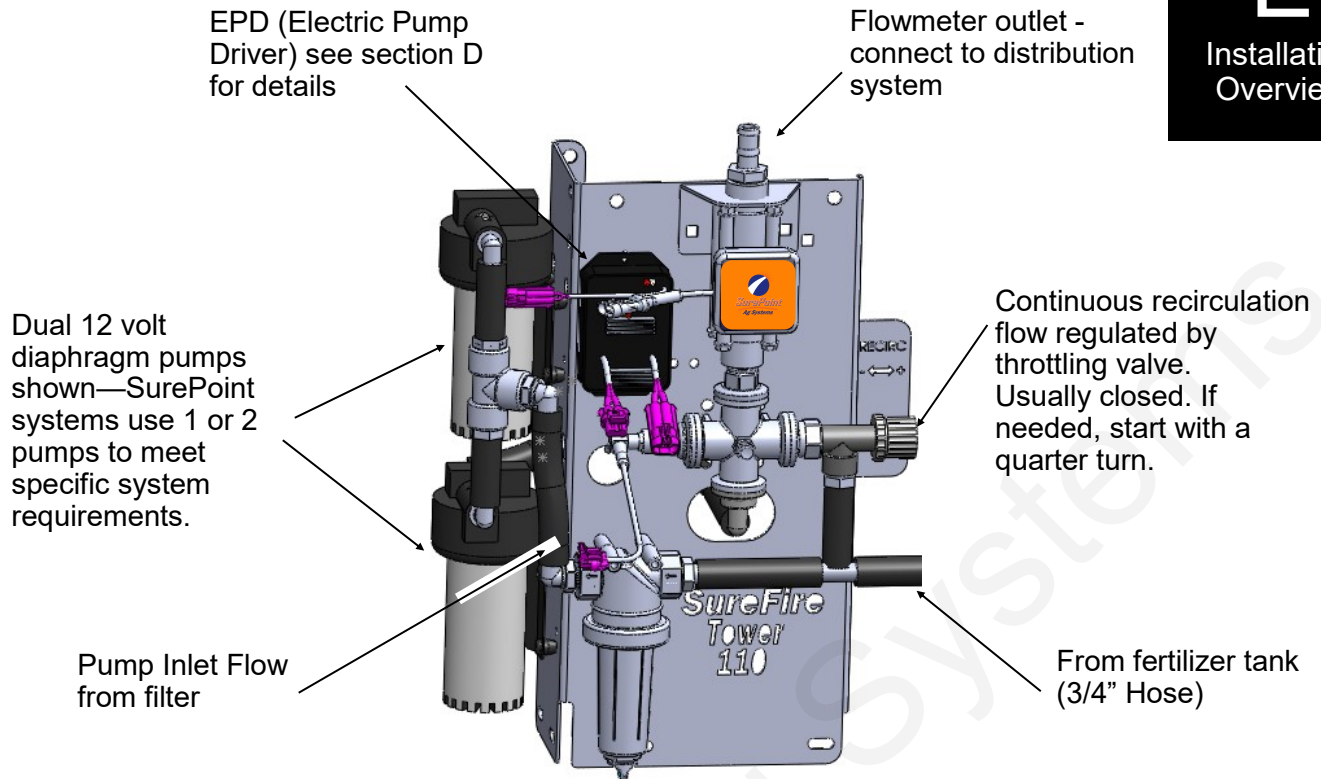

## Do I need recirculation flow?

Recirculation flow allows the pump(s) to run faster than if the total pump flow was applied to the ground. This is helpful when operating at very low flow rates. On a Tower 110 equipped with two 5.3 GPM pumps, you likely will NOT open the recirculation valve if applying over 1.5 GPM to the ground.

## How to use the Recirculation Adjust Valve:

Follow these steps to set the agitation adjust valve after your system is primed and tested:

1. On the Ag Leader display set a manual speed in speed input settings. Enter your field operating speed and rate. Turn your master switch on. The system will now operate at your Target Rate and Test Speed.
2. Start with the recirculation adjust valve completely closed and note the slow pump speed (by pump noise).
3. Open the agitate adjust valve slowly and note the increased pump speed and noise. The system is applying the same amount to the ground, the pumps are now running faster due to more recirculation flow.
4. Set the valve to somewhere in the middle based on visual observation of agitation flow needed.
5. On your Ag Leader display, verify the system has locked on to application rate at your agitation valve setting. (Generally, a quarter to a half turn of the knob is all that is needed.)

## Troubleshooting:

- If the system is applying a rate lower than your target, you need to close the agitation adjust valve some.
- If the system is applying a rate higher than you want and will not lock on rate, you need to open the agitation adjust valve some.
- If the rate is still fluctuating around your target and you have a two pump system, unplug one pump. At low flows, one pump may deliver the needed rate and produce a more stable flow.

## What if my product needs agitation?

- Tower Electric Pump systems can provide minimal agitation. On the Tower 110, simply remove the tee located below the recirculation valve. Connect the main hose from product tank to the filter and connect the tank agitation hose to the recirculation valve. Agitation will reduce the amount available to apply.

# Tower 200 Plumbing Overview

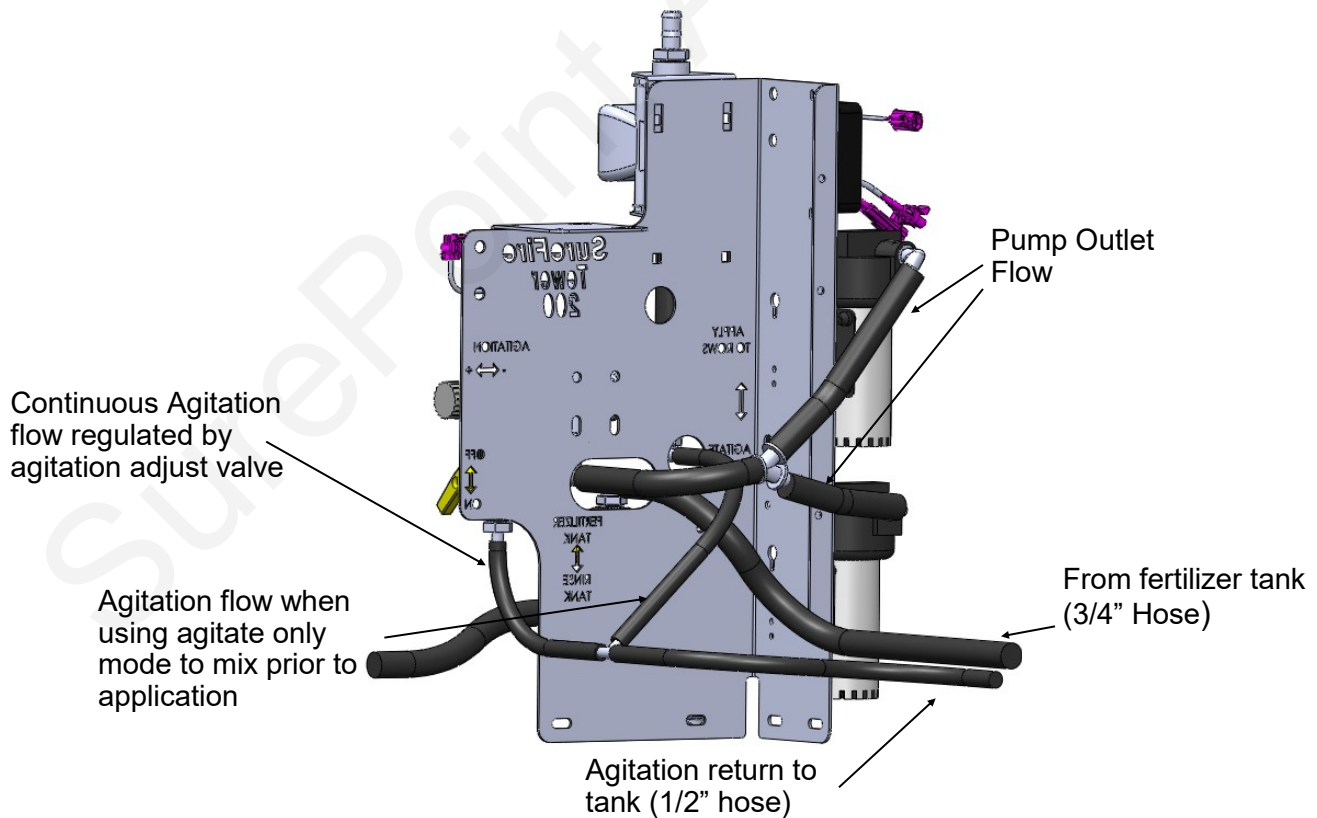
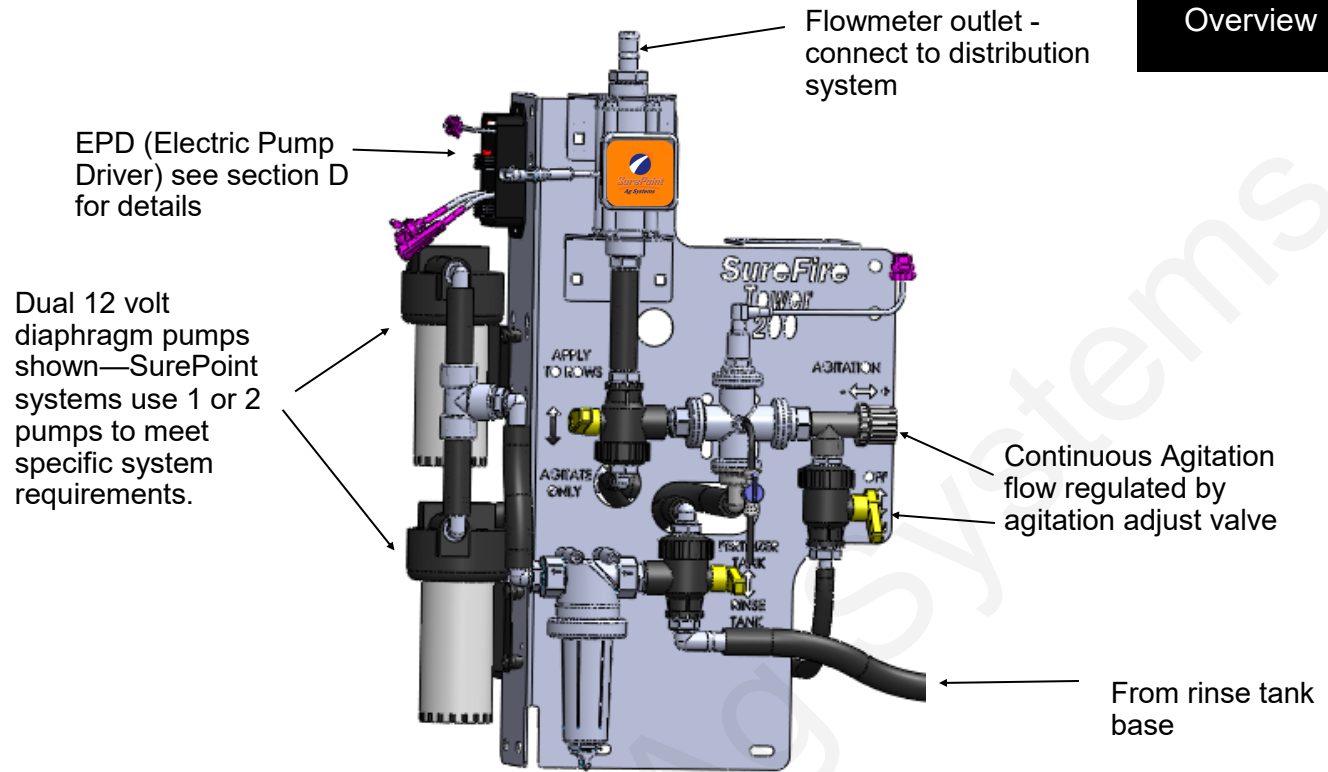

# Tower 200 Valve Operation

# E

Installation  
Overview

**System Mode Valve:** This valve selects if you will apply to the rows. **Valve must be in the up position for field operation.** Move down to Agitate Only for tank mixing prior to field operations.

**Tank Selection Valve:** This valve selects if product is pulled from the fertilizer tank or rinse tank. **For field operation the valve must be up.** Move down to Rinse Tank to flush fertilizer system.

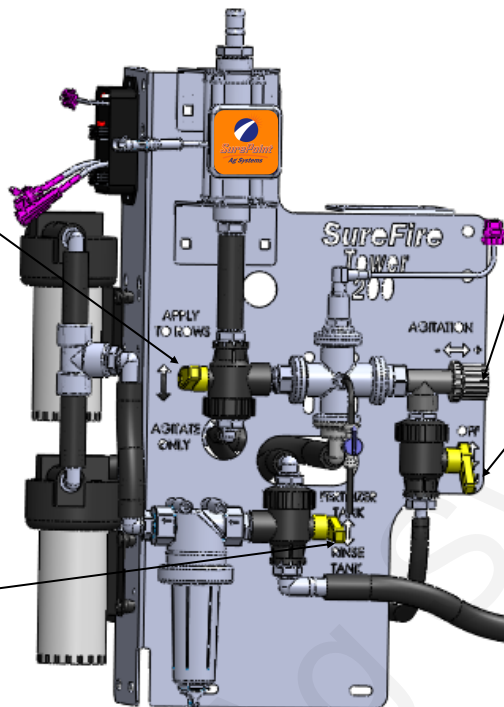

**Agitation Adjust Valve: RECIRCULATION KNOB:** This valve adjusts how much flow returns to the tank while working in the field. Normally closed. If needed, start with a quarter turn.

**Agitation On/Off Valve:** This valve will shut off agitation flow without the need to move the agitation adjust valve. **This valve must be closed when rinsing the system with product still in the fertilizer tank. If not closed, the rinse water will be injected into the fertilizer tank through the**

## How to use the Agitation Adjust Valve:

Agitation or recirculation flow serves two purposes. First, it mixes products that will separate. Second, it allows the pump(s) to run faster than if the total pump flow was applied to the ground. The pump(s) will become difficult to control if they are operated at the slowest speed possible. By circulating product back to tank, the pump(s) will run faster, producing a more stable flow.

**Follow these steps to set the agitation adjust valve after your system is primed and tested:**

1. On the Ag Leader display set a manual speed in speed input settings. Enter your field operating speed and rate. Turn your master switch on. The system will now operate at your Target Rate and Test Speed.
2. Open the Agitation On/Off valve.
3. Start with the recirculation adjust valve completely closed and note the slow pump speed (by pump noise).
4. Open the agitate adjust valve slowly and note the increased pump speed and noise. The system is applying the same amount to the ground, the pumps are now running faster due to more recirculation flow.
5. Set the valve to somewhere in the middle based on visual observation of agitation flow needed. (A quarter to a half turn is usually plenty.)
6. On your Ag Leader display, verify the system has locked on to application rate at your agitation valve setting.

## Troubleshooting:

- If the system is applying a rate lower than your target, you need to close the agitation adjust valve some.
- If the system is applying a rate higher than you want and will not lock on rate, you may need to open the agitation adjust valve some. Be sure the Zero Flow Offset is not set too high.
- If the rate is still fluctuating around your target and you have a two pump system, unplug one pump. **At low flows, one pump may deliver the needed rate and produce a more stable flow.**

# Ag Leader Integra Display Setup w/ LPCM

# F

Setup & Operation

The following pages have some of the screens used in setting up the Integra display for the Liquid Product Control Module (LPCM). Screens and navigation will be similar on the InCommand display. **Not all screens are shown. Your screens will be set up differently than what is shown for many of the screens. These are shown as examples of the navigation that you will go through in doing the setup. If your system is on a planter, there will be additional setup for that.**

## Configuration Setup



(Top Right of screen)

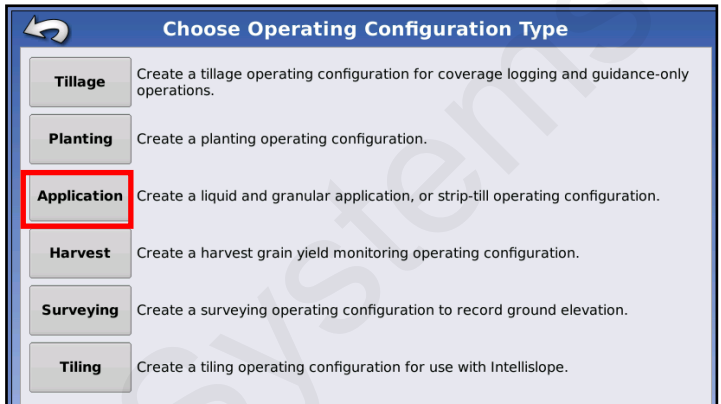
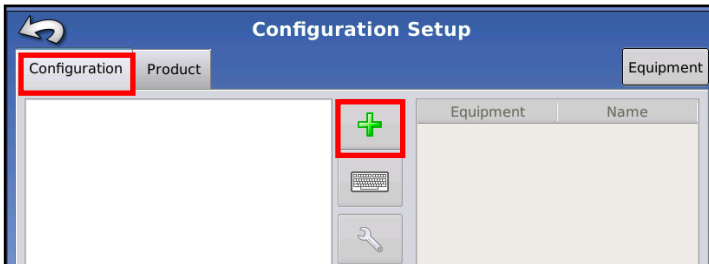

Select or Add a Tractor and enter the information.

Select or Add an Implement

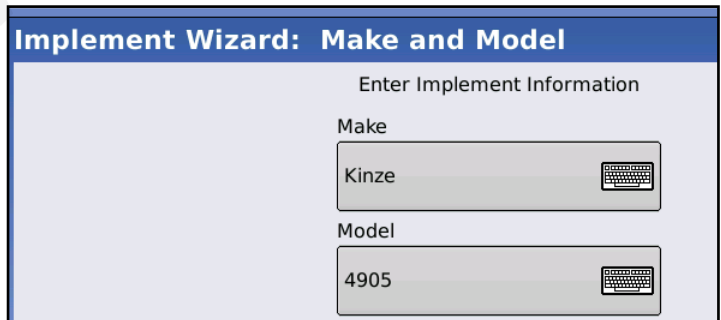
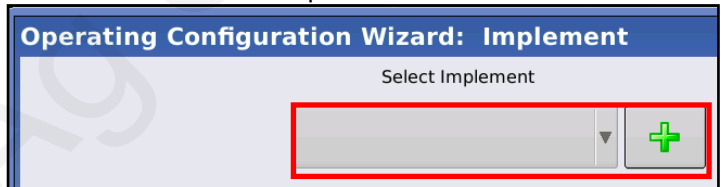
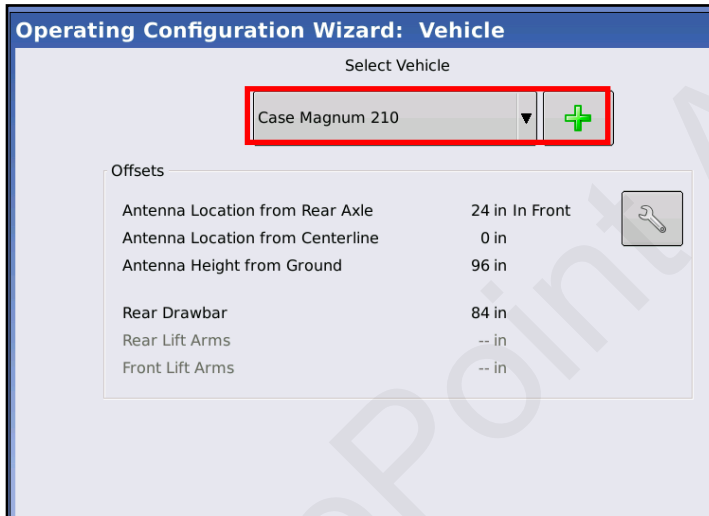

Enter the Implement Information



# Ag Leader Integra Display Setup w/ LPCM



Not all screens are shown. Your setup may be different than what is shown. These are shown for navigational assistance.

## Liquid Application Channel Setup

**Implement Wizard: Application Channels**

Type	Controller	Channel	Container

**Equipment Setup Wizard: Rate Controller**

Select Application Rate Controller

DirectLiquid

**Equipment Setup Wizard: Container**

Container Name Capacity Units

Main Tank  gallons

**Equipment Setup Wizard: Swath Width**

Enter Full Swath Width

Maximum of 10 Sections on LPCM

**Equipment Setup Wizard: Section Count**

Enter Number of Boom Sections

TIP: DO NOT enter the number of individual rows. For most implements, enter the number of swath sections that can be independently turned on and off.

**Equipment Setup Wizard: Section Configuration**

Enter Boom Section Widths from Left to Right

Section	Swath Width (ft)
1	7.5000
2	7.5000
3	7.5000
4	7.5000
5	7.5000
6	7.5000
7	7.5000
8	7.5000

TIP: The implement is divided into equal section sizes by default. To modify the sections, press the keypad button for each section that needs to be changed.

**Equipment Setup Wizard: Application Point Offset**

Enter Distance from Hitch to Application Point (front to back)

**Implement Wizard: Application Channels**

Type	Controller	Channel	Container
Liquid	DirectLiquid		Main Tank

# Ag Leader Integra Display Setup w/ LPCM



Not all screens are shown. Your setup may be different than what is shown. These are shown for navigational assistance.

## Controller Setup

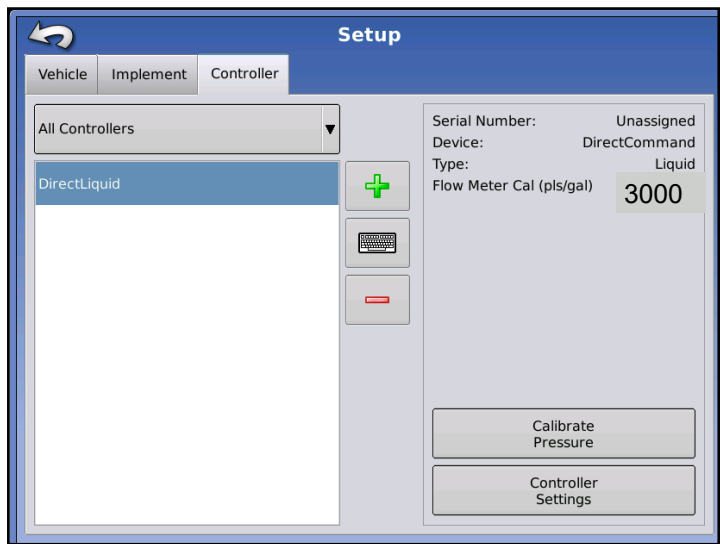
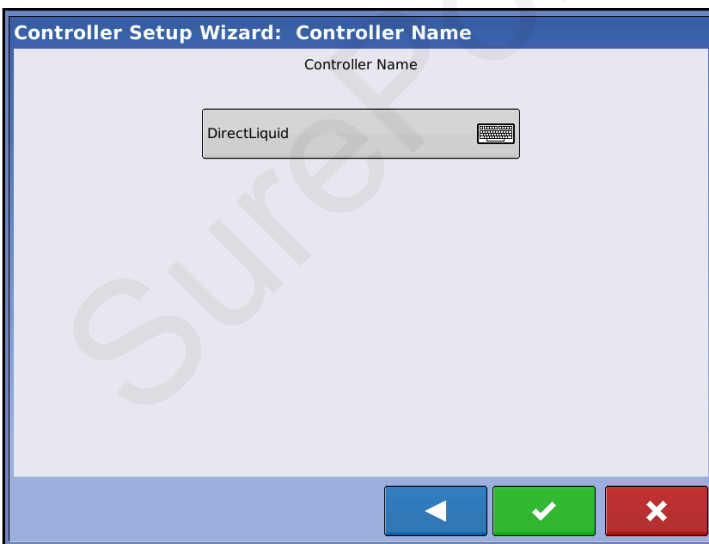
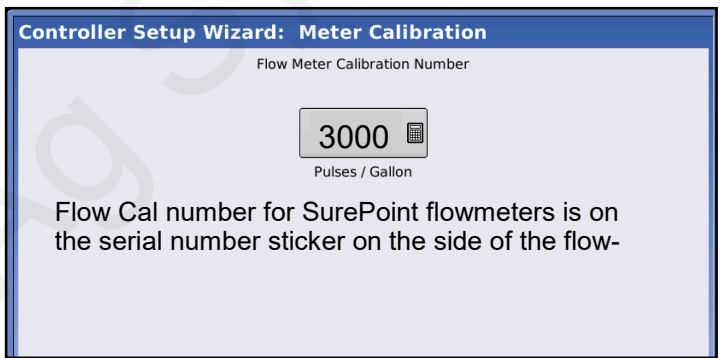
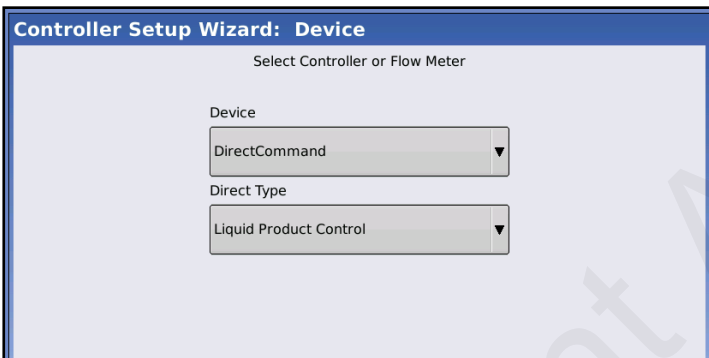
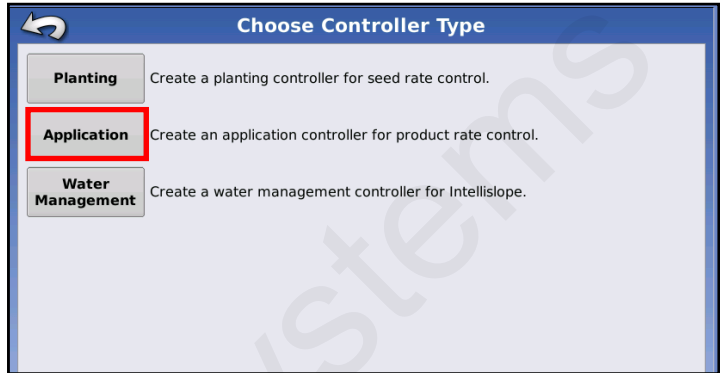
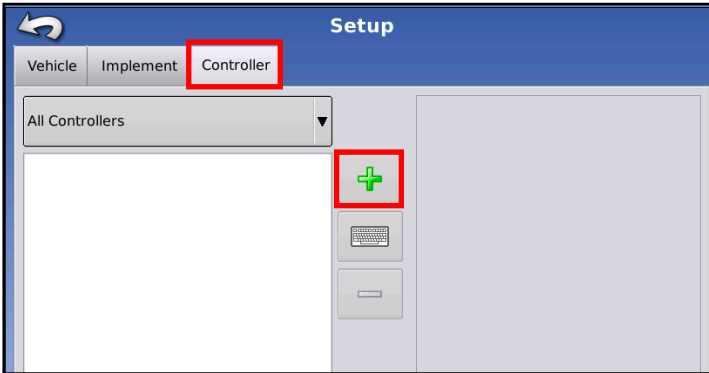

# Ag Leader Integra Display Setup w/ LPCM



Not all screens are shown. Your setup may be different than what is shown. These are shown for navigational assistance. Use these numbers / settings.

## Configuration Setup - Controller / Control Valve Settings - Manual Speed Entry

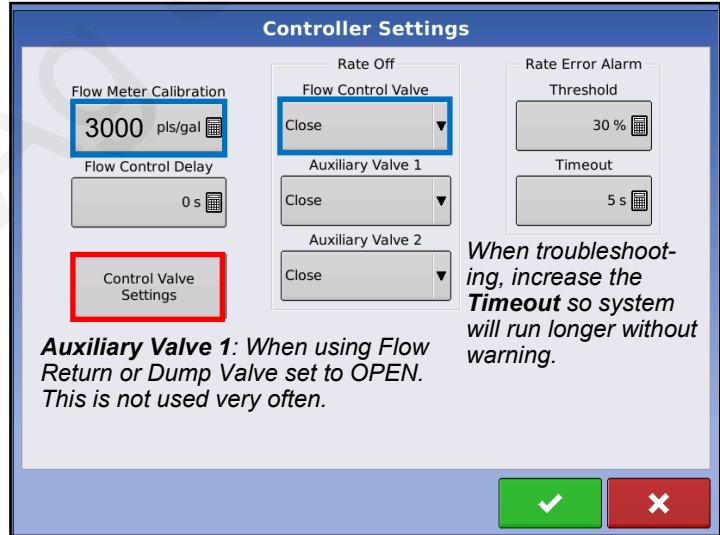
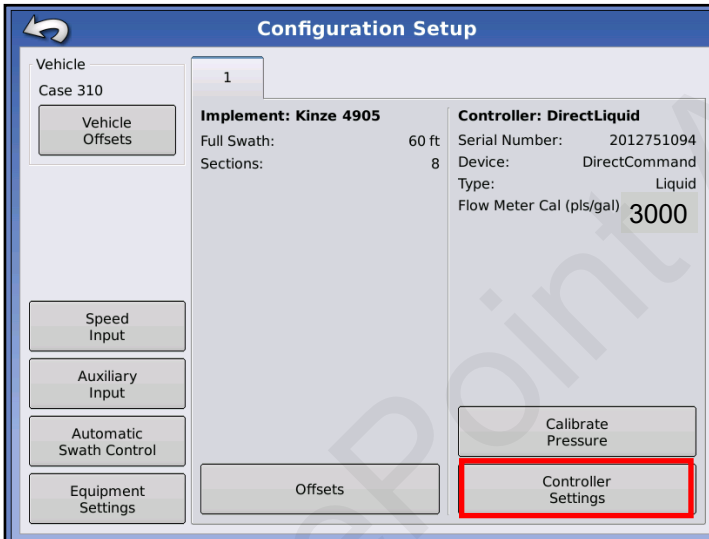
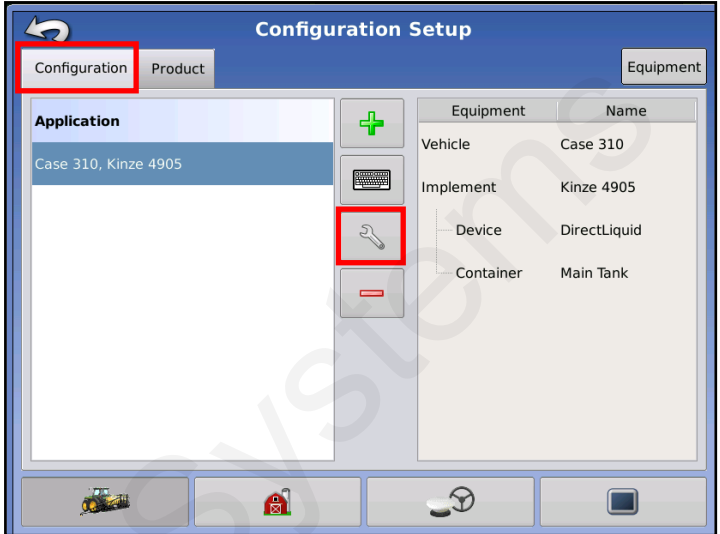
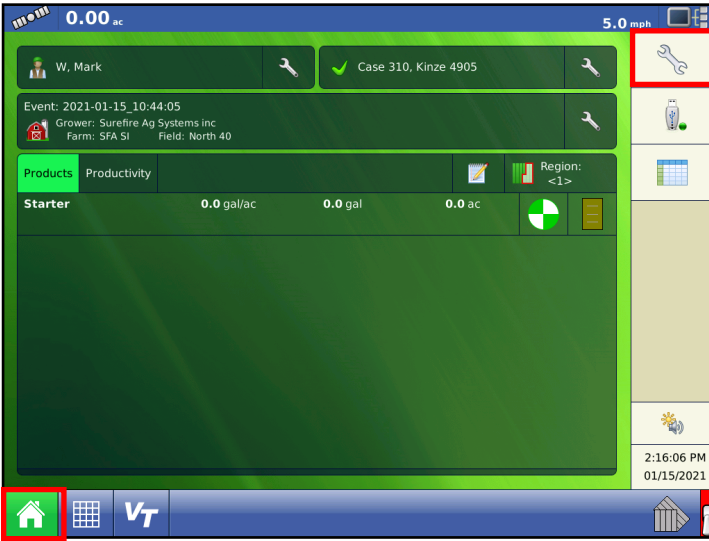

Adjust PWM Gain as needed in the field (decrease if rate is bouncing around; increase to adjust quicker)

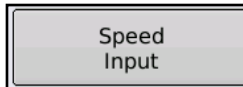

To enter a Manual Speed so you can run a test while sitting still.

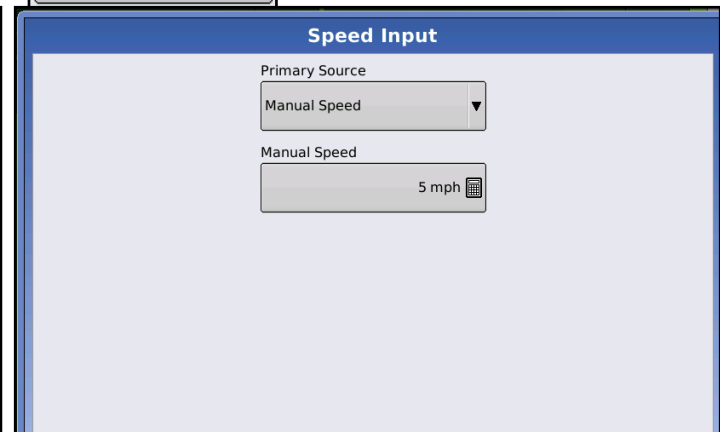
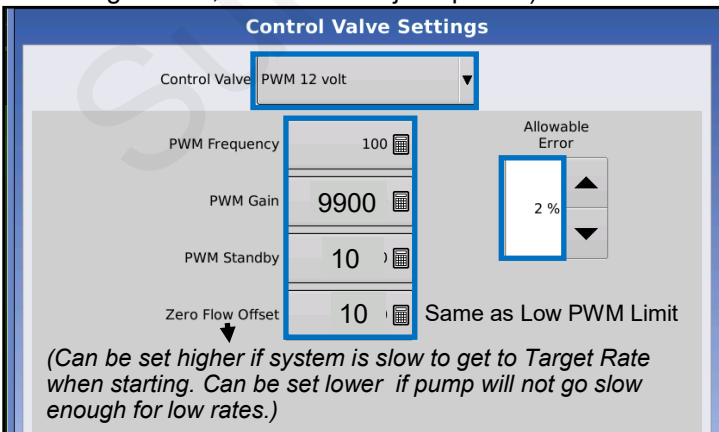

# Ag Leader Integra Display Setup w/ LPCM



Not all screens are shown. Your setup may be different than what is shown. These are shown for navigational assistance.

## Calibrate Pressure Sensor, Swath Control, Auxiliary Input, Rate Smoothing

Calibrate Pressure

**Pressure Sensor Calibration: Step 1 of 3**

Select Pressure to Calibrate

Main

**Pressure Sensor Calibration: Step 2 of 3**

Enter a Pressure value as a Set Point

0 PSI

Enter Voltage / Pressure Ratio

50.0 mV/PSI

50 mV/PSI for standard Sure-Point 100 PSI, 0 to 5 volt sen-

Reset to Default

Automatic Swath Control

**Automatic Swath Control**

Application

Outside Boundary Option

- Keep Unchanged
- Turn Section Off

Coverage Option

- Minimize Skip
- Minimize Overlap
- User Defined 100 %

Look-Ahead Settings

**Look Ahead Settings**

DirectLiquid

Turn-On: 1.0 s

Turn-Off: 0.5 s

**Turn On / Turn Off:** Set this as needed to get product to hit the ground and then to stop at the right time. Will only work if the operator starts the pass and ends the pass at the same speed each time.

Auxiliary Input

**Auxiliary Input**

	DirectLiquid
F1 (Master)	Channel On/Off
F2 (Switch 1)	1
F3 (Switch 2)	2
F4 (Switch 3)	3
F5 (Switch 4)	4
F6 (Switch 5)	5
F7 (Switch 6)	6
F8 (Switch 7)	7
F9 (Switch 8)	8
F10 (Switch 9)	
F11 (Switch 10)	
External 1	
External 2	

Assign

Master Source

Switch

Equipment Settings

**Equipment Configuration Settings**

Rate Outside of Field

Zero

Rate Change Look-Ahead

0 sec

Rate Display Smoothing

**Rate Change Look Ahead:** Set this if needed when using a prescription. Typically, leave at 0.

# Ag Leader Integra Display Setup w/ LPCM



Not all screens are shown. Your setup may be different than what is shown. These are shown for navigational assistance.

## Configuration Setup / Product Setup / Equipment Setup

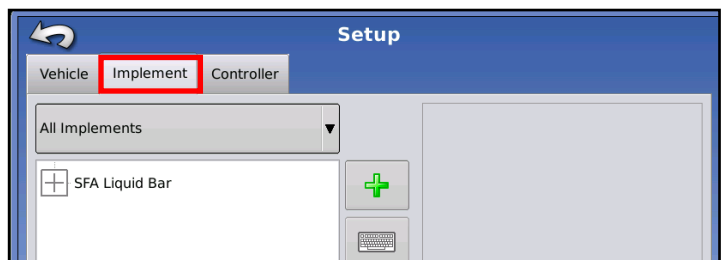
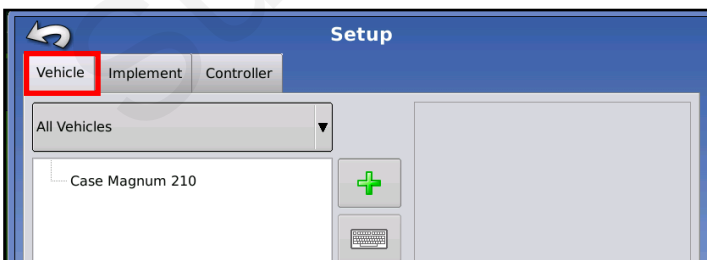
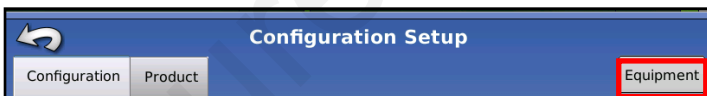
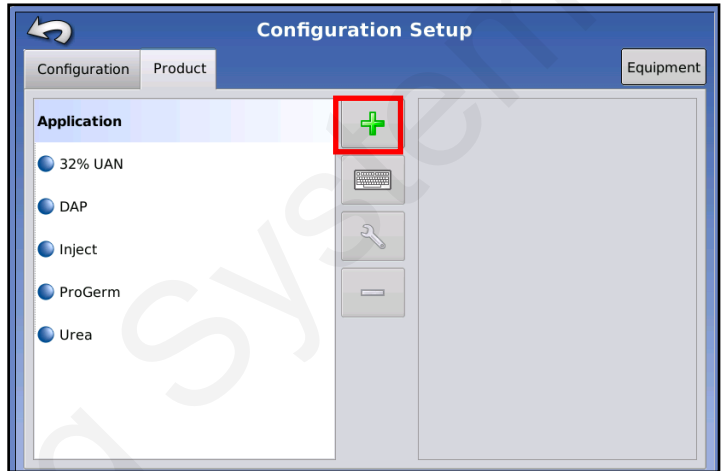
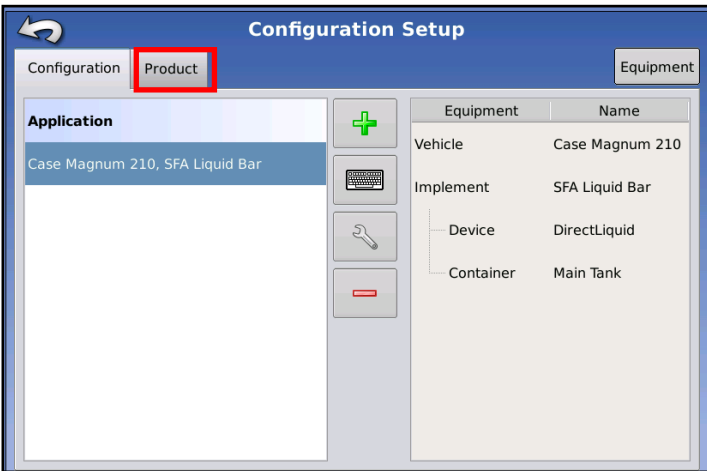

# LPCM Run Screen



Your screen will look different than this, depending on the systems you are operating. This page shows the basic elements of a liquid system.

The Grid button in the lower left corner of the screen brings up the Map screen for Run Time Operations.

Ground Speed      Device Information (Diagnostic) Button

To test the system, enter a Manual Speed. Turn Auto Swath OFF. Select a Rate, turn on the Master Switch and section switches. System should begin running and lock on to the Target Rate. You can turn individual sections ON and OFF. Press on the **Diagnostic** button to see system parameters, especially PWM Duty Cycle and Flow Meter Frequency and Pulse Count.



When testing with water, the pressure will be much less than it will be with fertilizer. This may mean that some rows may not flow because there is not enough pressure to keep all the check valves open. Increase the Rate to build more pressure.

# Ag Leader Integra Display Setup w/ LPCM

Not all screens are shown. Your setup may be different than what is shown. These are shown for navigational assistance.



## Diagnostics - Device Information



**Devices**

CAN A    CAN B

DISPLAY

128 Liquid Product Module

233 Auxiliary Input Module

Firmware: 1.19.0  
Firmware ID: DC LIQUID  
Hardware ID: 4000405  
Product ID: DC LIQUID  
Serial Number: 2012751094  
Revision: 4.2.0.0  
Run Time: 1035976:05:12  
Boot Counter: 399  
CAN Name: A00C81010C21D906

Diagnostics

**Liquid Diagnostics**

Controller Name DirectLiquid

Serial Number 2012751094

Main Pressure (kPa) 234

Agitation Pressure (kPa) N/A

Auxiliary Pressure (kPa) 0

PWM Duty Cycle (%) 39.78

Flow Meter Signal Frequency (Hz) 83

Flow Meter Pulse Count 30301

**PWM Duty Cycle** is an indication of how fast the controller is telling the pump to run. The controller adjusts the PWM Duty Cycle to speed the pump up or to slow it down.

An electric pump will generally run between 10% and 60%.

Check this during field operation to get an idea of what is normal.

This should be fairly stable ( $\pm 2\%$ ) when travelling at a steady speed through the field.

The Flow Meter Signal Frequency should be stable ( $\pm 2$  or 3).

# Initial Operation - LPCM--Manual Mode

*SurePoint recommends you perform these exact steps with water to verify system is correctly installed and ready for field use.*

# F

Setup &  
Operation

0.71 ac

Ground Speed → 5.0 mph

MANUAL

Diagnostics

Product Tab 32% UAN gal/ac

Target Rate OFF

Actual Rate 9.00

1 15 Increase

2 9 Decrease

M

R

Flow: 1.6 gal/min

Container: 345 gal

If this bar is not showing, press the Product Tab (above).

Section Indicator - will be green in Run mode.

20 ft 0 in 100%

Pressure (PSI)

Main: 34

Agitation: 0

Auxiliary: 0

Home Grid VT

1. Enter manual mode by pushing the “M” button in the upper right corner of the screen. You can tell you are in manual mode when the “Target” Rate says “OFF”. Turn AutoSwath OFF.
2. If using implement lift switch, move implement switch to lowered position. If not using implement switch, jumper must be installed (see wiring diagram in section D).
3. On the Switch Box, turn the master switch On. Turn section switches On and Off to check proper section valve operation. Leave all section valves On.
4. Use up arrow on right side of screen to increase flow. Does “Flow Rate” display a flow rate? Is it stable after the system is primed? Do increase & decrease buttons increase & decrease flow?
5. When you can increase and decrease flow using the arrows, you are ready to move to the next step.
6. Conduct a catch test to verify the flowmeter calibration is correct. It is unusual if the Flow Cal number needs to be changed. (The most accurate method to measure the volume of water run is to place a container under every nozzle and add together the amount from each nozzle. This assures that 100% of the water is collected and that all rows are equal. At a minimum, collect water from 4-6 rows. **NEVER base a calibration on a single row catch.** It is important to perform this procedure at a flow rate similar to that which will be used in the field.)
7. Press the **Diagnostic** button (upper right corner) to see more system information while it is running.

# Setup and Operation – InCommand / ISO Liquid & L2 Rate Controller



Go to [support.agleader.com](http://support.agleader.com) or use the InCommand manual or Quick Reference Guide to help with setup. [See Ag Leader 2006017 Liquid ISO Manual.](#)

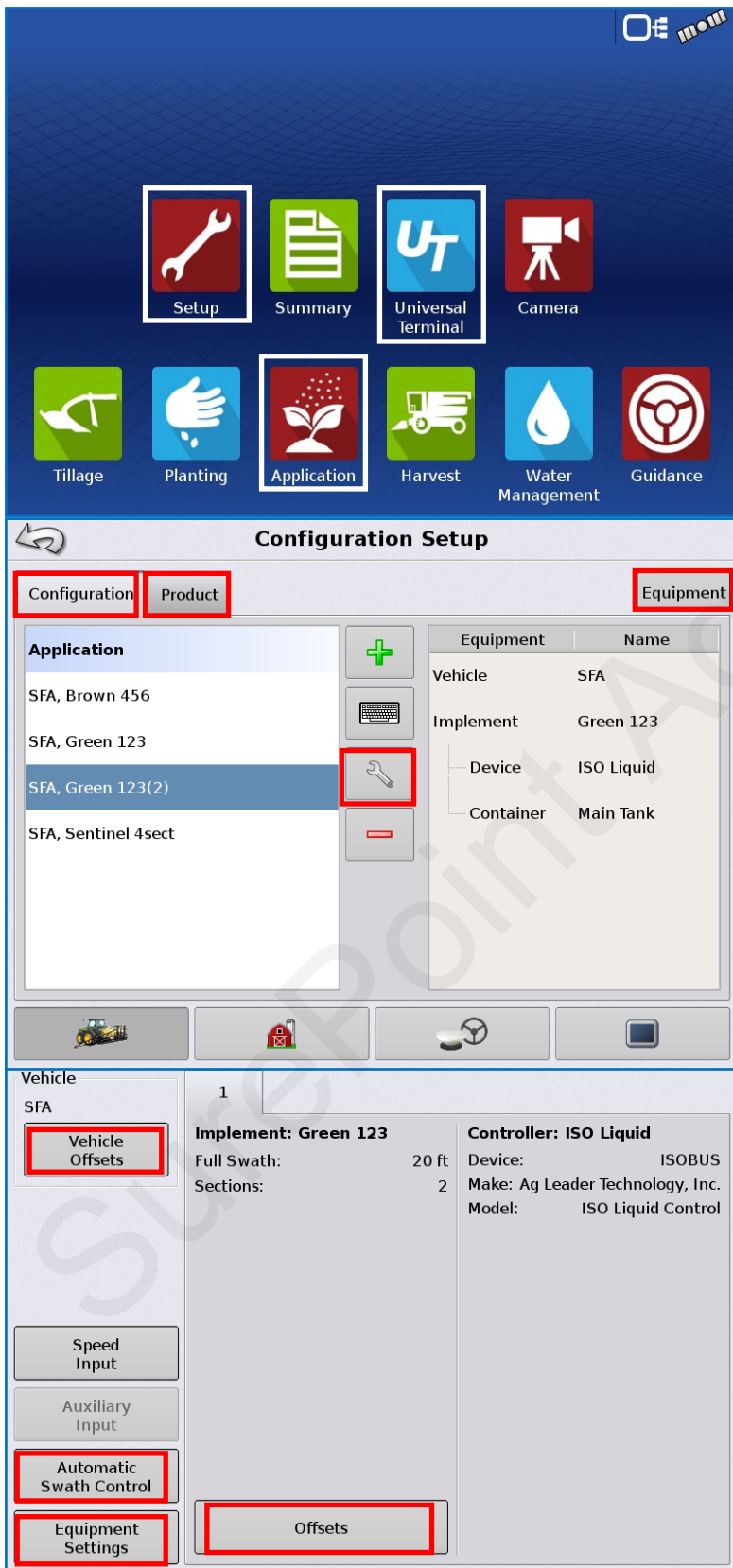

Sample screens are shown here. Your set-up will probably be different. Not all the set-up screens are shown here. The screens shown should help you navigate through the system.

If you are setting up the **L2 Rate Controller**, the screens will be similar. See [Ag Leader documentation :Part No 2006954 - Direct Command L2 Rate Controller Manual.](#)

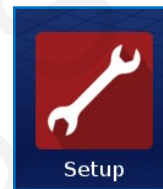

You may not use all these screens.

You may use other screens not shown here.

# Product Setup



**Configuration Setup**

Configuration **Product** Equipment

**Application**

- 28% UAN

+  
Keyboard  
Wrench  
-

Add a product.

Edit a product.

Set up units and other product information.

Set up the Rate Legend as desired.

**28% UAN**

General **Rate Legend**

Product Units  
gallons

Manufacturer  
None

EPA Number

Restricted Use Pesticide

**28% UAN**

General **Rate Legend**

**Attribute: Rate**

- 30.0 - (36.0)
- 24.0 - 30.0
- 18.0 - 24.0
- 12.0 - 18.0
- 6.0 - 12.0
- (0.0) - 6.0

Average  
18

Range Spacing  
6

Color Scheme  
Green

Ranges  
6

Reset to Default Legend

# Configuration Setup

## Speed Input

### Automatic Swath Control

### Equipment Configuration Settings



**Speed Input**

Primary Source

Backup Source

Auxiliary Device Channel

Auxiliary Channel Calibration  
   
Pulses / 100 ft

**Speed Input**

Primary Source

Manual Speed

Set a **Manual Speed** to run the system while standing still.

**Automatic Swath Control**

Application

Outside Boundary Option

Keep Unchanged

Turn Section Off

Coverage Option

Minimize Skip

Minimize Overlap

User Defined

**Look-Ahead Settings**

ISO Liquid, Boom (2)      Turn-On:       Turn-Off:

Set the **Look-Ahead Settings** so liquid application starts and stops at the correct time.

**Equipment Configuration Settings**

Rate Outside of Field

Rate Display Smoothing

**Rate Change Look-Ahead**

**Implement Switch Polarity**

When using an Implement Switch, set **Implement Switch Polarity** for proper operation.

When using a variable rate prescription, set **Rate Change Look-Ahead** as desired.

Implement Switch Polarity

Implement Switch Polarity

# Equipment Setup

## Vehicle Implement Controller



Setup

Vehicle Implement Controller

All Vehicles

SFA

+ (Add)

Keyboard (Direct Command)

- (Remove)

## Vehicle

Setup

Vehicle Implement Controller

All Implements

- + Brown 456
- + Green 123
- + Sentinel 4sect

+ (Add)

Keyboard (Direct Command)

- (Remove)

## Implement

Setup

Vehicle Implement Controller

All Controllers

- DirectLiquid
- DirectLiquid(2)
- ISO Liquid
- Liquid Fertilize
- SeedCommand
- SentinelFlow6

+ (Add)

Keyboard (Direct Command)

- (Remove)

Serial Number: Unassigned  
Device: DirectCommand  
Type: Liquid  
Flow Meter Cal (pls/gal) 3000.00

Calibrate Pressure

Controller Settings

## Controller

If **Direct Command** is selected, there will be a button in the bottom right corner—**Controller Settings**- which will take you to the screens on the next page.

# Controller Settings



### Controller Settings

<b>Flow Meter Calibration</b> <input type="text" value="3000 pls/gal"/>	<b>Rate Off</b> <b>Flow Control Valve</b> <input type="text" value="Close"/>	<b>Rate Error Alarm</b> <b>Threshold</b> <input type="text" value="30 %"/>
<b>Flow Control Delay</b> <input type="text" value="0 s"/>	<b>Auxiliary Valve 1</b> <input type="text" value="Close"/>	<b>Timeout</b> <input type="text" value="30 s"/>
<input type="button" value="Control Valve Settings"/>	<b>Auxiliary Valve 2</b> <input type="text" value="Close"/>	

## Control Valve Settings

### Control Valve Settings

Control Valve:

PWM Frequency	<input type="text" value="100"/>	<b>Allowable Error</b> <input type="text" value="2 %"/>
PWM Gain	<input type="text" value="9900"/>	
PWM Standby	<input type="text" value="10"/>	
Zero Flow Offset	<input type="text" value="10"/>	

**Zero Flow Offset** (PWM Low Limit) may be lowered if pump needs to run slower to get down to rate. Zero Flow Offset may be raised to help system get to rate quicker on startup.  
**PWM Standby** is only used if Flow Control Valve is set to HOLD. PWM Standby cannot be lower than Zero Flow Offset.

# Console Setup / ISO Settings / Universal Terminal

Console Setup		ISOBUS Settings	
<b>General</b>   Display   Features   AgFiniti   Advanced Brightness: Auto Volume: 70 % Time / Date: 12:51:50 PM, 01/28/2019 Time Zone: America (Chicago)	Language / Country: English / US Operating Units: Imperial <input type="checkbox"/> Enable Video <input type="button" value="ISOBUS Settings"/>	<b>Universal Terminal</b> <input checked="" type="checkbox"/> Enable Universal Terminal <input checked="" type="checkbox"/> Broadcast Display Speed (ISO GBSD) <input checked="" type="checkbox"/> Broadcast GPS (J1939) <input checked="" type="checkbox"/> Auxiliary Module Support Function Instance: <input type="text" value="0"/>	<b>Task Controller</b> <input checked="" type="checkbox"/> Enable Task Controller <input checked="" type="checkbox"/> Section/Rate Compatibility <input checked="" type="checkbox"/> ECU Section Delays Function Instance: <input type="text" value="0"/>
<input type="button" value="Tractor"/> <input type="button" value="Pump"/> <input type="button" value="Valve"/> <input checked="" type="button" value="Terminal"/>		<b>File Server</b> <input type="checkbox"/> Enable File Server	

# Ag Leader Liquid ISO & Universal Terminal

# F

Setup &  
Operation

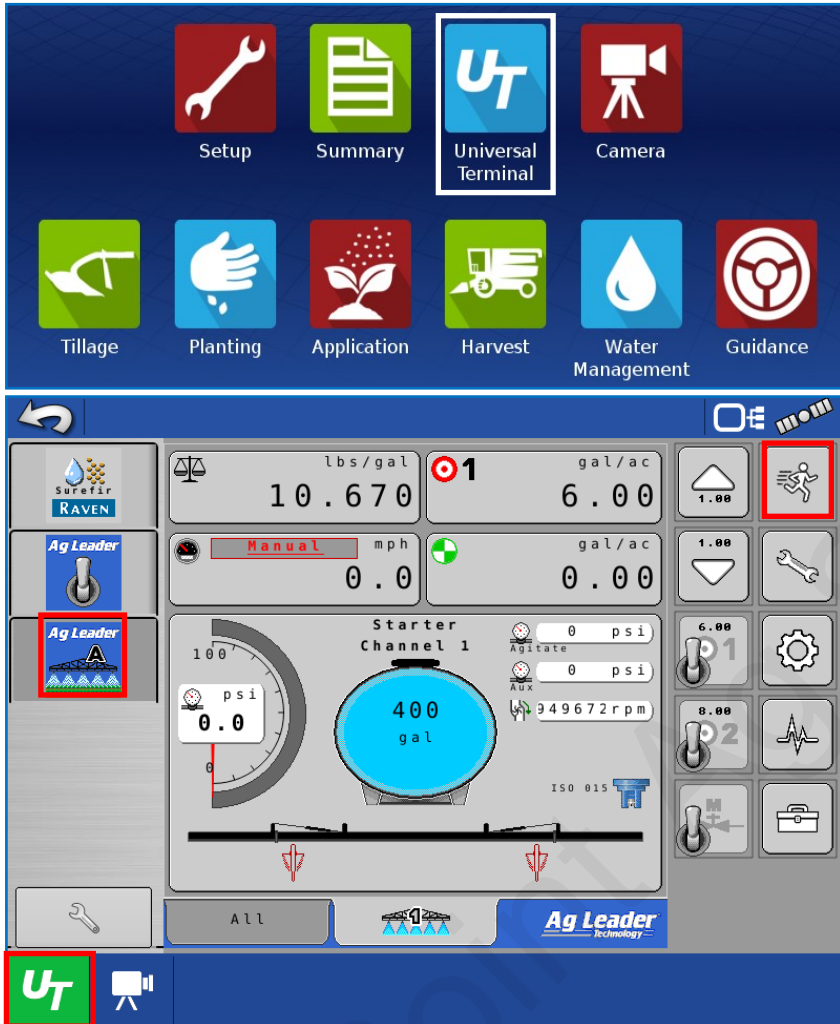

Universal Terminal

Ag Leader Liquid ISO

Run Screen

Settings

Calibration

Diagnostics

Toolbox

If you are setting up the **L2 Rate Controller**, the screens will be similar. See [Ag Leader documentation :Part No 2006954 - Direct Command L2 Rate Controller Manual](#).

For Ag Leader documentation for **Liquid ISO Module**, see [Ag Leader 2006017 Liquid ISO Manual](#).

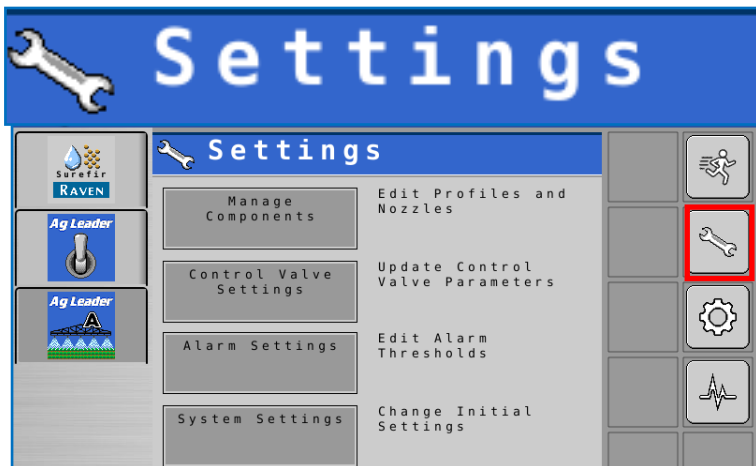

## Manage Components



## Control Valve Settings

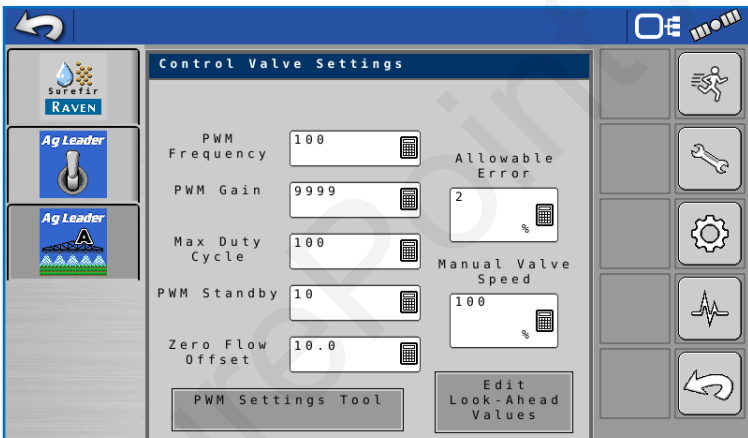

PWM Frequency 100  
 PWM Gain 9900  
 Max Duty Cycle 100  
 PWM Standby 10  
 Zero Flow Offset 10  
*Zero Flow Offset is Low PWM Limit.  
 Lower this if pump will not go low enough.  
 Raise this to get to rate quicker on startup.*

## Look-Ahead Settings

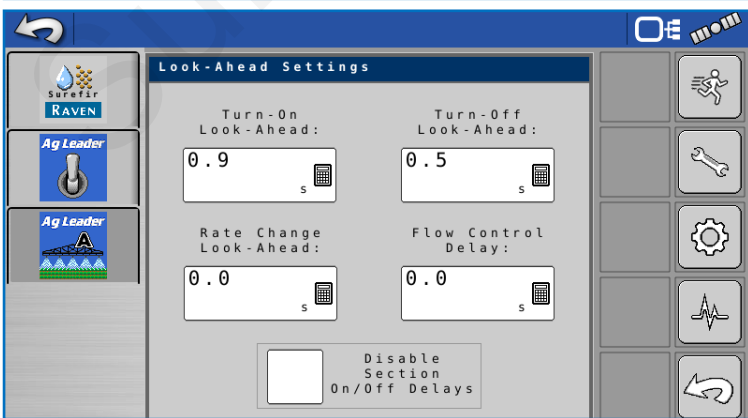

# Pressure Sensor

The screenshot displays the 'Calibration' interface in four sequential steps:

- Step 1: Calibration Overview**
  - Channel: 1
  - Pressure Sensor: Main (checked), Agitate (unchecked), Aux (unchecked)
  - Flow Sensor: checked
  - Pump Sensor: unchecked
  - Speed Sensor: checked
- Step 2: Select Sensor**
  - Sensor: Main
- Step 3: Select Calibration Method**
  - Single Set Point
- Step 4: Enter Calibration Number**
  - 50.0 mV/psi

# Calibration

**F**  
Setup & Operation

## Flow Sensor

## Pump Sensor

Calibrate Flow Sensor:

Please enter a flow calibration number below

Calibration Number:  pulses/gal

Navigation: Back, Forward, Cancel (X)

Calibrate Pump Sensor:

Enter Calibration Number

Calibration Number:  pulses/rev

Not used on electric pump system

Navigation: Back, Confirm (Checkmark), Cancel (X)

**Diagnostics**

Channel 1    CAN NAME: A00CB0080C2029F8  
 SN: 2150010744    CAN ADDR: 0x81

Pressure Sensor	Type	Count
Main	Voltage	44130
Agitate	None	180
Aux	None	180
Flow Sensor	Pulses	Count
Main	0	0
Aux	0	0
Valve	State	
Control	Duty Cycle	
Aux 1	Off	
Aux 2	Off	

Decrease Flow    Increase Flow

Toggle Aux 1    Toggle Aux 2

Status    Control    Ag Leader Technology

If you are setting up the **L2 Rate Controller**, the screens will be similar. See [Ag Leader documentation :Part No 2006954 - Direct Command L2 Rate Controller Manual](#).

For Ag Leader documentation for **Liquid ISO Module**, see [Ag Leader 2006017 Liquid ISO Manual](#).

# Run Screen Settings

Press on the box on the Run Screen to:  
 Enter a Manual Speed  
 Set up Rate 1 and Rate 2  
 Turn on Rate Smoothing  
 Set the amount of liquid in the Tank  
 Set up the Pressure Dial on the Run Screen



### Speed Source Settings

Speed Source:  
 ISO GBSD

Manual Override  
 5.0 mph

lbs/gal: 10.670  
 gal/ac: 5.00  
 Manual: 5.0 mph  
 gal/ac: 0.00  
 Starter Channel 1: 399 gal  
 psi: 0.1  
 Agitate: 0 psi  
 Aux: 0 psi  
 rpm: 0

### Rate Control Settings

1: 5.00 gal/ac  
 2: 8.00 gal/ac  
 Increment: 0.50 gal/ac

### Actual Rate Settings

Use Rate Smoothing?

### Pressure Settings

Max Graph Pressure: 100 psi  
 Prime/Standby Pressure: 0 psi

### Container Settings

399 gal

↑ ? ↓  
 Container Alarms

# Ag Leader Run Screen for ISO Liquid & L2 Controller



Select **Application** to go through the screens that will take you to the traditional “Ag Leader run screen” for the Liquid ISO Module.

The Run Screen is shown on the next page.

The liquid may be run from this screen or from the UT screen.

### Operating Configuration

✓ SFA, Green 123(2)

Equipment	Name
Vehicle	SFA
Implement	Green 123
Device	ISO Liquid
	<input checked="" type="checkbox"/> Generic ISOBUS
Container	Main Tank

### Event Selection

Start New Event

Event: 2019-01-29\_12:31:26

### Product Selection

ISO Liquid, Boom (2)

Active   
  28% UAN

### Options

Region

<1>

Controlling Product

28% UAN (gal)

### Management

Growing Season

2019 Crop

Grower

SureFire Ag Systems

Farm

North 40

Field

South 20

Enable Management

# Ag Leader Run Screen for ISO Liquid & L2 Controller

# F

Setup & Operation

The liquid may be run from this screen with the traditional Ag Leader look or from the UT screen.

5.80 ac | 5.0 mph

28% UAN gal/ac

8.00

8.00

1 6

2 8

M

Flow: 1.6 gal/min

Container: 110 gal

20 ft 0 in 100%

16 PSI

No Nozzle

Prime

Agitation: 0 PSI

Auxiliary: 0 PSI

Pump Speed: 0 rpm

## Rate Control Settings

Rate Control Containers

28% UAN (gal)

Rate 1 6.00

Rate 2 8.00

Increment 0.50

Minimum Flow 0.00 gal/min

Rx

# Electric Pumps Won't Run

*Is there a jumper in the Implement Lift Switch connector on the main harness connected to the Liquid Product Control Module? If there is not an implement lift switch plugged in, there must be a jumper between Pins A & C of this connector. If this is not done, the system will not run.*



## EPD Status Lights

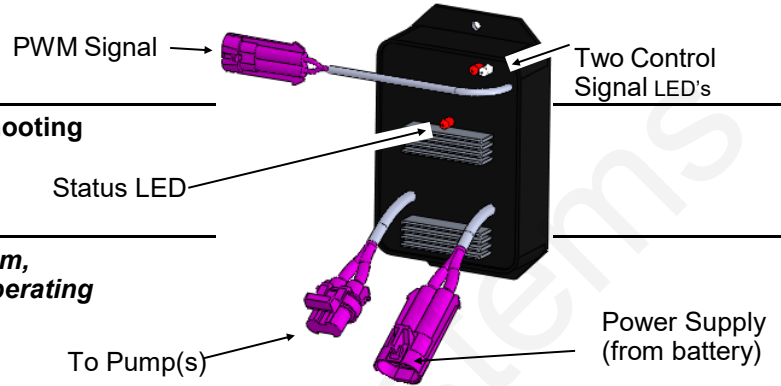

Status LED	Status Description	Troubleshooting Steps
<b>On Steady</b>	<b>Power input is good and PWM input Signal is detected</b>	<b>No Problem, Typical operating condition.</b>
<b>Steady Blink</b>	<b>Power input is good and PWM signal is not detected. This light will go off after 5 minutes of inactivity.</b>	<b>Typical 'Off' Condition. If pumps should be on:</b> <ol style="list-style-type: none"> <li><b>Inspect wiring and connectors</b></li> <li><b>Check voltage at PWM connector to EPD, should be 1-12 volts to turn on.</b></li> <li><b>Check voltage on PWM pins on LPCM (8-pin Channel 1 connector: Pins 2 and 7)</b></li> </ol>
Blink once, pause, blink once, pause	Open circuit between motor output and motor.	Check harness and connectors to motor. If using two motors, plug each in separately directly to EPD (bypassing Y-harness)
Blink twice, pause, blink twice, pause	Output short circuit detected.	<ul style="list-style-type: none"> <li>Check motor wiring</li> </ul>
Three blinks, pause, three blinks, pause	Overcurrent condition	<ul style="list-style-type: none"> <li>Check total load</li> <li>Clean cooling fins on EPD</li> </ul>
<b>Four blinks, pause, four blinks, pause</b>	<b>Input power fault. Low voltage condition in power to EPD.</b>	<b>Unplug battery power from EPD to reset. Check power cables and connections for quality. Be certain that power cable connects directly to battery and has a solid, clean connection.</b>
Five blinks, pause	Input frequency out of range.	Check PWM Settings on Rate Controller.
<b>Control Signal LEDs</b>		
<b>Light intensity varies</b>	<b>Off - No PWM Signal 100% brightness - Maximum PWM input signal</b>	Typically, this is shown by the Red light in the top right corner of the EPD module. The red light should light up when the module is receiving a PWM signal from the controller.

**The most common issue with the EPD will be a low voltage condition (under load) delivered to the EPD from the battery. Voltage drop occurs anytime current is moved through a wire. A low-voltage (12 v) system with long runs (60-80 feet) may have unacceptable voltage drops if any part of the system is weak or the load is high. This could be bad (corroded, weak, loose or burnt) connectors (at the battery, at the hitch, and at the EPD), too small of wire used (smaller wire equals more voltage drop), low source voltage, and heavy load. Any or all of these may contribute to a low voltage condition under load that may shut down the processor in the EPD module. This will be indicated by 4 quick flashes of the red light, followed by a short pause. Unplug the Power-In connector to reset the EPD.**

## Troubleshooting / Service Tips

**Always verify the controller settings. See the screenshots in Section F of the system manual and on the QuickStart setup sheet.**

# G

Troubleshooting

### The pump won't run.

#### Electric Pump System

##### EPD flashing 4 times

1. Find the EPD module (electric pump driver—black module on Tower). Should have a steady blinking light (one blink per second) in the middle when pumps should be off. (The blinking light will go off after 5 minutes of inactivity.) In Run mode, the center light should be steady red, the upper right should be steady red (indicates it is receiving a PWM signal). If Status LED (center light) is *flashing 4 times, then pausing*, EPD has tripped due to low voltage condition. Unplug the Power Supply to the EPD to reset. If condition persists, check Power Supply cables from battery to EPD to insure solid connections and good electrical path. Check connections at battery. Check connectors at the hitch and at the EPD. (*There should be 11.5-13 volts at the point where the EPD connects to the battery power harness, when tested under load. This voltage may show up when there is no load, but the harnessing may not be good enough to deliver 11.5-13 volts under load.*)

##### No Lights on EPD

1. There should be a steady blinking light in the middle of the EPD. If no light is ON, check the 40-amp fuse in the EPD harness near the battery. Use a voltmeter to verify that there is 12-13 volts at the Power Supply connector that plugs into the EPD. *If there is good voltage here, but no light on the EPD, replace the EPD module.*

##### Will pumps run?

1. Connect the two large connectors that are plugged into the bottom of the EPD to each other (bypass the module and supply 12 volts directly to pumps).
2. Do the pumps run? If not, check the 40 amp fuse in the EPD harness near the tractor battery. Inspect harnesses and connections. If 2 pump system, plug pumps in by themselves to check individually. If pump won't run, connect it to pickup battery with jumper cables.

##### Pumps run, but won't pump anything—

1. Are valves from tank to pump open? Is strainer clean? Close recirculation. Open air bleed valve.
2. Tap on pump with rubber mallet. Pour water (hot, if available) in inlet of pump. Remove outlet hose from pump.

#### Electric pumps only run with 12 volts direct from battery

##### Check to see if a PWM signal is getting to the EPD:

1. Connect pumps and power harness back to EPD.
2. Go to **Manual operation** to investigate this issue.
3. Start a test in manual mode, hold down "+" button for 8-10 seconds. A single tap of this button produces a very small change in signal to the valve, so you must hold it. (*Look at PWM Percent on Diagnostics screen*)
4. Remove PWM valve connector at EPD and check voltage. You will need 6-12 volts to turn pumps on. (PWM Duty Cycle at 100 should be 12+ volts on PWM signal)
5. If 6-12 volts is not present, check harnesses and review control valve type setup (should be PWM).
6. Go back to the 12-pin Deutsch pump connector, check PWM voltage between Pins 5 & 6.
7. If necessary, go back to the 8-pin Channel connector on the LPCM. There should be PWM voltage between pins 2 and 7.

##### Pump runs for a while when I push the (+) button on switch box, then stops.

Verify that controller is set to PWM and not to Servo.

# Section Valve(s) will not move



1. Go to **Manual operation mode** to investigate this issue.
2. Start a Manual test. Turn each section switch on and off. Verify the valves operate correctly.
3. If none of the valves are working, or if half of the valves are working, it may be a Power (or Ground) issue. The odd-numbered sections have one power source, the even-numbered sections have another power source. (See harness diagrams) Be sure the 2-pin Deutsch power connector is plugged in to the Adapter Harness by the LPCM.

Pin	Function
A	+ 12 V Constant
B	Ground
C	+ 12 V Signal

4. If a valve does not open, switch the connector that is plugged into that valve with a connector that is plugged into a working valve. Also, plug in the connector to the non-working valve to a valve that is working.
5. Check the harness connection to the non-working valve. It is a 3-Pin Weather Pack connector. Check voltage pin A to Pin B. Must be 12 volts, if not, go back to the next harness connection and check the voltage there. (See harness diagrams for pins)
6. If voltage is present on pins A&B of 3 pin connection to valve, then check Pin C to Pin B. This should be 12 volts when the valve is commanded on or open. This should be zero volts when valve is off or closed.
7. If signal voltage is not present to open valve, use diagrams to check at the 14-pin connector, then the 30-pin on the Field-IQ module for voltage on the proper pin for that section.
8. If harnesses and voltages are good, but valve still will not open, remove the actuator from the valve and see if the actuator will work when it is not connected to the valve. Use a wrench to turn the valve to be sure it is moving freely. Be sure actuator and valve are oriented correctly when you put them back together.
9. If constant voltage (Pins A&B) and switched voltage (Pins C&B) are present, inspect, repair or replace the valve.



**This is a 3-way valve.** If product will not flow when valve is ON, either move the outlet hose to the other outlet port, or remove actuator and rotate valve ball 180°, and replace actuator. Product should flow through the port closest to the Indicator light when the valve is open (green).

## Pressure Sensor is not reading

1. Be sure the Pressure Sensor that is displayed on your screen is the same sensor that is plugged into your harness for that product.
2. Make sure the pins where the harness screws on to the end of the sensor have not been bent.
3. Be sure Pressure Sensor is set up and calibrated in the display. Unplug the pressure harness before doing this.

The calibration is **50 mv/PSI**.

4. There should be a green LED light on the end of the pressure sensor. (may be difficult to see in daylight). The sensor needs 12 v. Check between pins B&C on the Pressure connector on the harness that connects to the pressure sensor. If there is no voltage here, check the voltage between pins 1 & 2 on the 12-pin connector labeled PUMP.
5. **Testing Pressure Sensor Harnessing:** If the pressure sensor is not reading, you can use a AA or AAA battery to test the harnessing. Connect the (-) end of the battery to pin C and the (+) end to pin A of the pressure connector. The 1.5 v should show up as 30 psi on the screen. You can check this at *Diagnostics > Sensors*.

# Application Rate & Flow Troubleshooting

# G

Troubleshooting

## Application Rate Fluctuates

First, you need to determine if the fluctuation is caused by the controller sending fluctuating signals to the valve.

1. **Inspect & clean pump inlet strainer.** Strange flow rate fluctuations are very often due to an obstruction to the pump inlet. Inspect plumbing from tank to pump.

OR

1. Go to Rate Control Detail Screen as shown in Initial Operation, Section F.
2. Turn the system on and watch the flow in GPM.
3. Is the flow steady within a very small range? For example a fluctuation from 2.3 to 2.5 GPM would be considered normal. A fluctuation from 2-3 GPM is a problem. If only a small normal fluctuation is seen, skip steps 4-8 and proceed to "Application Rate Fluctuates in Field ..... " below.
4. If there is a large fluctuation, observe the system flow. Is the discharge a steady stream? Are the flow indicator balls floating steady?
5. If visually the flow is steady, but the display reports a fluctuation in GPM, inspect the flowmeter. See section B for flowmeter information.
6. If visually the flow is unsteady, the flowmeter is working correctly reporting a flow problem. Is the pump turning steady or surging?
7. Look for any type of obstruction in the pump inlet. Clean the strainer. If continually plugging the strainer, investigate fertilizer quality and necessary strainer size.

## Application Rate fluctuates in field, but flow in manual mode is stable.

This problem indicates the PWM gain needs changed. The system is surging because the Liquid Product Control Module is moving the pump driver too much.

1. Go to Controller Settings.
2. Change the settings by reducing the PWM gain (start with increments of 500).

## Application Rate is slow to get to the Target Rate

1. You may need to increase the valve calibration. Go to Controller Settings.
2. Change the settings by increasing the PWM gain. SurePoint recommends a PWM gain of 9900 for electric pump systems. Increase if necessary for quicker adjustment.
3. If the system is slow to get to Target Rate when starting, increase the Zero Flow Offset (see pages 47 and 57).

## No Flow shown on Ag Leader display but liquid is being pumped

1. Unplug flowmeter. With voltmeter, check for 12 volts between pins B&C on 3-pin MP (or pins 1 & 2 on AMP SuperSeal) flowmeter connector. If 12 volts not present, inspect wiring harness and troubleshoot all connections per schematic (see Section D).
2. If 12 volts is present, then conduct a tap test. Go to setup and change the flow cal to 10. Have a second person watch GPM on the Rate Control Detail screen while other person taps (use a short piece of wire or a paper clip) between pins A&C on 3-pin MP connector (or between pins 1 & 3 on the AMP SuperSeal connector). A flow value should show up indicating the wiring is not damaged.
3. If the display responded to the tap test, your wiring to that point is good. If still not fixed, inspect adapter harness and test continuity per schematic (see Section D).
4. Replace flowmeter.

# No Flow shown on display, but liquid is being pumped

## Flowmeter Tap Test



See which flowmeter connector you have

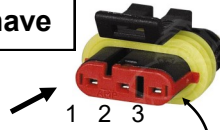

Remove red guard to reach pins. Don't break red side clips.

Flowmeter pinout:

**3-pin MP Tower**      **A- Signal   B- 12V Power   C- Ground**  
**3-pin AMP SuperSeal**      **1- Ground   2- 12V Power   3- Signal**

1. Unplug the flowmeter. With voltmeter, check for **12 volts between Power & Ground** of flowmeter connector. Should have **4-5 volts between signal and ground**. If voltage is not present, inspect wiring harness and check for voltage at harness connection(s) nearer the Rate Controller (at 12-pin Deutsch connector, Power is 1, Ground is 2, Flow Signal is 3).
2. If 12 volts is present, then conduct a **tap test**. Go to **Setup** and change the flow cal to 1. Have a second person watch GPM on the screen while other person taps repeatedly (use a short piece of wire or a paper clip) between signal and ground pins of flowmeter connector. A flow value (gpm) should show up indicating the wiring is not damaged. (If alone, note or reset a volume counter to 0. Check for increased volume after tapping.)
3. If the flow showed on the display during the tap test, your wiring to that point is good. If tap test did not work, go back to the next harness connection and do a tap test there between signal and ground.
4. If the tap test registers flow on the display, replace flowmeter. (*Sometimes, cleaning the inside tube of the flowmeter with soapy water and a soft brush will remove a film covering the electrodes.*)
5. Change Flow Cal back to appropriate Flow Cal when finished with Tap Test.
6. SurePoint has a Speed/Flow Simulator (PN 219-01462) or a Tap Tester (212-03-3912Y1) that can be used to confirm if the wiring is good between the flowmeter and controller.

### Field Verification of Flowmeter Calibration

*Always verify the flow cal setting by comparing the amount actually applied in the field (from weigh tickets) with the amount shown on the display. Adjust the flow cal as needed to get less than 1% difference between the actual amount applied and the amount shown on the display.*

**In general:**

**Increase the Flow Cal number if not enough product is actually being applied.** (If you want more, increase the number)

**Decrease the Flow Cal number if too much product is being applied.** (If you want less, decrease the number)

#### Formula to Adjust Flow Cal Number

**$(\text{Volume shown on display}) / (\text{Volume actually applied}) \times \text{flow cal number in display} = \text{new flow cal}$**

Example: Display shows 727 gallons was applied. Weigh ticket shows 750 gallons was actually applied. Flow cal number in display was 3000. (*We applied too much, so we will decrease the flow cal.*)

$$727 / 750 \times 3000 = 2908 \text{ (new flow cal number to set in display)}$$

*(Any adjustments to the flow cal number will only be as accurate as the measurements used in figuring it.)*

Do not power wash the flowmeter.

Unplug the flowmeter before welding on the implement.

# Liquid Diagnostics Screen - Device Information



## Diagnostics - Device Information

**Devices**

CAN A    CAN B

DISPLAY	Firmware: 1.19.0
232 Liquid Product Module	Firmware ID: DC LIQUID
233 Auxiliary Input Module	Hardware ID: 4000405
<b>128 Liquid Product Module</b>	Product ID: DC LIQUID
	Serial Number: 2012751094
	Revision: 4.2.0.0
	Run Time: 1035976:05:07
	Boot Counter: 396
	CAN Name: A00C81010C21D906

**Diagnostics**

**Liquid Diagnostics**

Controller Name	DirectLiquid
Serial Number	2012751094
Main Pressure (kPa)	0
Agitation Pressure (kPa)	N/A
Auxiliary Pressure (kPa)	0
PWM Duty Cycle (%)	0
<b>Flow Meter Signal Frequency (Hz)</b>	<b>2</b>
<b>Flow Meter Pulse Count</b>	<b>34</b>

During Flowmeter Tap Test a small number should register on the Flow Meter Signal Frequency and the Flow Meter Pulse Count should increase.

# Recommended Care and Maintenance



Maintenance  
& Parts

## Winterization

SurePoint recommends flushing your fertilizer pump and complete system with adequate amounts of water first. Next, use RV antifreeze to winterize your system by pumping an adequate amount through all components. At the beginning of the next season, begin with water to verify the system is in working order with no leaks.

If equipment will be left outdoors, consider covering flow indicator tubes to reduce UV fogging.

## Inspect Electric Pumps

The electric pump and motor is a completely sealed component. Over time the electric motor will lose efficiency. The entire pump and motor will need replaced when it won't efficiently produce the flow required.

Each individual pump should be able to produce more than 4 gpm of water flow with an open outlet (zero pressure). If pump falls short of this specification, replace to ensure a trouble free fertilizing operation.

Test each pump individually to verify that each pump is working efficiently.

## Pre-season Service for Electric Pump Systems

*(A little time spent here may prevent some downtime when you want to be rolling.)*



1. Visually check entire system (hoses, fittings, harnesses, etc.) for any signs of wear or trouble. If connectors, harnesses, or parts have been soaked in fertilizer, check these very carefully.
2. Particularly check all 37- and 16-pin connectors on systems that have been in use. Be sure pins are clean, not corroded, and are making good contact. Corroded pins need to be replaced. Cleaning will not restore good electrical contact. If the pin has corroded, a lot of time the corrosion extends to the first part of the wire. If there is much corrosion, consider replacing the cable. Newer style cables have Deutsch connectors that seal better than the round AMP connectors.
3. Check all power cables / connectors beginning at the battery. Verify voltage at LPCM and to SurePoint Adapter harness (3768).
4. Check the flow indicators for cracks and clarity. They can become weathered and difficult to see through.
5. Test each pump by itself to verify that both pumps are working as they should. If the pump runs, but won't pump, tap it with a rubber mallet or pour hot water into the pump inlet. To prime the pump, be sure the recirculation knob is closed and the air bleed valve is open.
6. On the display, recheck all setup screens (see Section F of the manual) to verify correct setup.
7. Raise and lower the implement to verify that the height switch (if being used) arrow is indicating correctly on the Run Screen by the Master Switch indicator.
8. Fill system with water and run in Manual mode to verify components and system are in working order. (May need to open air bleed valve to prime pump the first time. Be sure the air bleed valve and tube are not plugged. Be sure recirculation knob is closed.) In these two tests, you should be able to speed the pump up and slow it down with the (+) and (-) button. SurePoint gives recommendations for setting the PWM Low Limit (Zero Flow Offset) that generally work for nearly all systems. It is possible to fine-tune those settings. The Zero Flow Offset should be a setting at which the pump will run enough to register steady flow on the flowmeter. If the pump will be operating at a higher level (even when running with only one section on) the Zero Flow Offset can be increased. This is particularly helpful to get quicker startup at the beginning of a pass. Understand that the pump will not slow down below the Zero Flow Offset so if it is too high, there could be over-application at those times that lower output is needed (such as with only one section on). Some operators may be willing to live with a little over-application on the small areas that will be covered with only one section on to get a faster startup on every pass by setting the Zero Flow Offset higher.
  - a. This is a good time to check out the Device Button > Diagnostics screen. This is a screen that every tech and every user should regularly check.
  - b. On the Liquid Diagnostics screen, check out the flowmeter operation at Flowmeter (Hz) to see the pulses (per second) that are being generated by the flowmeter. With the pump running at a steady speed this should be stable ( $\pm 2$  Hz variation).
  - c. Check out the PWM Duty Cycle. On an Auto Test or while operating in the field at a steady speed, this should also be steady ( $\pm 2$ ). If this is bouncing around more, lower the PWM Gain. 9900 is our starting point on the PWM Gain for an electric pump.

9. Tighten all clamps. Loose clamps may be evident by leaks on the output side of the system. Loose clamps from the tank to the pump are not always apparent but can be sources of air getting into the system which can create issues.
10. Push in all QuickConnect (QC) fittings to be sure the tubes are tightly seated. Unseated QC fittings may not leak but they can cause check valves to leak because they allow air to be drawn into the system when application stops.
11. Remove the blue or black cap from the top of each check valve. Check the diaphragm to be sure it is intact and not gummed up with residue. Look under the diaphragm for debris. Compress the spring in the cap to be sure it moves freely. Carefully replace diaphragm and tighten cap. These check valve fairprene diaphragms (133-03-40155-07) and the O-ring (133-03-40160) in the check valve should be replaced every year or two for best performance.
12. Remove and clean the strainer. Be sure strainer is tightened securely so it will not suck air. Check the housing for cracks.
13. Run system with a simulated speed and rate to be used in the field.
14. Be sure all rows are flowing and that all metering tubes/orifices are open. (Note: It will take a higher flow rate with water to create enough pressure to open all the check valves so that each row will flow.)
15. While the test is running, go to Device Button > Diagnostics > Liquid Diagnostics screen and look at Pressure, Flow and PWM Duty Cycle).
16. Verify that all sections open and close (and in the correct order) with the switches in a Manual test.
17. Check the placement devices for wear and alignment. Check tension on Keeton seed farmers. Use Flow Simulator (219-01462) or Tap Tester tool (212-03-3912Y1) to verify harnessing. Use Pressure Simulator (212-03-3910Y1) to verify harnessing and setup and to change LiquiShift valves.

Techs and end users should be familiar with the SurePoint Ag website where manuals and documentation are available for download.

<http://www.surepointag.com/support>