

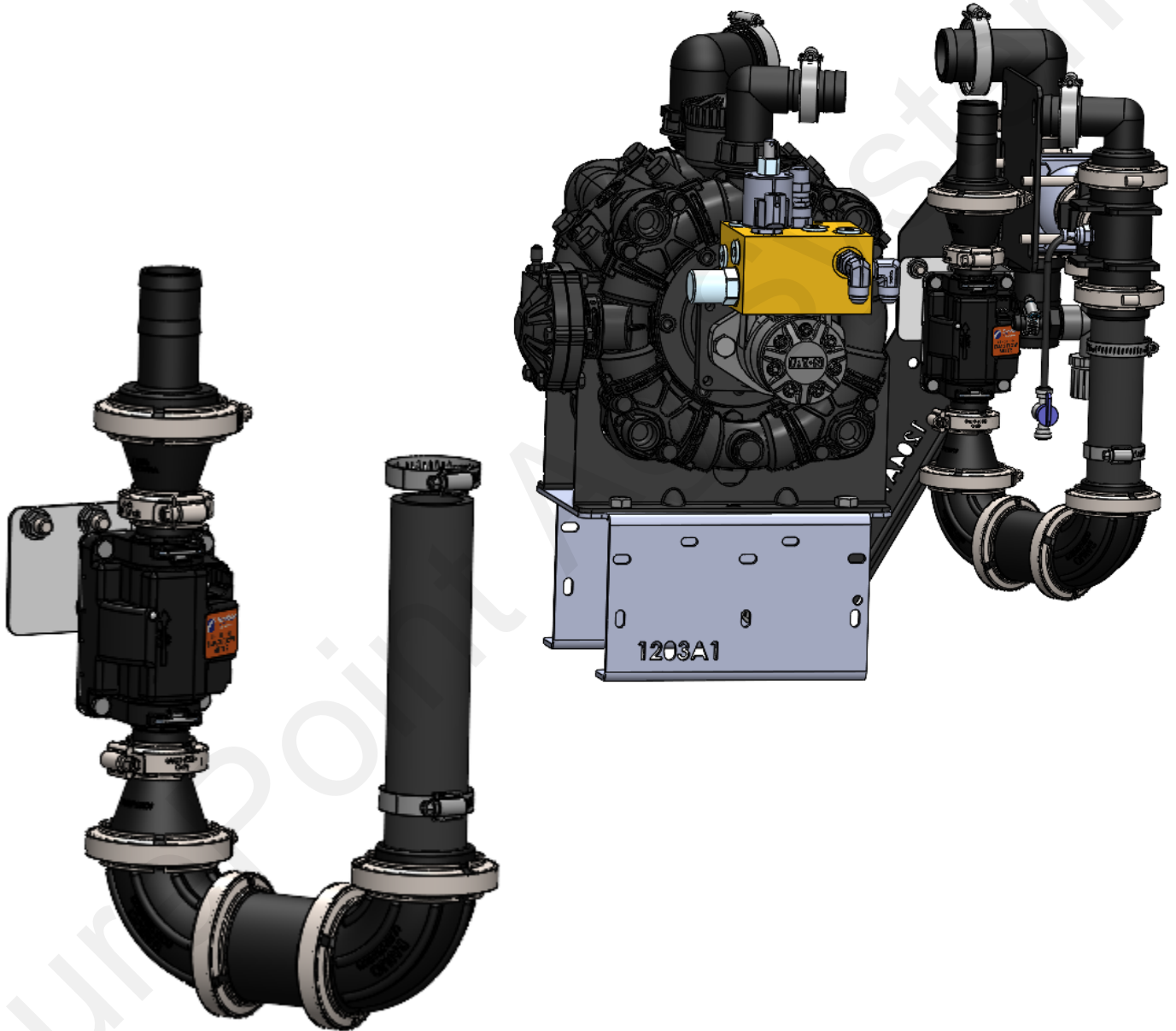

396-7210Y1

PR40/D250 Pump, Orion 3 DN17 Flowmeter Retrofit Kit Instructions



Kit Number:

500-02-2404 : Retrofit Kit, PR40/D250 Orion 3 DN17, 1.45 - 58 GPM



Parts List and Exploded View

ITEM #	Part Number	Description	QTY
1	204-01-462034A-DN17	EMag Flowmeter, Orion 3, 1.45 - 58 GPM, M100 Flange	1
2	105-220100CPG	2" Full Port X 1" Reducer Flange	2
3	105-220150BRB	2" Full Port Manifold x 1 1/2" HB	2
4	400-7136Y1-BK	PR40/D250 ORION 3 DN17 Flowmeter Adapter Bracket Retrofit	1
5	300-040100-SS	BOLT, HEX HEAD, 1/4-20 x 1, STAINLESS STEEL	4
6	323-04-SS	NUT, SERRATED FLANGE, 1/4-20, STAINLESS STEEL	4
7	300-060100-SS	BOLT, HEX HEAD, 3/8-16 x 1, STAINLESS STEEL	3
8	323-06-SS	NUT, SERRATED FLANGE, 3/8-16, STAINLESS STEEL	3
9	105-100G-H	1" EPDM Manifold Gasket	2
10	105-FC100	1" Manifold Clamp	2
11	105-FC220	2" Full Port Manifold Clamp	5
12	105-200G-H	2" Full Port EPDM Gasket	5
13	105-220SWP90	2" Full Port 90° Sweep	2
14	105-220CPG	2" X 2" Full Port Flange X 2 31/32" Long	1
15	350-2808	SS Hose Clamp - Size 28 - 2-1/4" Diameter	2
16	280-150-3000S 8.5"L	1 1/2" 3000 Series Bulk 8.5"L	1

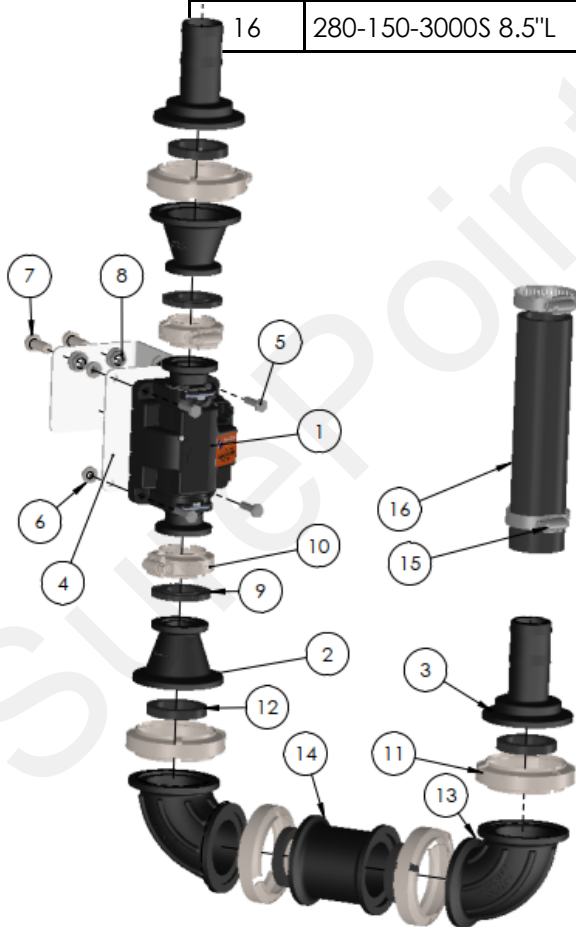



Parts List and Exploded View

ITEM #	Part Number	Description	QTY
1	204-01-462034	EMag Flowmeter, Orion 3, 1.45 - 58 GPM, T3F	1
2	120-M100T3M	M100 to T3M for DN17 Meter	2
3	124-01-G11058-V	Viton O-Ring for T3 fittings	2
4	124-02-010003	T3 fork	2
5	398-20-6856Y1	DECAL, EMAG (ORION3) FLOWMETER 1.5 - 58 GPM	1



Step by Step Instructions Old Flowmeter Removal

1. Disconnect harness from flowmeter electrical connection point.
2. Detach hose from flowmeter outlet. Hose and hose-clamp will be reused if possible.
3. Loosen hose clamps on both ends of hose on Flowmeter inlet. Remove and discard hose.
4. Remove 4x 5/16" hex bolts holding flowmeter bracket to pump bracket.
5. Remove and discard flowmeter/brackets assembly.

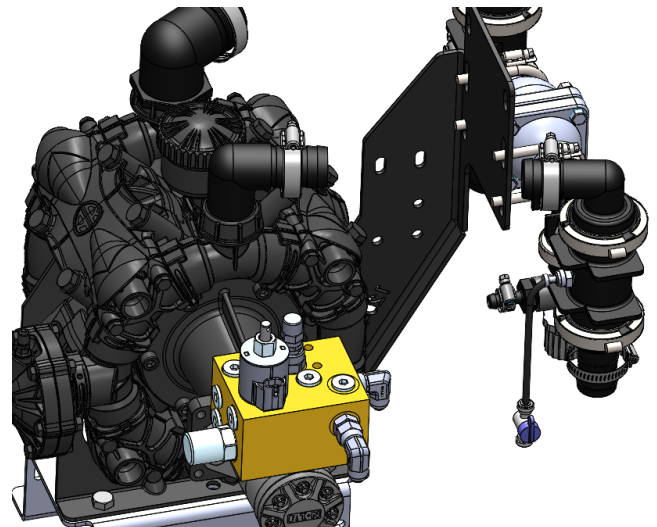
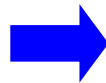
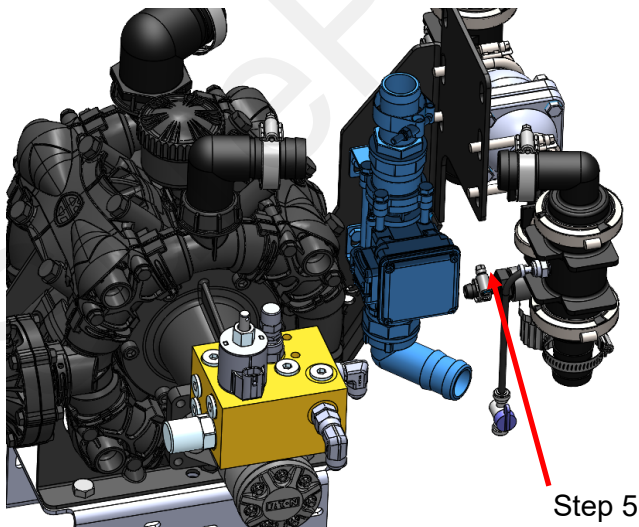
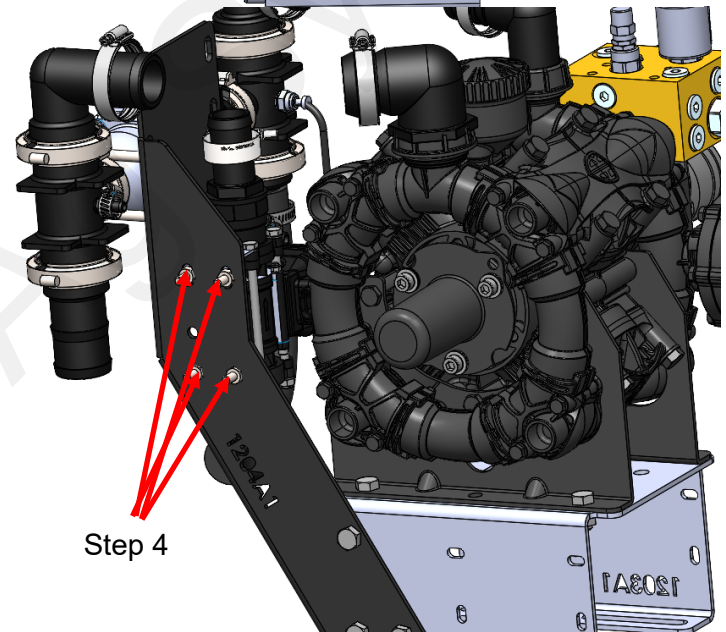
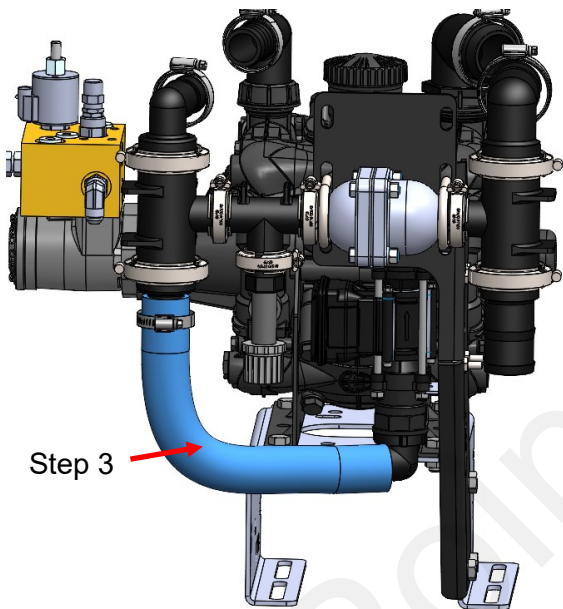
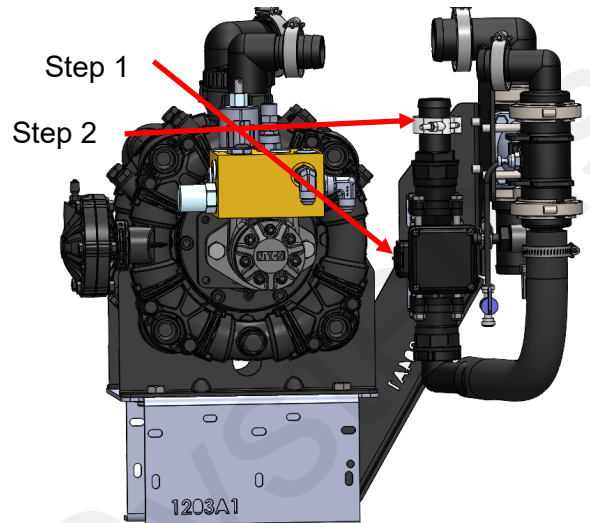



Step by Step Instructions Pre-Assembly– Flowmeter/Bracket

1. Attached new flowmeter assembly [204-01-462034A-DN17] to new bracket [400-7136Y1-BK], using four bolts [300-040108-SS — 1/4" x 1-1/2" Hex Head Bolt - SS] and nuts [323-04-SS — 1/4" Flange Nut - SS].
Ensure Flowmeter flow direction arrow is pointing up.
2. Attach plumbing fittings to outlet of flowmeter. [105-220100CPG] M100 x M220 reducer coupling, and [105-220150BRB] M220 Flange x 1-1/2" Hose Barb. Using gaskets [105-100G-H] & [105-200G-H], and flange clamps [105-FC100] & [105-FC220]
3. Attach plumbing fittings to inlet of the flowmeter using M100 and M220 Clamps and Gaskets. Fitting order from flowmeter to hose barb is: [105-220100CPG],[105-220SWP90],[105-220CPG],[105-220SWP90],[105-220105BRB].
4. NOTE: Leave one of the two clamps near green arrow slightly loose to allow for some rotation in future step.
5. Full flowmeter and bracket assembly is ready to assemble on to existing pump.

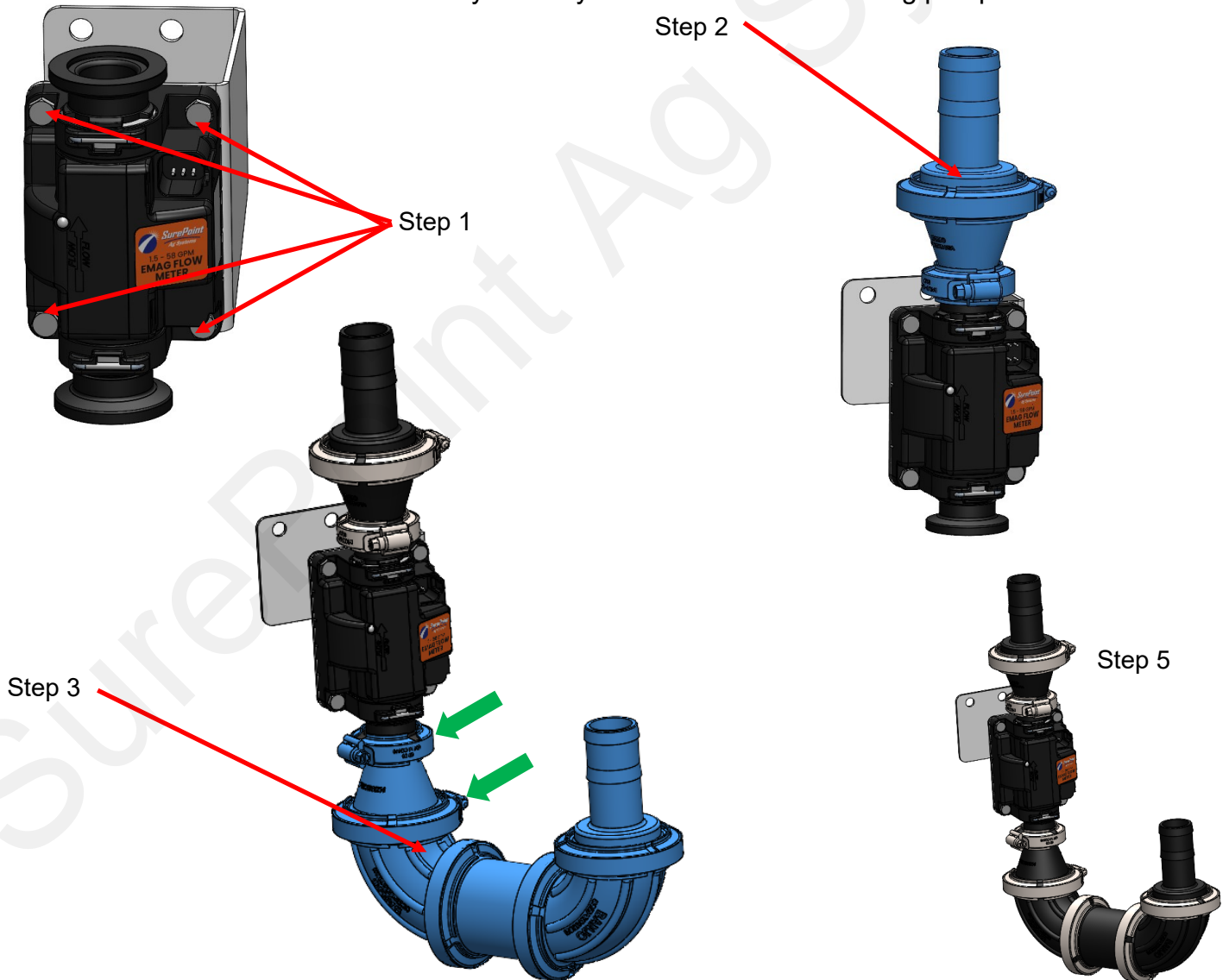

Step by Step Instructions

Assembly– Flowmeter/Bracket to Pump

1. Attach the new flowmeter/bracket pre-assembly to pump bracket arm, using 3 bolts [300-060100-SS — 3/8" x 1" Hex Head Bolt - SS] and nuts [323-06-SS — 3/8" Flange Nut - SS]. Tighten bolts only hand tight til a later step.
2. Rotate the flowmeter inlet plumbing assembly using the semi-loosened clamp from the previous page to align the two indicated hose barbs. Firmly tighten flange clamp to secure the aligned angle.
3. Remove flowmeter assembly and install 1-1/2" hose to flowmeter inlet hose barb and clamp in place with hose clamp.
4. Note: Kit is supplied with 8.5" Hose piece which should be about the length needed for a D250 pump. Cut supplied hose piece to about 6" length for a PR40 Pum. Verify length required in each install situation.

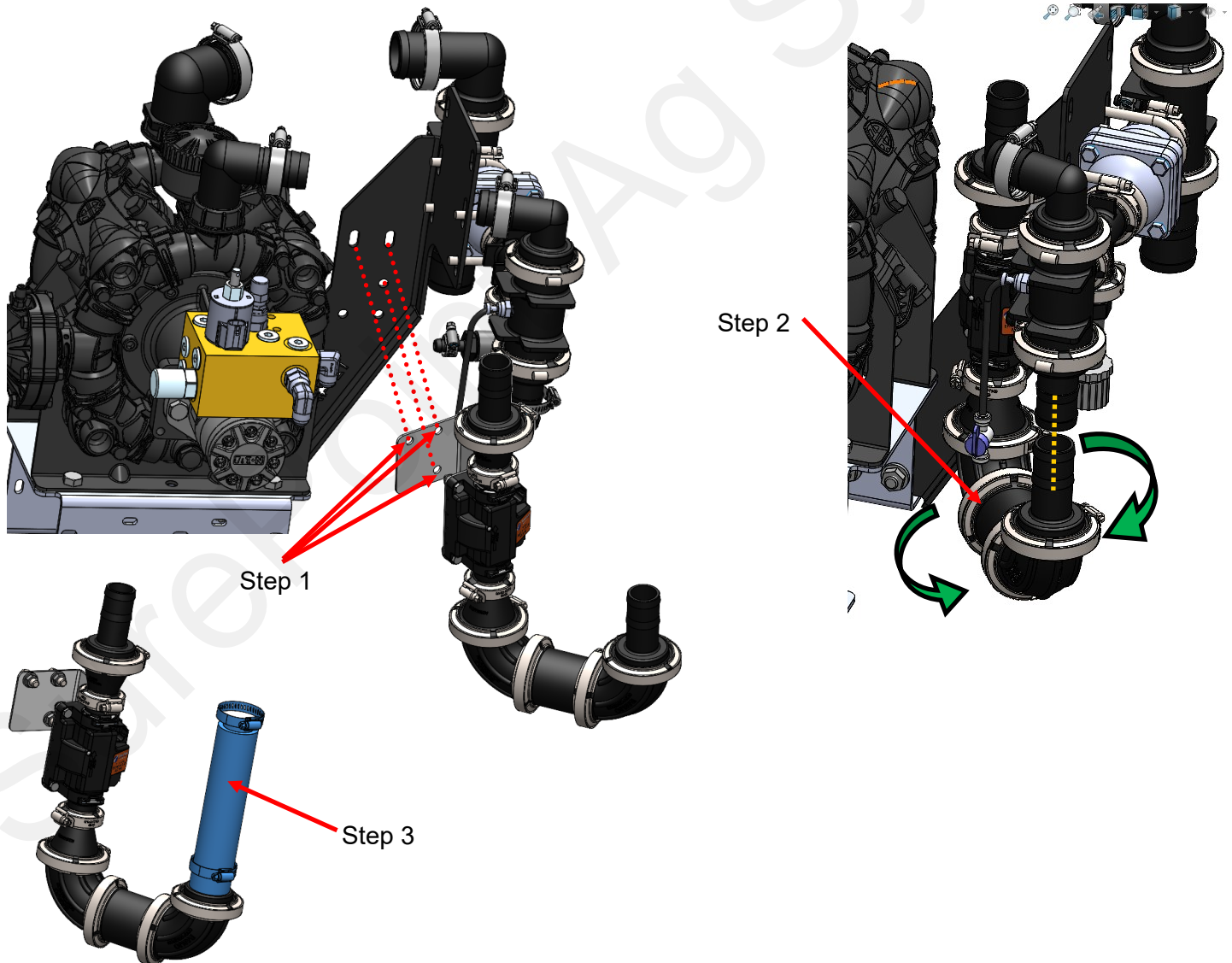



Step by Step Instructions Assembly– Flowmeter/Bracket to Pump (Continued)

5. Attach other end of hose to existing 1-1/2" hose barb while re-attaching flowmeter bracket to pump arm bracket using 3 bolts. Tightened hose clamps and bracket bolts.
6. Reattach hose from distribution system to Flowmeter outlet hose barb.
7. Using supplied harness adapter connect "flowmeter-labeled" harness lead to 6-pin connection point on new flowmeter.
8. Update flowmeter calibration number in controller settings (see next page).

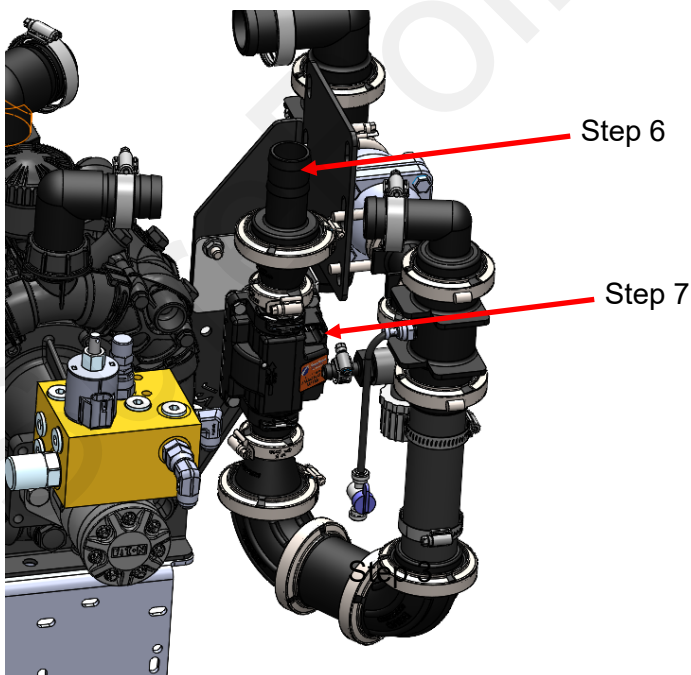
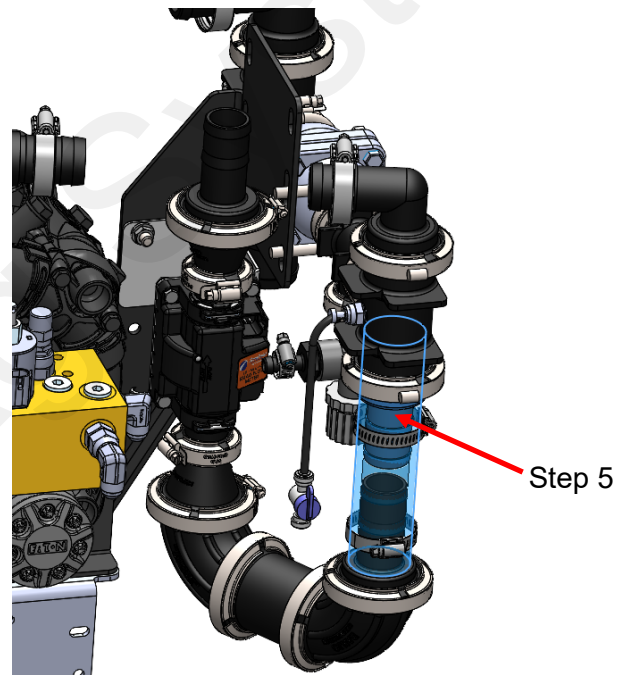
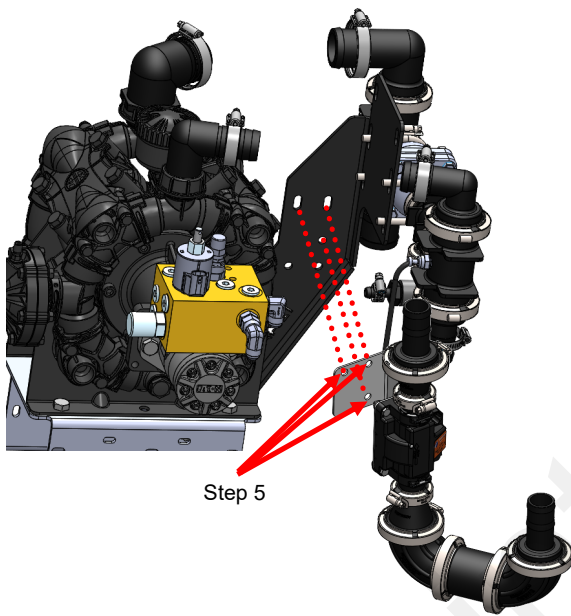

PR40 & D250 Electromagnetic Flowmeter Update Part Info Sheet



EMag Flowmeter, Orion 3, 1.45 - 58 GPM, M100 Flange P/N 204-01-462034A-DN17

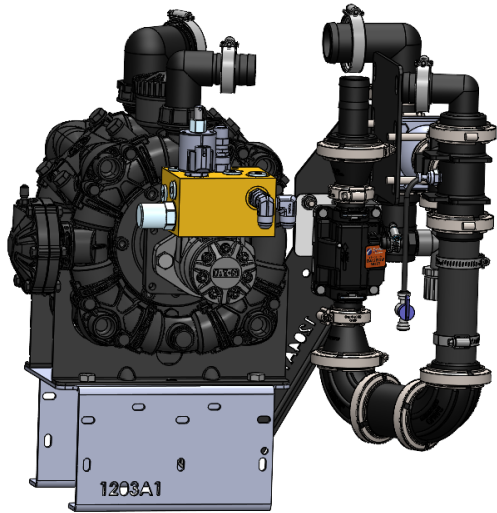

6-Pin Deutsch connector
 Use adapter 201-5954Y1 to connect to 3-pin AMP Superseal harness.
 OR Alternate adapter 201-6647Y1 to connect to 3-pin MP Shroud

Controller- Flow Cals are listed in Pulses per Gallon unless noted	DN17 1.45-58 GPM Flow Cal Number	DN107 1.45-58 GPM Flow Cal Number with Divide by 8 Cable
Sentinel	2063	258
Commander	4126	516
Commander II	4126	516
John Deere	2063	258
Ag Leader	2063	258
Trimble	2063	258
Raven	2063	258
Topcon	2063	258
Case (ECU) Pulses per 10 Liters	Requires Divide by 8 Cable	681
Case (UCM) Pulses per Liter	545	68

Orion 3 Flowmeter will need to adapt from the 6-Pin Deutsch to the flowmeter plug on the harness. These adapters are listed on page 2.

The "Divide by 8" adapter harness must be used in applications where the controller will not accept the required flow cal number. The "Divide by 8" adapters listed on the next page could be on your system and will need to use the above flow cal number associated with your controller.

PR40 & D250 Electromagnetic Flowmeter Update Part Info Sheet



EMag Flowmeter, Orion 3, 1.45 - 58 GPM, M100 Flange P/N 204-01-462034A-DN17

Adapter Part Number	Description	Uses
201-5954Y1	3-Pin AMP Superseal Shroud to 6-Pin Deutsch Tower	Pump final cable to Orion 3 Flowmeter
201-6647Y1	3-Pin MP Shroud to 6-Pin Deutsch Tower	Pump final cable to Orion 3 Flowmeter used on Commander II and E-Mag Flowmeter with Blue Sticker and White Lettering.
Divide by 8 Adapters	The "Divide by 8" adapter harness must be used in applications where the controller will not accept the required flow cal number.	Could be on your existing system and will need to use correct flow cal from chart on previous page.
201-14226	3-Pin MP Shroud to 3-Pin MP Tower with divide by 8	Multiple Controllers
201-17842	3-Pin MP Shroud to 3-Pin AMP Superseal Tower with divide by 8	Multiple Controllers
201-19849	3-Pin AMP Superseal Shroud to 3-Pin AMP Superseal Tower with divide by 8	Used commonly with Case Planter with ECU

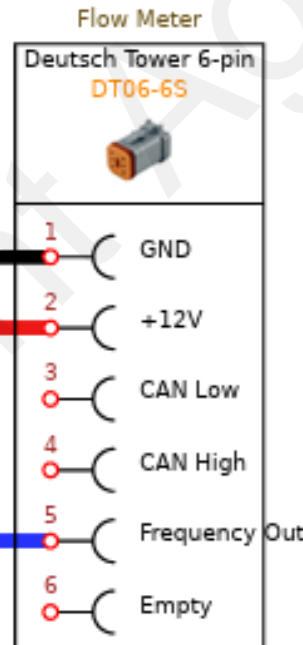
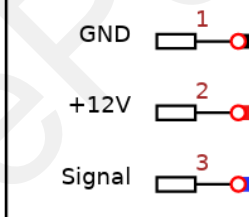
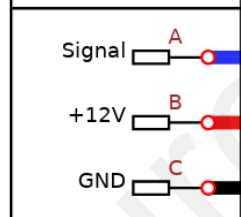

Adapter Harness Connections Shown to the Left.

201-14226 -Shown with divide by 8 module circled.



SurePoint recommends you perform a catch test to verify the system is properly installed and configured. Adjust the flow cal as needed based on accurate catch tests with the actual product or

Warning!!!

-Before doing any welding on the implement, unplug the cable to the flowmeter, or damage to the flowmeter may result.

-Do not power wash the flowmeter. High pressure spray directed at the back edge of the face plate or at the wire connector may allow water into the flowmeter electronics.