



396-6636Y1

Liquid Application Systems Item Return Process

Step 1: Obtain RMA Number from SurePoint Ag

To inquire about return policies and procedures, contact the SurePoint Ag Systems sales department during our business hours: (8 AM - 5 PM: M - F)

- Call Toll Free at +1 (866) 626-3670
- Text at +1 (785) 626-8561

A Return Merchandise Authorization (RMA) number must be obtained prior to returning any equipment to SurePoint Ag Systems for any reason.

To obtain an RMA number, contact your SurePoint Ag Systems sales representative. Reference the phone numbers listed above.

- No product returns will be accepted without an RMA number.
- Each returned individual Liquid Application product must be issued a separate RMA number. A complete Pump system can be returned with a single RMA number.

Step 2: Cleaning and Decontamination



All equipment being returned to SurePoint Ag Systems must be thoroughly cleaned and decontaminated of all foreign substances, including all substances used for cleaning the equipment, prior to shipping. This requirement applies to all pumps, flowmeters, plumbing components, and hydraulic components that could have been exposed to any chemical product or cleaning substances.

Shipments that have not been thoroughly decontaminated may cause a violation of U.S. Department of Transportation (DOT) regulations. For your reference, the requirements for packaging and labeling hazardous substances are listed in DOT regulations 49 CFR 172, 178, and 179.

If you suspect that the Liquid Application product may be contaminated, the product must be completely drained and rinsed to remove any and all contaminants.



Contents of the Liquid Application product may be under pressure. Contents of the Liquid Application product may be hazardous. Take appropriate measures to avoid the hazards associated with gaining access to a contaminated product. Avoid exposure to hazardous materials.

To properly clean and decontaminate your Liquid Application product, you must run water or cleaning substance through every component mentioned above. We recommend connecting the outlet of your Liquid Application product to an empty tote or container, clearly labeled as *Reclaimed Hazardous Material*, so the hazardous rinsate can be contained and properly disposed of.



396-6636Y1

Liquid Application Systems Item Return Process

Step 2: Cleaning and Decontamination Continued

SurePoint Ag Systems recommends rinsing all plumbing components, hoses, valves, pumps, and flowmeters to thoroughly clean and decontaminate your Liquid Application product. Read the suggested steps below to rinse your Liquid Application Product(s): (reference page 4 for pictures)

- Attach a garden hose to the inlet of your Liquid Application system to supply the system with water. If applicable, close the bulk tank valve to ensure no fertilizer or chemical product can be recirculated through the system.
- To ensure that all rinsate is collected, attach the system outlet(s) to a clearly marked *Reclaimed Hazardous Material* container.
- Open all valves in the system to ensure that the system can be fully evacuated. This can include automatic section valves, manual valves, check valves, and Row Control valves.
- If your pump is still operational, enter your cab to operate the pump using the implement display to clear the system of contaminants (reference your product manual for specific instructions on how to operate your system). If your pump is no longer operational, you may need to manually operate the pump to recirculate water through the system.
- If any other item is being returned (**Flowmeter, Valve, Sentinel Flowmeter, etc.**), follow steps above to ensure the component is fully rinsed before shipping.
- All PumpRight hydraulic diaphragm pumps will need to be returned without hydraulics, brackets, flowmeters, and hoses for service.
- Any extra disassembly or cleaning done by SurePoint Ag Systems could be subject to service fees, billed to the customer, upon completion of service.

Decontamination/Cleaning Statement

A blank decontamination/cleaning statement is provided on the final page of this document. You may copy and use this form to return any Liquid Application product.

- A Decontamination/Cleaning Statement is required for each Liquid Application product being returned.
- Each form must be fully completed and include a signature. If the statement is not complete, the customer may be charged for decontamination and cleaning.

Two (2) copies of each Decontamination/Cleaning Statement must be provided:

- One (1) copy must be attached to the outside of the shipping container.
- One (1) copy must be provided inside the container.



396-6636Y1

Liquid Application Systems Item Return Process

Step 3: Material Safety Data Sheets (MSDS)

Included with the returned equipment, you must provide a Material Safety Date Sheet (MSDS) for each substance that has come in contact with the equipment being returned, including substances used for decontamination and cleaning.

An MSDS is required by law to be available to people exposed to specific hazardous substances, with one exception: if the equipment has been exposed only to food-grade substances or potable water, or other substances for which an MSDS is not applicable, the Decontamination/Cleaning Statement form alone is acceptable.

Two (2) copies of each MSDS must be provided:

- One (1) copy must be attached to the outside of the shipping container.
- One (1) copy must be provided inside the container.

Step 4: Packaging

You may return the Liquid Application product in the container it was originally shipped in. If you do not have the original container, you may have to provide your own container to return the product. Please note that damage caused from shipping to SurePoint Ag is the responsibility of the shipper.

Step 5: Shipping

The customer must provide a Packing List and carrier shipping documents for each shipment. The shipping documents contain information necessary for the carrier to ship the freight, such as consignee of shipment, payment terms, number of pieces in shipment, weight, etc. When returning your Liquid Application product, the carrier paperwork needs to include the following address:

SurePoint Ag Systems, Inc.
Attn: (Your Sales Representative)
RMA# _____
9904 KS-25
Atwood, KS 67730

Document Submittal

Place one (1) copy of the packing list inside the container.

Submit (1) copy of the packing list, and one (1) copy of the Bill of Lading to your SurePoint Ag sales representative.

Shipping Charges

The customer is responsible for all shipping charges, ship using prepaid terms.

396-6636Y1

Liquid Application Systems Item Return Process

PumpRight

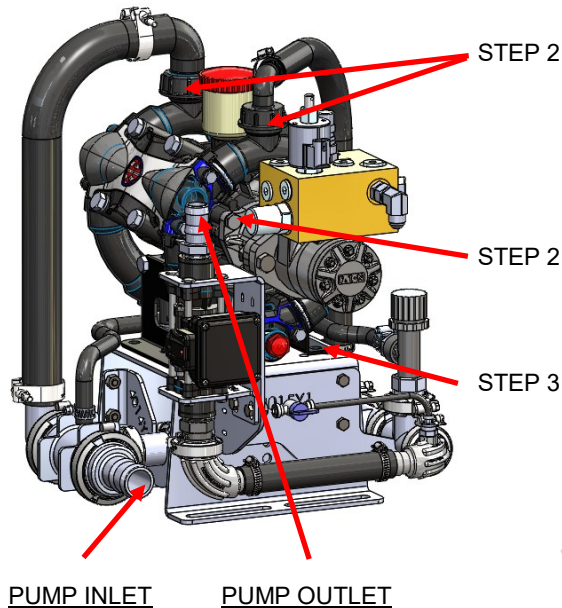

PumpRight Pump Disassembly

1. Rinse all components of your PumpRight by attaching a garden hose to the inlet of the system. Be sure to capture all rinsate in an approved and clearly marked container.
2. Remove plumbing lines from the PumpRight by loosening the through nuts on top of the pump.
3. Remove the two bolts holding the hydraulic motor in place. Remove the hydraulic motor from the pump and secure in a safe location.
4. Remove the bolts and nuts holding the pump to the base plate.
5. Remove the pump from the implement and ensure it is fully rinsed of all fertilizers or cleaning chemicals.

Tower Pump Disassembly

1. Rinse all components of your Tower by attaching a garden hose to the inlet of the system. Be sure to capture all rinsate in an approved and clearly marked container.
2. Remove plumbing lines from the Tower by removing the hoses from the inlet and outlet of the pump. Remove all harnessing from electrical components.
3. Remove the (4) carriage bolts and nuts holding the Tower to the pump mounting bracket.
4. Remove the pump from the implement and ensure it is fully rinsed of all fertilizers or cleaning chemicals.

Tower

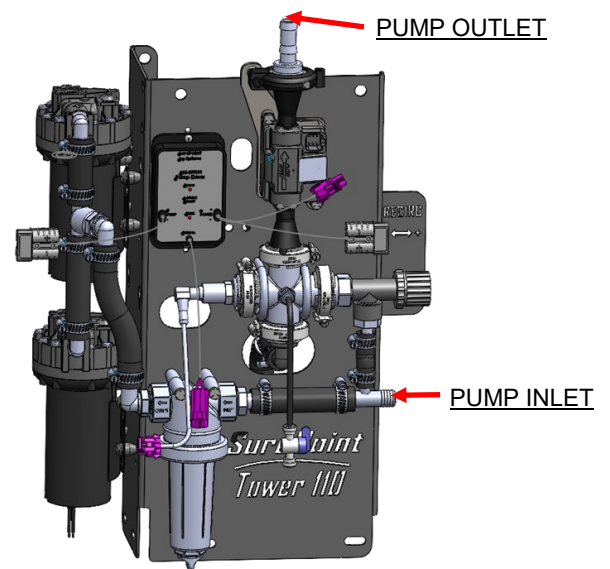



396-6636Y1

Liquid Application Systems Item Return Process

Spartan

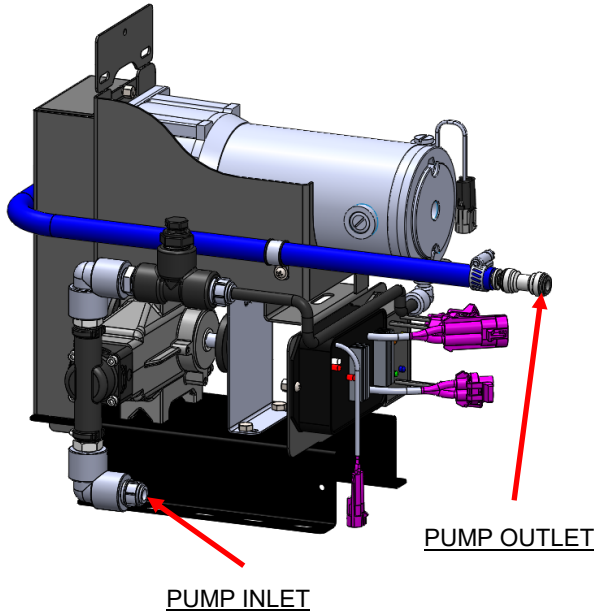

Spartan Pump Disassembly

1. Rinse all components of your Spartan by attaching a garden hose to the inlet of the system. Be sure to capture all rinsate in an approved and clearly marked container.
2. Remove plumbing lines from the Spartan by removing the lines from the inlet and outlet of the pump. Remove all harnessing from electrical components.
3. Remove the (4) bolts and nuts holding the Spartan to the pump mounting bracket.
4. Remove the pump from the implement and ensure it is fully rinsed of all fertilizers or cleaning chemicals.

Decontamination/Cleaning Statement

Refer to SurePoint Ag Systems Return Policy for use with used Liquid Application Products

1. Return Merchandise Authorization (RMA) Number: _____
2. Equipment to be returned Model : _____ Serial Number: _____
3. Reason for return:

Process and Decontamination/Cleaning Fluids			
4. List each substance to which the equipment was exposed. Attach additional documents if necessary			
Common Name	CAS# if available	Used for hazardous waste (40 CFR 261) (Y or N?)	EPA waste code if used for hazardous waste
5. Describe decontamination/cleaning process. Include MSDS description for substances used in decontamination and cleaning processes. Attach additional documents if necessary.			

Shipping Requirements

Failure to comply with this procedure will result in shipment being refused

6. Include inside the container: one copy of this document and all required MSDS
7. Attach to the outside of the package: one copy of this document, and all required MSDS
8. Ship to:
SurePoint Ag Systems
Attn: (Your Sales Representative)
RMA# _____
9904 KS-25
Atwood, KS 67730

EQUIPMENT HAS BEEN CLEANED AND DECONTAMINATED OF ANY HAZARDOUS SUBSTANCES AND MEETS DOT AND EPA REGULATIONS	
By: _____ (Signature)	_____ (Print Name)
Title: _____	Date: _____
Company: _____	
Phone: _____	